

DISTRIBUIDOR AUTORIZADO.

www.imservo.com

ventas1@imservo.com / ventas2@imservo.com

QUITO-GUAYAQUIL

ECUADOR



XINJE

DS3/DS3E/DS3L series servo drive

User manual

WUXI XINJE ELECTRIC CO., LTD.

Serial No. SC3 02 20171010 1.0

All copyrights reserved by WUXI XINJE ELECTRIC CO., LTD.

Any copying, transferring or any other usage is prohibited. Otherwise Xinje will have the right to pursue legal responsibilities. All rights including patent and permission of modules and designs are reserved.

January, 2010

Safety Precautions

Be sure to review this section carefully before use this product. In precondition of security, wire the product correctly.

The following defines the symbols used in this manual to indicate varying degrees of safety precautions and to identify the corresponding level of hazard inherent to each. Failure to follow precautions provided in this manual can result in serious, possibly even fatal, injury, and/or damage to the persons, products, or related equipment and systems.



CAUTION

Indicates a potentially hazardous situation, which, if not heeded, could result in death or serious injury.



WARNING

Indicates a potentially hazardous situation, which, if not avoided, may result in minor or moderate injury.

● Checking Products upon Delivery



CAUTION

1. DO NOT install any drive which is damaged, lack of accessories or not the same with the model ordered.

Doing so may result in electric shock.

● Installation



WARNING

1. Cut off external power supply before installation.

Not doing so may result in electric shock.



CAUTION

1. Always use the servomotor and servo amplifier in one of the specified combinations.

Never use the products in an environment subject to water, corrosive gases, inflammable gases, or combustibles.

Doing so may result in electric shock, fire or malfunction.

2. DO NOT touch any metallic part.

Doing so may result in malfunction.

● Wiring



WARNING

1. Cut off external power supply before wiring.

Not doing so may result in electric shock.

2. Connect AC power supply to the corresponding terminals.

Faulty wiring may result in fire.



CAUTION

1. Do not connect a three-phase power supply to the U, V, or W output terminals.
Doing so may result in injury or fire.
2. Use 2mm² wire to grounding the ground terminals.
Not doing so may result in electric shock.
3. Securely fasten the power supply terminal screws and motor output terminal screws.
Not doing so may result in fire.

● **Operation**



WARNING

1. Never touch any rotating motor parts while the motor is running.
Doing so may result in injury.
2. DO NOT touch the inside the drive.
Doing so may result in electric shock.
3. Do not remove the panel cover while the power is ON.
Doing so may result in electric shock.
4. Do not touch terminals for five minutes after the power has been turned OFF.
Residual voltage may cause electric shock.



CAUTION

1. Conduct trial operation on the servomotor alone with the motor shaft disconnected from machine to avoid any unexpected accidents.
Not doing so may result in injury.
2. Before starting operation with a machine connected, change the settings to match the parameters of the machine.
Starting operation without matching the proper settings may cause the machine to run out of control or malfunction.
3. Before starting operation with a machine connected, make sure that an emergency stop can be applied at any time.
Not doing so may result in injury.
4. Do not touch the heat sinks during operation.
Not doing so may result in burns due to high temperatures.
5. Do not attempt to change wiring while the power is ON.
Doing so may result in electric shock or injury

Catalog

1	Checking Product and Part Names.....	7
1-1.	Checking Products on Delivery	7
1-2.	Product appearance and name rule	7
2	Installations	11
2-1.	Servo motor	11
2-1-1.	Storage Temperature	11
2-1-2.	Installation Site	11
2-1-3.	Concentricity	11
2-1-4.	Orientation.....	12
2-1-5.	Handling Oil and Water.....	12
2-1-6.	Cable Stress	12
2-2.	Servo Drive.....	12
2-2-1.	Storage Conditions	12
2-2-2.	Installation Site	12
2-2-3.	Orientation.....	13
2-2-4.	Installation	13
3	Wiring.....	15
3-1.	DS3-PQA series.....	16
3-1-1.	Main circuit wiring	16
3-1-1-1.	Servo drive terminal arrangement	16
3-1-1-2.	Main circuit terminals	17
3-1-1-3.	Winding Terminals on Servo motor.....	18
3-1-1-4.	CN0, CN1, CN2 terminals	18
3-1-1-5.	Communication port.....	20
3-1-2.	Signal terminals	22
3-1-2-1.	Pulse signal	22
3-1-2-2.	SI input signal	23
3-1-2-3.	SO output signal.....	23
3-1-2-4.	Analog input circuit.....	24
3-1-2-5.	Encoder feedback signal	25
3-1-3.	Standard wiring example.....	25
3-1-3-1.	Position Control Mode	25
3-1-4.	Regenerative Resistor.....	27
3-2.	DS3E/DS3L-PFA	28
3-2-1.	Main circuit wiring	28
3-2-1-1.	The terminal arrangement	28
3-2-1-2.	Main circuit terminals	29
3-2-1-3.	Winding Terminals on Servo motor.....	30
3-2-1-4.	CN0, CN1, CN2 terminals	30
3-2-1-5.	Communication port.....	32
3-2-2.	Signal terminals	34
3-2-2-1.	Pulse signal	34
3-2-2-2.	SI input signal	35
3-2-2-3.	SO output signal.....	35
3-2-2-4.	Analog input circuit.....	36
3-2-2-5.	Encoder feedback signal	36
3-2-3.	Standard wiring example.....	36
3-2-3-1.	Position mode.....	36
3-2-4.	Regenerative resistor	36
3-3.	DS3-PTA series	37
3-3-1.	Main circuit wiring	37
3-3-1-1.	The terminal arrangement	37
3-3-1-2.	Main circuit terminals	37

3-3-1-3. Winding Terminals on Servo motor	39
3-3-1-4. CN0, CN1, CN2 terminals	39
3-3-1-5. Communication port.....	40
3-3-2. Signal terminals	42
3-3-2-1. Pulse signal	42
3-3-2-2. SI input signal	43
3-3-2-3. SO output signal.....	44
3-3-2-4. Analog input circuit.....	45
3-3-2-5. Encoder feedback signal	45
3-3-3. Standard wiring example.....	45
3-3-4. Regenerative resistor	45
4 Use the operate panel	45
4-1. Basic Operation	45
4-1-1. Functions of operate panel.....	45
4-1-2. Basic Mode Switching.....	45
4-2. Running status mode.....	46
4-3. Monitoring Mode.....	47
4-4. Auxiliary Function.....	52
4-4-1. F0-XX.....	52
4-4-2. F1-XX.....	53
4-5. Alarm (E-XXX).....	54
4-6. Example	54
4-7. Change the motor code	55
5 Run the servo system	56
5-1. Control mode selection	56
5-2. Basic function setting.....	56
5-2-1. Servo ON setting	57
5-2-2. Switch the motor rotate direction	57
5-2-3. Stop mode.....	57
5-2-4. Overtravel Limit (P-OT & N-OT)	58
5-2-5. Power-off Brake (BK)	59
5-2-6. Alarm output.....	61
5-2-7. Anti-block run alarm	61
5-3. Position mode (external pulse command).....	61
5-3-1. External position mode.....	62
5-3-2. Pulse command and pulse form.....	62
5-3-3. Electronic gear ratio	63
5-3-4. Position command filter	66
5-3-5. Pulse deviation clear (/CLR)	67
5-3-6. Positioning complete (/COIN, /COIN_HD)	67
5-3-7. Positioning near (/NEAR)	70
5-3-8. Command pulse prohibition (/INHIBIT).....	71
5-3-9. Position pulse difference	71
5-4. Speed control (analog voltage command) (Only for DS3-PQA).....	71
5-4-1. Control mode selection.....	72
5-4-2. Analog value of rated speed	72
5-4-3. Speed command difference auto-adjustment (F1-03).....	73
5-4-4. Proportion action command (/P-CON).....	73
5-4-5. Zero clamp (/ZCLAMP).....	74
5-4-6. Speed coincidence checking (/V-CMP).....	74
5-4-7. Torque limit.....	75
5-4-8. Soft start	76
5-4-9. Filter	77
5-4-10. Speed reach signal (/V-RDY).....	77
5-4-11. Alarm speed.....	78
5-4-12. Speed command input dead area voltage.....	78
5-5. Speed control (internal speed)	78
5-5-1. Control mode selection.....	79

5-5-2. Internal speed setting	79
5-5-3. Input signal setting	79
5-6. Speed control (pulse frequency command).....	81
5-6-1. Control mode selection.....	81
5-6-2. Pulse frequency command.....	81
5-6-3. Command pulse frequency at rated speed	81
5-6-4. Speed command pulse filter time	82
5-7. Torque control (analog voltage command) (only for DS3-PQA).....	82
5-7-1. Control mode selection.....	82
5-7-2. The analog value of rated torque	82
5-7-3. Torque command offset autoadjustment (F1-04)	83
5-7-4. Torque command filter time	83
5-7-5. Torque limit.....	83
5-7-5-1. Internal speed limit.....	83
5-7-5-2. External speed limit.....	84
5-7-5-3. Speed up to limit value output.....	84
5-8. Torque control (internal setting).....	84
5-8-1. Control mode selection.....	85
5-8-2. Internal torque command.....	85
5-9. Motion fieldbus control (position mode) (only for DS3E)	85
5-10. Absolute encoder servo drive	86
5-10-1. Absolute encoder servo encoder cable	87
5-10-2. Read the absolute encoder servo position.....	87
5-10-3. The use and replacement of battery	88
5-11. Other output signals.....	88
5-11-1. /ALM and /ALM-RST.....	88
5-11-2. /WARN.....	89
5-11-3. Rotation checking (/TGON).....	89
5-11-4. Hysteresis loop	90
5-11-5. Servo ready (/S-RDY)	90
5-11-6. Encoder Z phase output (/Z) (only for DS3-PQA/DS3-PTA).....	90
5-11-7. ABZ phase feedback signal of encoder (CN1 15-pin support).....	91
5-11-8. User-defined output signal.....	92
5-11-9. IO filter time	93
5-11-10. Switch the control mode	93
5-12. I/O signal distribution	94
5-12-1. Input signal distribution.....	94
5-12-2. Default setting of input terminal.....	95
5-12-3. Output terminal distribution	95
5-12-4. Default setting of output terminal.....	95
5-13. DS3-PTA series absolute encoder servo drive.....	95
5-13-1. Read the absolute encoder position	96
5-13-2. Battery using and changing	97
5-14. Internal position mode (only for DS3E/DS3L).....	97
5-14-1. Control mode selection.....	98
5-14-2. Internal position mode	98
5-14-3. Position parameters from segment 1 to 35	101
5-14-4. Change step (/CHGSTP)	102
5-14-5. Pause current segment signal (/INHIBIT)	102
5-14-6. Skip current segment signal (/ZCLAMP).....	102
5-14-7. Reference origin	102
5-14-8. Set segment through communication.....	104
5-14-9. Motion start signal (/MRUN).....	104
6 Servo gain adjustment.....	105
6-1. Gain parameter adjustment	105
6-1-1. Gain parameters.....	105
6-1-2. Other parameters	106
6-2. Parameter switching.....	107
6-2-1. G-SEL signal input.....	108

6-3. The experience of gain adjustment	108
7 Specification and dimension	109
7-1. Servo motor	109
7-1-1. Servo motor specification	109
7-1-2. Torque-Speed Feature	113
7-1-3. Servo motor dimensions	115
7-2. Servo drives	119
7-2-1. DS3E, DS3L, DS3-PTA, DS2 comparison table.....	119
7-2-2. Servo drive dimensions	121
8 Alarm Information	124
Appendix 1 Parameter list	130
Appendix 2 UX-XX monitoring parameters	139
Appendix 3 FX-XX auxiliary function	142
Appendix 4 Modbus address.....	142
Appendix 5 General debug steps.....	145
Appendix 6 Application	146
Appendix 7 Compatible table of servo and motor	148

1 Checking Product and Part Names

1-1. Checking Products on Delivery

Use the following checklist when products are delivered.

Items	Comments
Are the delivered products the ones that were ordered?	Check the model numbers marked on the nameplates of the servomotor and servo drive.
Does the servomotor shaft rotate smoothly?	The servomotor shaft is normal if it can be turned smoothly by hand. Servomotors with brakes, however, cannot be turned manually.
Is there any damage?	Check the overall appearance, and check for damage or scratches that may have occurred during shipping.
Are there any loose screws?	Check screws for looseness using a screwdriver.
Is the motor code the same with the code in drive?	Check the motor code marked on the nameplates of the servomotor and the parameter P0-33 on the servo drive.

If any of the above is faulty or incorrect, contact Xinje or an authorized distributor.

1-2. Product appearance and name rule

- DS3-2□P□-PQA/ DS3-4□P□-PQA/ DS3E-2□P□-PFA/ DS3E-4□P□-PFA

Appearance and nameplate

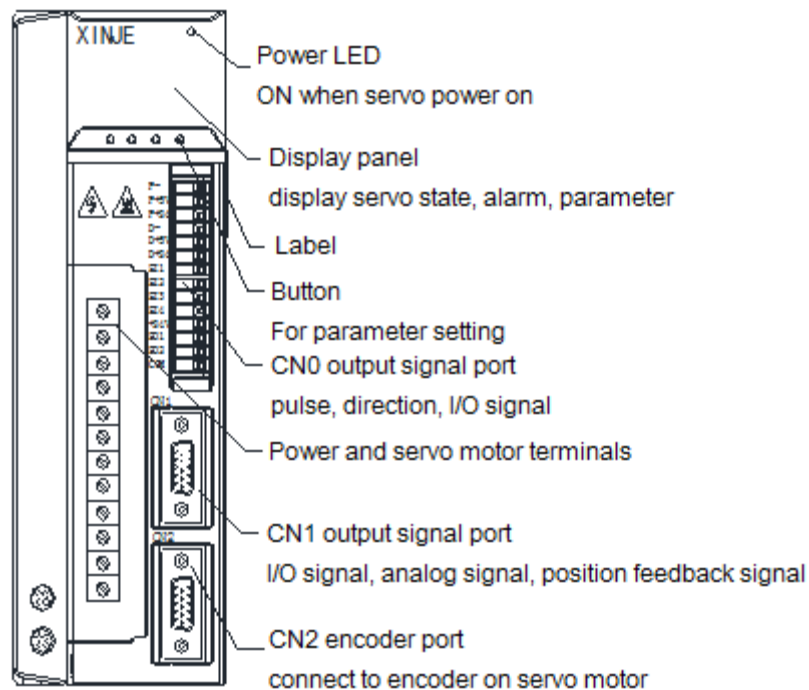

Servo drive nameplate

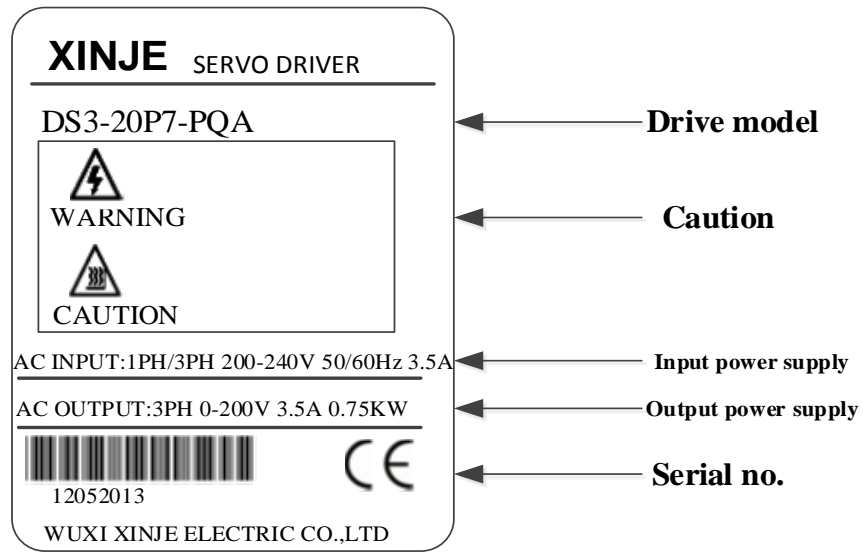

(1) Naming rule

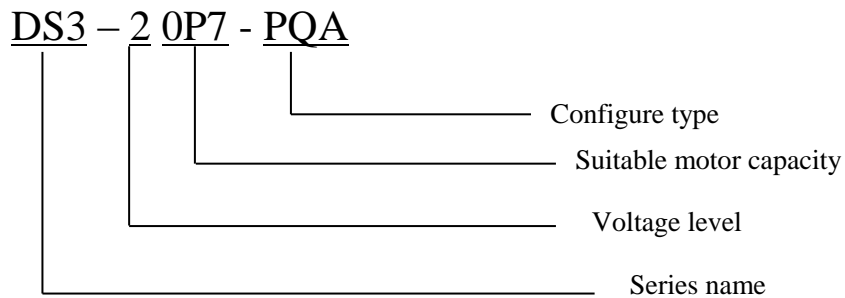

Series	DS3	DS3 series high precision servo drive
	DS3E	DS3E series filedbus servo drive
		DS3L series pulse-type servo drive
Voltage level	2	220V
	4	380V
Suitable motor capacity	0P2	0.2 KW
	0P4	0.4KW
	0P7	0.75KW
	1P5	1.5KW
	2P3	2.3KW
	3P0	3.0KW
	5P5	5.5KW
Configuration type	P	Input command type: pulse
	Encoder type	Q-quadrature encoder
		F-compatible quadrature encoder
		T-17 bits absolute value encoder
A	Design order: A	

■ **Servo motor**

(1) Appearance and nameplate

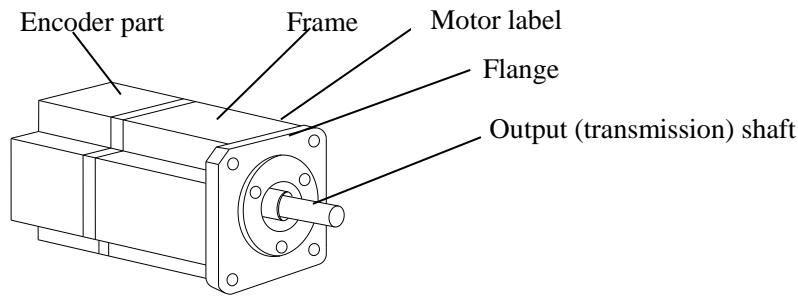

Motor label

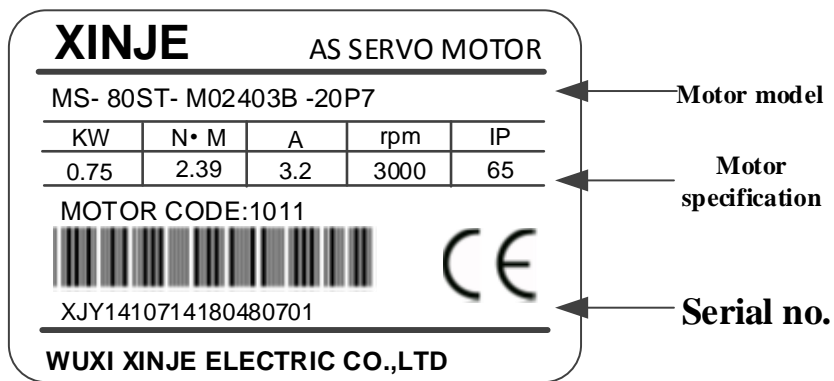

(2) Naming rule

MS -80 ST E- M 02430 B Z S- 2 0P7 - S

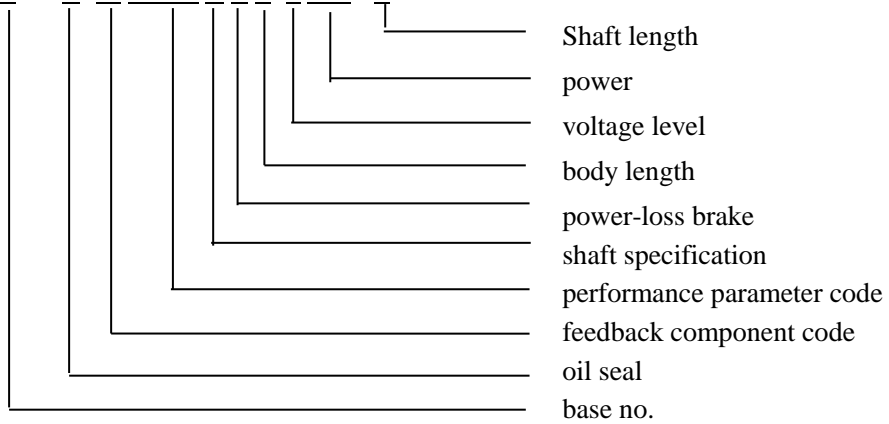

Base number	40, 60, 80, 90, 110, 130, 180, 220	
Oil seal	Empty	Without oil seal (130ST and above models all have oil seal, so the model without E)
	E	With oil seal (60ST, 80ST model name has differences)
Feedback component no.	M	Incremental encoder (2500ppr optical pulse encoder)
	F	Line-saving incremental encoder (2500ppr optical pulse encoder)
	T	17 bits absolute value encoder
	N	20 bits absolute value encoder
Performance parameter no.	<p>First 3 bits mean rated torque, last 2 bits mean rated speed Such as: 00630: rated torque 0.6N.m, rated speed 3000rpm 06025: rated torque 6.0N.m, rated speed 2500rpm 19015: rated torque 19.0N.m, rated speed 1500rpm</p>	
Shaft spec	A	No bond
	B	With bond
Power-loss brake	Vacant	No
	Z	With power-off brake
Body length	Vacant	Normal models
	S	Short body
Voltage level	2	220V
	4	380V
Power	<p>Such as: 0P4: 0.4kW 0P7: 0.75kW 1P5: 1.5KW</p>	
Motor shaft length Note: only 180ST has differences	vacant	Normal models
	S	Short shaft

2 Installations

2-1. Servo motor

MS series servomotors can be installed either horizontally or vertically. The service life of the servomotor can be shortened or unexpected problems might occur if it is installed incorrectly or in an inappropriate location. Follow these installation instructions carefully.



CAUTION

1. The end of the motor shaft is coated with antirust. Before installing, carefully remove all of the paint using a cloth moistened with paint thinner.
2. Avoid getting thinner on other parts of the servomotor.

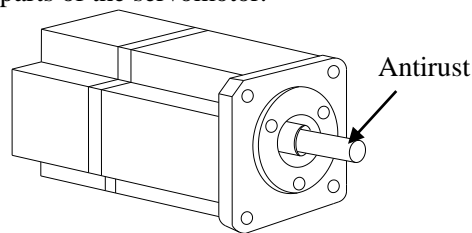

2-1-1. Storage Temperature

Store the servomotor within $-20\sim+60\text{ }^{\circ}\text{C}$ as long as it is stored with the power cable disconnected.

2-1-2. Installation Site

MS series servomotors are designed for indoor use. Install the servomotor in environments that satisfy the following conditions.

- Free of corrosive or explosive gases.
- Well-ventilated and free of dust and moisture.
- Ambient temperature of 0 ° to $50\text{ }^{\circ}\text{C}$.
- Relative humidity (r.h.) of 20 to 90% with no condensation.
- Accessible for inspection and cleaning.

2-1-3. Concentricity

Please use coupling when connecting to machine; keep the shaft center of servo motor and machine at the same line. It should be accord to the following diagram when installing the servo motor.

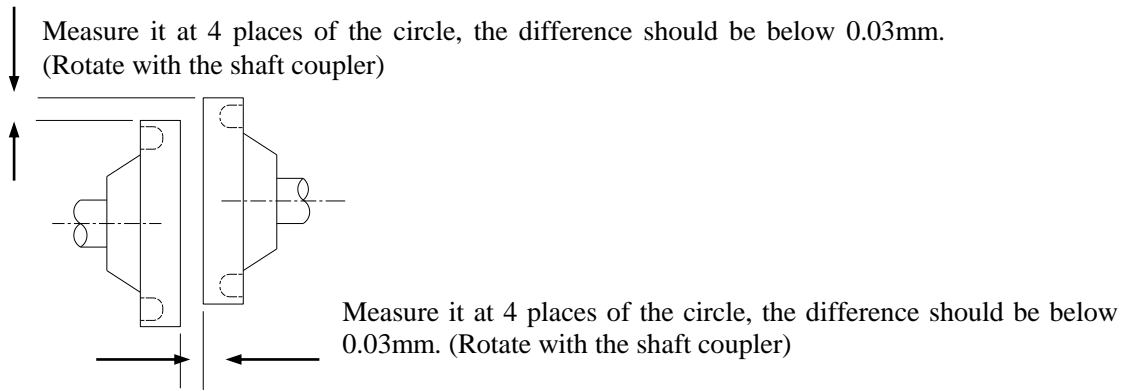

Note: (1) If the concentricity is not enough, it will cause the vibration and bearing damage.
 (2) When installing the coupler, prevent direct impact to the shaft. This can damage the encoder mounted on the shaft end at the opposite side of the load.

2-1-4. Orientation

MS series servomotors can be installed either horizontally or vertically.

2-1-5. Handling Oil and Water

Install a protective cover over the servomotor if it is used in a location that is subject to water or oil mist. Also use a servomotor with an oil seal when needed to seal the through-shaft section.

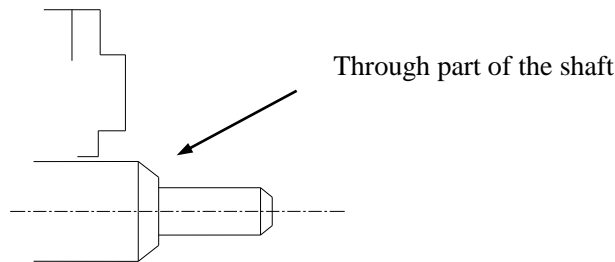

2-1-6. Cable Stress

Make sure that the power lines are free from bends and tension. Be especially careful to wire signal line cables so that they are not subject to stress because the core wires are very thin, measuring only 0.2 to 0.3mm².

2-2. Servo Drive

The DS3 series PQA servo drives are base-type servo drive. Incorrect installation will cause problems. Follow the installation instructions below

2-2-1. Storage Conditions

Store the servo drive within -20~+60°C, as long as it is stored with the power cable disconnected.

2-2-2. Installation Site

The following precautions apply to the installation site.

Situation	Installation Precaution
Installation in a Control Panel	Design the control panel size, unit layout, and cooling method so the temperature around the servo drives does not exceed 50 °C.

Installation Near a Heating Unit	Minimize heat radiated from the heating unit as well as any temperature rise caused by natural convection so the temperature around the servo drives does not exceed 50 °C.
Installation Near a Source of Vibration	Install a vibration isolator beneath the servo drive to avoid subjecting it to vibration.
Installation at a Site Exposed to Corrosive Gas	Corrosive gas does not have an immediate effect on the servo drives, but will eventually cause electronic components and terminals to malfunction. Take appropriate action to avoid corrosive gas.
Other Situations	Do not install the servo drive in hot and humid locations or locations subject to excessive dust or iron powder in the air.

2-2-3. Orientation

Install the servo drive perpendicular to the wall as shown in the figure. The servo drive must be oriented this way because it is designed to be cooled by natural convection or by a cooling fan.

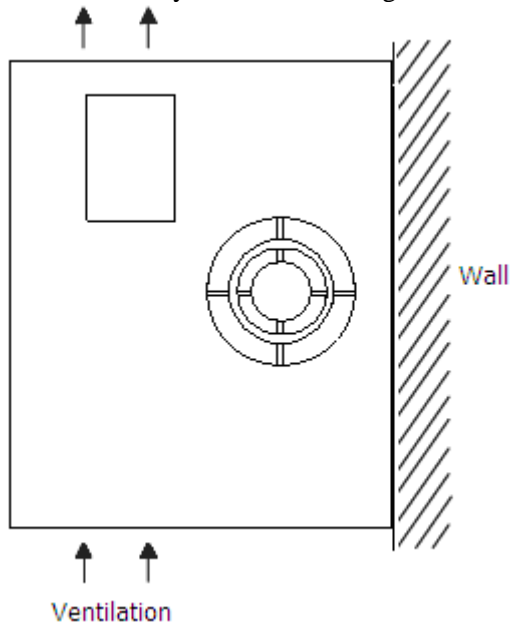

2-2-4. Installation

Follow the procedure below to install multiple servo drives side by side in a control panel.

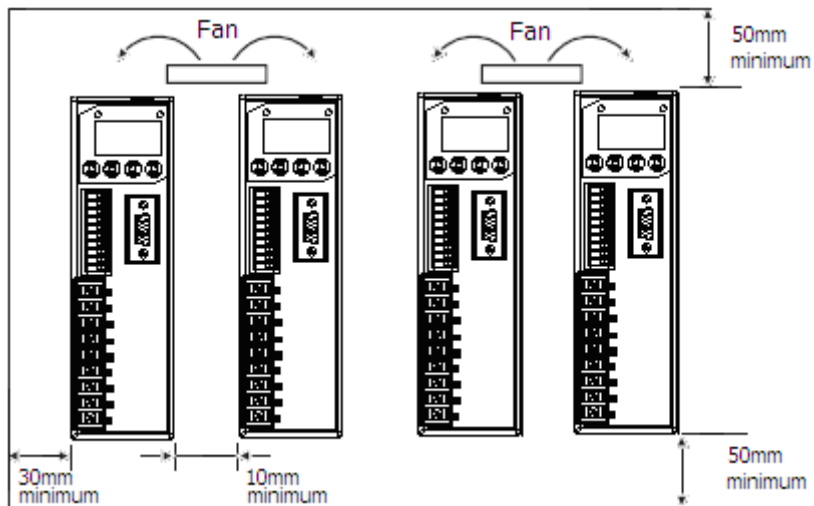

■ Servo Drive Orientation

Install the servo drive perpendicular to the wall so the front panel containing connectors faces outward.

■ Cooling

As shown in the figure above, allow sufficient space around each servo drive for cooling by cooling fans or natural convection.

■ Side-by-side Installation

When install servo drives side by side as shown in the figure above, make at least 10mm between and at least 50mm above and below each servo drive. Install cooling fans above the servo drives to avoid excessive temperature rise and to maintain even temperature inside the control panel.

■ Environmental Conditions in the Control Panel

- Ambient Temperature: 0~50 °C
- Humidity: 90%RH or less
- Vibration: 4.9m/s²
- Condensation and Freezing: None
- Ambient Temperature for Long-term Reliability: 50 °C maximum

3 Wiring

Servo drive cable table:

Servo drive	Power supply cable diameter mm ²	UVW power cable diameter mm ²	Encoder cable diameter mm ²	Ground cable diameter mm ²
DS3-20P2-PQA DS3E-20P2-PFA DS3L-20P2-PFA DS3-20P2-PTA	2.0	0.75	0.2 (14 cores)	2.0
DS3-20P4-PQA DS3E-20P4-PFA DS3L-20P4-PFA DS3-20P4-PTA	2.0	0.75	0.2 (14 cores)	2.0
DS3-20P7-PQA DS3E-20P7-PFA DS3L-20P7-PFA DS3-20P7-PTA	2.0	0.75	0.2 (14 cores)	2.0
DS3-21P5-PQA DS3E-21P5-PFA DS3L-21P5-PFA DS3-21P5-PTA	2.0	1.5	0.2 (14 cores)	2.0
DS3-22P3-PQA DS3E-22P3-PFA DS3L-22P3-PFA DS3-22P3-PTA	2.0	1.5	0.2 (14 cores)	2.0
DS3E-22P6-PFA DS3L-22P6-PFA	2.0	1.5	0.2 (14 cores)	2.0
DS3-41P5-PQA DS3E-41P5-PFA DS3L-41P5-PFA DS3-41P5-PTA	2.0	1.5	0.2 (14 cores)	2.0
DS3-43P0-PQA DS3E-43P0-PFA DS3L-43P0-PFA DS3-43P0-PTA	2.0	2.5	0.2 (14 cores)	2.0
DS3-45P5-PQA DS3L-45P5-PQA DS3-47P5-PQA DS3L-47P5-PQA	6.0	6.0	0.2 (14 cores)	6.0
DS3-411P0-PQA DS3-415P0-PQA	10.0	10.0	0.2 (9 cores)	10.0



Caution

1. Do not bundle or run power and signal lines together in the same duct. Keep power and signal lines separated by at least 11.81inch(30cm)
2. Use twisted pair wires or multi-core shielded-pair wires for signal and encoder (PG) feedback lines.
The maximum length is 118.11 inch (3m) for reference input lines and is 787.40 inch (20m) for encoder (PG) feedback lines.
3. Do not touch the power terminals for 5 minutes after turning power OFF because high voltage may still remain in the servo amplifier.
Please make sure to check the wiring after the CHARGE light is going off.
4. Avoid frequently turning power ON and OFF. Do not turn power ON or OFF more than once per

minute.

Since the servo amplifier has a capacitor in the power supply, a high charging current flows for 0.2s when power is turned ON. Frequently turning power ON and OFF causes main power devices like capacitors and fuses to deteriorate, resulting in unexpected problems.

3-1. DS3-PQA series

3-1-1. Main circuit wiring

3-1-1-1. Servo drive terminal arrangement

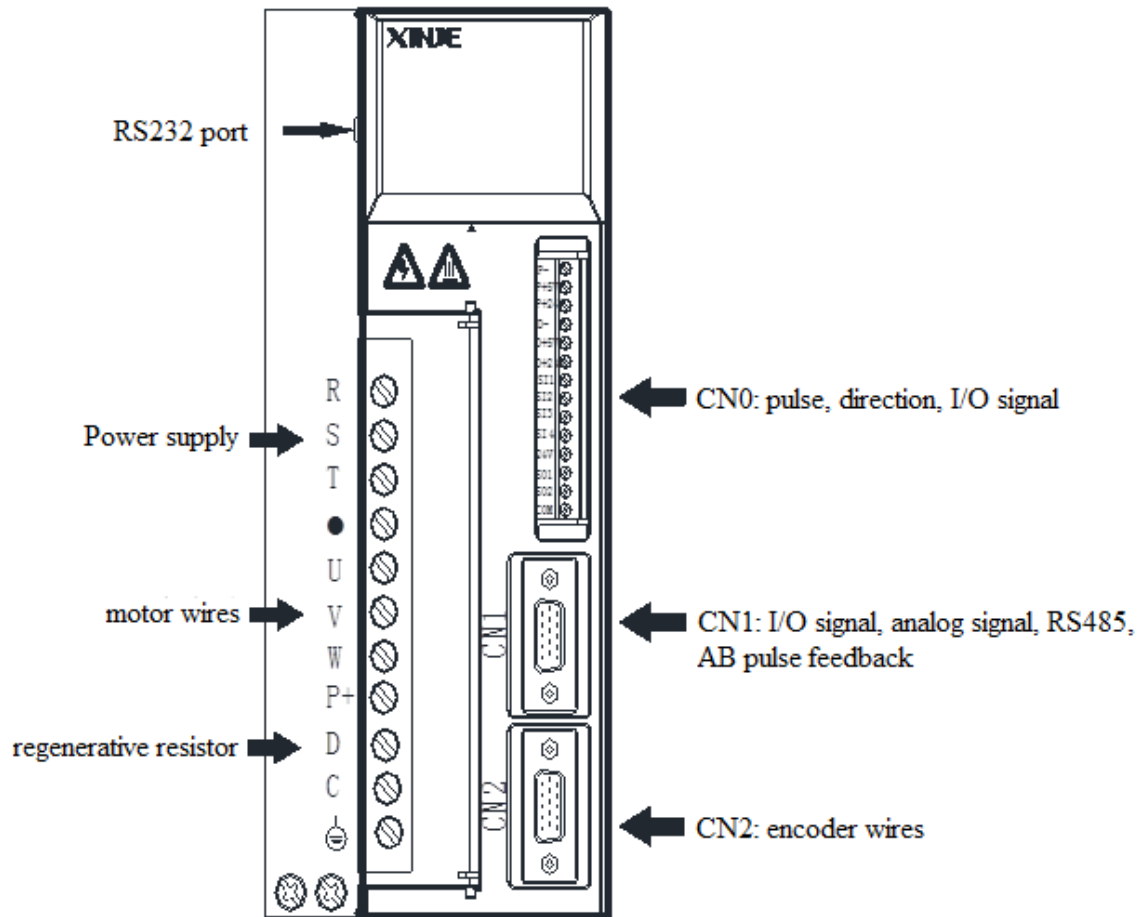

3-1-1-2. Main circuit terminals

		■ DS3-20P2-PQA, DS3-20P4-PQA, DS3-20P7-PQA											
Terminal	Function	Explanation											
L1/L2/L3	Power supply input of main circuit	Single or 3 phase AC 200 ~ 240V, 50/60Hz Note: for single phase 220V, connect power supply to L1, L3, otherwise it will affect the power-off retentive function											
●	Vacant terminal	-											
U, V, W	Motor terminals	Connect the motor <table border="1"> <thead> <tr> <th>Terminal</th> <th>Color</th> </tr> </thead> <tbody> <tr> <td>U</td> <td>brown</td> </tr> <tr> <td>V</td> <td>black</td> </tr> <tr> <td>W</td> <td>blue</td> </tr> <tr> <td>PE</td> <td>Yellow green</td> </tr> </tbody> </table> Note: the ground line is on the cooling fin, please check it before power on! Do not connect to P+ or P-!		Terminal	Color	U	brown	V	black	W	blue	PE	Yellow green
Terminal	Color												
U	brown												
V	black												
W	blue												
PE	Yellow green												
P+, D, C	Internal regenerative resistor	Short P+ and D, disconnect P+ and C, set P0-24=0											
	External regenerative resistor	Connect regenerative resistor between P+ and C, disconnect P+ and D, set P0-24=1, P0-25= power value, P0-26= resistor value (see chapter 3-4)											
P+/P-	Bus terminal	Real-time check the bus voltage, please take attention of this terminal											
		■ DS3-21P5-PQA, DS3-22P3-PQA, DS3-41P5-PQA											
Terminal	Function	Explanation											
R/S/T	Power supply input of main circuit	DS3-21P5/22P3-PQA 3 phase AC 200~240V, 50/60Hz Note: for single phase 220V, connect power supply to terminal R, T, otherwise it will affect the power-off retentive function. DS3-41P5-PQA 3 phase AC 360~400V, 50/60Hz											
●	Vacant	-											
U, V, W	Motor terminals	Connect the motor <table border="1"> <thead> <tr> <th>Terminal</th> <th>Color</th> </tr> </thead> <tbody> <tr> <td>U</td> <td>brown</td> </tr> <tr> <td>V</td> <td>black</td> </tr> <tr> <td>W</td> <td>blue</td> </tr> <tr> <td>PE</td> <td>Yellow green</td> </tr> </tbody> </table>		Terminal	Color	U	brown	V	black	W	blue	PE	Yellow green
Terminal	Color												
U	brown												
V	black												
W	blue												
PE	Yellow green												
P+, D, C	Internal regenerative resistor	Short P+ and D, disconnect P+ and C, set P0-24=0											
	External regenerative resistor	Connect regenerative resistor between P+ and C, disconnect P+ and D, set P0-24=1, P0-25=power value, P0-26=resistor value (see chapter 3-1-4)											
⊕	Ground	Connect to ground terminal of motor, then connect to the ground											

DS3-43P0-PQA												
Terminal	Function	Explanation										
R/S/T	Power supply input of main circuit	3 phase AC 360~400V, 50/60Hz										
•	Vacant											
U, V, W	Motor terminals	Connect the motor <table border="1" style="margin-left: 20px;"> <thead> <tr> <th>Terminal</th> <th>Color</th> </tr> </thead> <tbody> <tr> <td>U</td> <td>brown</td> </tr> <tr> <td>V</td> <td>black</td> </tr> <tr> <td>W</td> <td>blue</td> </tr> <tr> <td>PE</td> <td>Yellow green</td> </tr> </tbody> </table> <p style="color: red; margin-left: 20px;">Note: the ground line is on the cooling fin, please check it before power on! Do not connect to P+ or P-!</p>	Terminal	Color	U	brown	V	black	W	blue	PE	Yellow green
Terminal	Color											
U	brown											
V	black											
W	blue											
PE	Yellow green											
P+, D, C	Internal regenerative resistor	Short P+ and D, disconnect P+ and C, set P0-24=0										
	External regenerative resistor	Connect regenerative resistor between P+ and C, disconnect P+ and D, set P0-24=1, P0-25=power value, P0-26=resistor value (see chapter 3-1-4)										
P+/P-	Bus terminal	Real-time check the bus voltage, please take attention of this terminal										

3-1-1-3. Winding Terminals on Servo motor

Symbol	40, 60, 80, 90 Series	110, 130, 180 Series
PE	4-yellow green (yellow green)	1-yellow green
U	1-brown (red)	2-brown
V	3-black (blue)	3-black
W	2-blue (yellow)	4-blue
Terminal for brake	1: +24V 2: GND	

3-1-1-4. CN0, CN1, CN2 terminals

CN0	CN1(DB15 male port) drive side	CN2(DB15 female port) drive side
P- P+5V P+24V D- D+5V D+24V SI1 SI2 SI3 SI4 +24V SO1 SO2 COM		

■ CN0 terminals

No.	Name	Explanation	No.	Name	Explanation
1	P-	Pulse input PUL-	8	SI2	Input 2
2	P+5V	5V difference input	9	SI3	Input 3
3	P+24V	Open collector input	10	SI4	Input 4
4	D-	Direction input DIR-	11	+24V	Input +24V
5	D+5V	5V difference input	12	SO1	Output 1
6	D+24V	Open collector input	13	SO2	Output 2
7	SI1	Input 1	14	COM	Ground of output

■ CN1 (DB15) terminals

DS3 series 750W and below servo drive (hardware version v3.1.20)

No.	Name	Explanation	No.	Name	Explanation
1	GND	GND-485	9	Z-	Encoder output Z-
2	A1	RS485+	10	B+	Encoder output B+
3	B1	RS485-	11	T-REF	Torque analog input
4	VCC	VCC-RS485	12	V-REF	Speed analog input
5	B-	Encoder output B-	13	GND	GND for analog input
6	A+	Encoder output A+	14	A2	RS485+
7	A-	Encoder output A-	15	B2	RS485-
8	Z+	Encoder output Z+			

DS3 series above 750W servo drive

No.	Name	Explanation	No.	Name	Explanation
1	NC	Reserved	9	Z-	Encoder output Z-
2	NC	Reserved	10	B+	Encoder output B+
3	SI5	Input 5	11	T-REF	Torque analog input
4	SO3	Output 3	12	V-REF	Speed analog input
5	B-	Encoder output B-	13	GND	GND for analog input
6	A+	Encoder output A+	14	A	RS485+
7	A-	Encoder output A-	15	B	RS485-
8	Z+	Encoder output Z+			

DS3 series 5.5KW and 7.5KW servo drive (only these two models use 9-pin port)

No.	Name	Explanation	No.	Name	Explanation
1	GND	GND-485	2	A1	RS485+
3	B1	RS485-	4	A2	RS485+
5	B2	RS485-	6	GND	GND-485
7	NC	Reserved	8	NC	Reserved
9	NC	Reserved			

■ CN2 terminals

Drive port	Motor encoder port		Name	Drive port	Motor encoder port		Name
	60, 80, 90 series	110, 130, 180 series			60, 80, 90 series	110, 130, 180 series	
1	9	4	A+	2	4	5	B+
3	7	6	Z+	4	6	10	U+
5	11	12	W+	6	13	7	A-
7	14	8	B-	8	5	9	Z-

9	8	13	U-	10	15	15	W-
11	1	1	Connect to shield layer	12	3	3	GND
13	2	2	5V	14	10	11	V+
15	12	14	V-				

3-1-1-5. Communication port

■ RS-232 communication

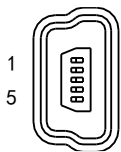
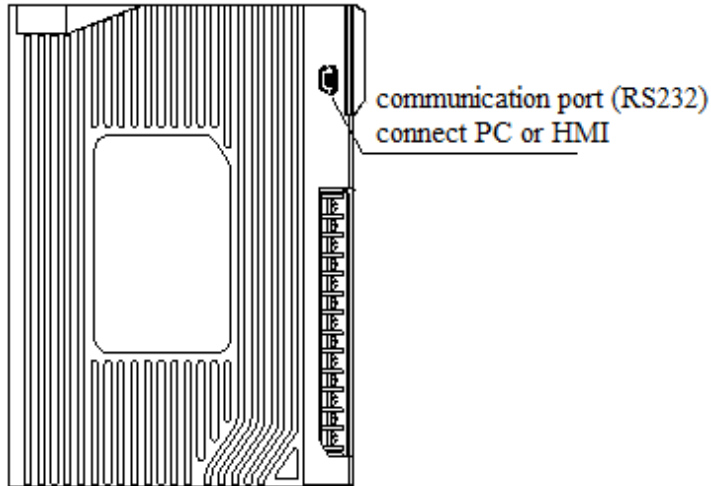

(5-pin port)

Pin no.	Name	Explanation
1	TXD	RS232 send
2	RXD	RS232 receive
3	GND	RS232 ground

Note: please use the cable supplied by XINJE Company

Communication parameters:

RS232 default communication parameters: baud rate 19200bps, data bit 8, stop bit 1, even parity.

Modbus station no. setting:

Parameter	Function	Default setting	Range	Modify	Effective
P7-10	Modbus station no.	1	1~255	Servo OFF	At once

Please set the following parameters through P7-11:

Parameter no.	Function	Default value	Range	Effective time
n.xx□□	Baud rate	06	00~10 00: 300 01: 600 02: 1200 03: 2400 04: 4800 05: 9600 06: 19200 07: 38400 08: 57600 09: 115200	At once

			0A: 192000 0B: 256000 0C: 288000 0D: 384000 0E: 512000 0F: 576000 10: 768000	
n.X□XX	Stop bit	2	0: 2 bits, 2: 1 bit	At once
n.□XXX	Parity bit	2	0~2 0:no parity, 1: odd parity, 2: even parity	At once
Note: data bit cannot be changed, it is 8 bits.				

■ RS-485 port

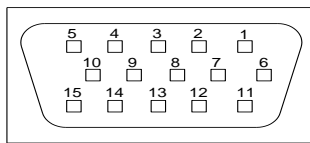

Pin no.	Name
CN1-14	A
CN1-15	B

Communication parameters:

RS485 default communication parameters: baud rate 19200bps, data bit 8, stop bit 1, even parity, Modbus station no.1.

The Modbus station no. can be set through P7-00:

Parameter	Function	Default value	Range	Effective time
P7-00	Modbus station no.	1	0~255	At once

The communication parameters can be set through P7-01:

Parameter	Function	Default value	Range	Effective time
n.XX□□	Baud rate	06	00~10 00: 300 01: 600 02: 1200 03: 2400 04: 4800 05: 9600 06: 19200 07: 38400 08: 57600 09: 115200 0A: 192000 0B: 256000 0C: 288000 0D: 384000 0E: 512000 0F: 576000 10: 768000 11: 1M 12: 2M 13: 3M 14: 4M 15: 5M	At once

			16: 6M	
n.X□XX	Stop bit	2	0: 2 bits, 2: 1 bit	At once
n.□XXX	Parity bit	2	0~2 0:no parity, 1: odd parity, 2: even parity	At once
Note: data bit cannot be changed, it is 8 bits.				

P7-02 RS485 communication protocol setting:

Parameter	Function	Default setting	Range	Modify	Effective
P7-02	RS485 communication protocol	1	1: Modbus Rtu protocol 2: Xnet filedbus protocol	Servo OFF	At once



1. Support standard Modbus RTU protocol, it is used as Modbus slave device.
2. RS232 port and RS485 port can be used at the same time.

3-1-2. Signal terminals

3-1-2-1. Pulse signal

Command	Choice	Meaning	P-input signal	D-input signal	Chapter
P0-10 xxx□	0	CW, CCW double pulse mode	CW	CCW	5-3-2
	1	AB phase mode	A phase	B phase	
	2	Pulse + direction mode	Pulse	Direction	
Collector open circuit (24V) input positive signal: P+24V/D+24V Differential mode (5V) input positive signal: P+5V/D+5V					

The interface circuit of Pulse + direction and CW, CCW mode:

DS3-2□P□-PQA DS3-4□P□-PQA	Open collector (24V)
	<div style="display: flex; justify-content: space-between;"> <div style="width: 45%;"> <p>PLC, SCM, etc</p> </div> <div style="width: 45%;"> <p>servo drive</p> <p>When upper device is open collector output, please use this wiring diagram. Please note: P+5V and D+5V must be vacant.</p> </div> </div> <p>Note:</p> <ol style="list-style-type: none"> (1) P-/P+24V, D-/D+24V power supply range is 18~25V. if the voltage is lower than 18V, the pulse and direction will be error. (2) To avoid the interference, please use shielded twisted-pair cable.
DS3-2□P□-PQA	Differential mode (5V)

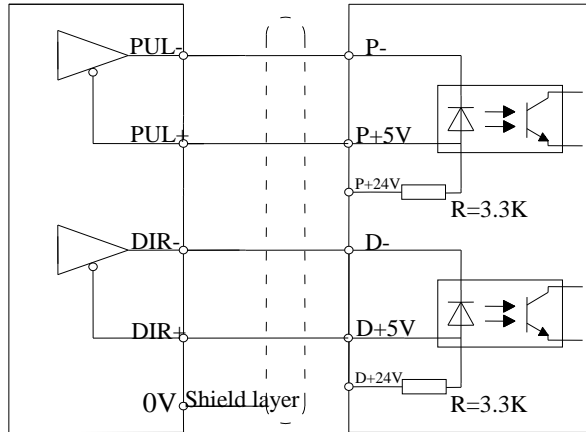

When upper device is 5V differential output, please use this wiring diagram. Please note: P+24V and D+24V must be vacant.

To avoid the interference, please use shielded twisted-pair cable.



- (1) Servo pulse input will be ON at 10mA.
- (2) If the controller is XINJE PLC, pulse output rated current is 50mA, so 1 channel of pulse can connect 5 servo drives. We suggest not over 3 servo drives.

3-1-2-2. SI input signal

Please use relay or open collector transistor to connect. When using relay, please choose micro-current relay. Otherwise, the contact will be not good.

Type	Input terminal	Function	Reference chapter
Digital input	SI1~SI5	Multi-functional input	5-12-1

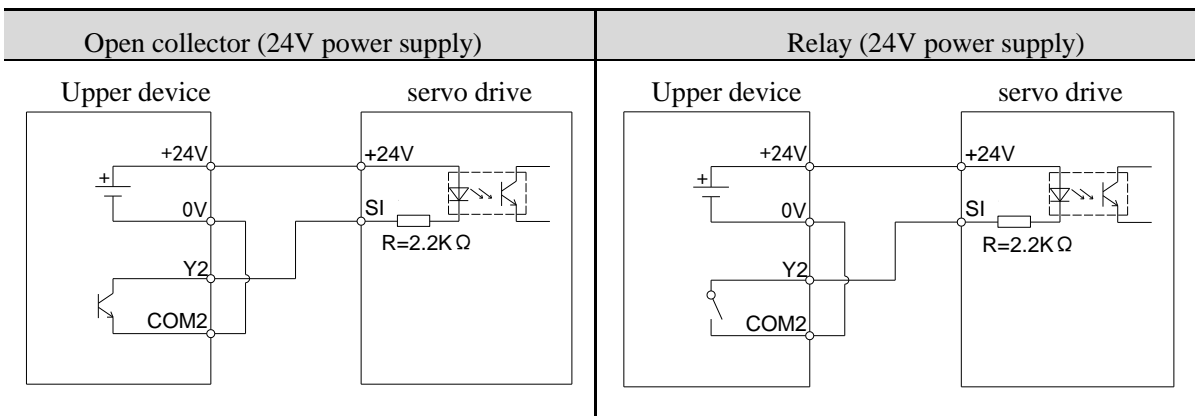

Note: the max allowable voltage and current of open collector output circuit:

Voltage: max DC30V

Current: max DC50mA

3-1-2-3. SO output signal

Type	Output terminal	Function	Reference chapter
Optocoupler output	SO1~SO3	Multiple functions output terminal	5-12-3

Optocoupler type

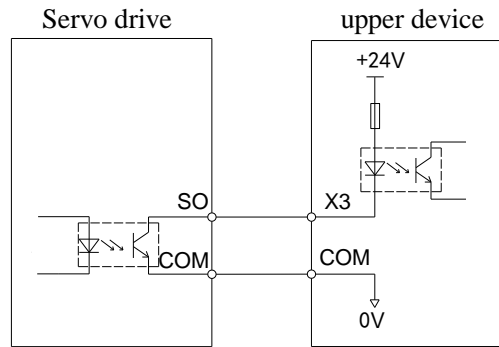

Relay type

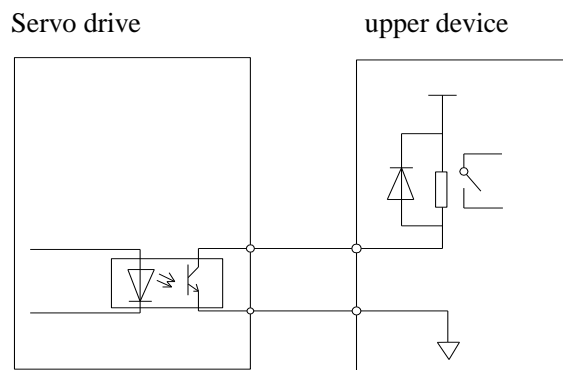

Note: max load current 400mA (if control the brake motor by SO signal, please confirm the brake current, if it is larger than 400mA, please use intermediate relay)

3-1-2-4. Analog input circuit

DS3-2□P□-PQA
DS3-4□P□-PQA

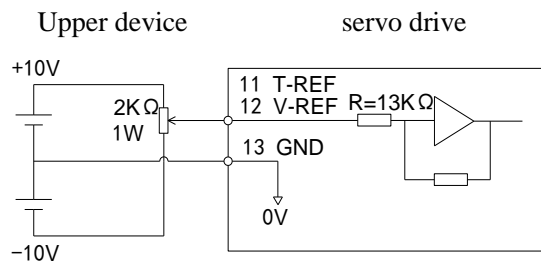

Note: analog terminal 11 (T-REF analog torque), 12(T-REF analog speed), 13(analog GND) come from CN1 DB15, refer to chapter 3-1-1-4.

- Analog signal is speed command or torque command. Input impedance:
- speed command input: about 13KΩ
 - torque command input: about 13KΩ
 - max allowable voltage of input signal is ±10V

3-1-2-5. Encoder feedback signal

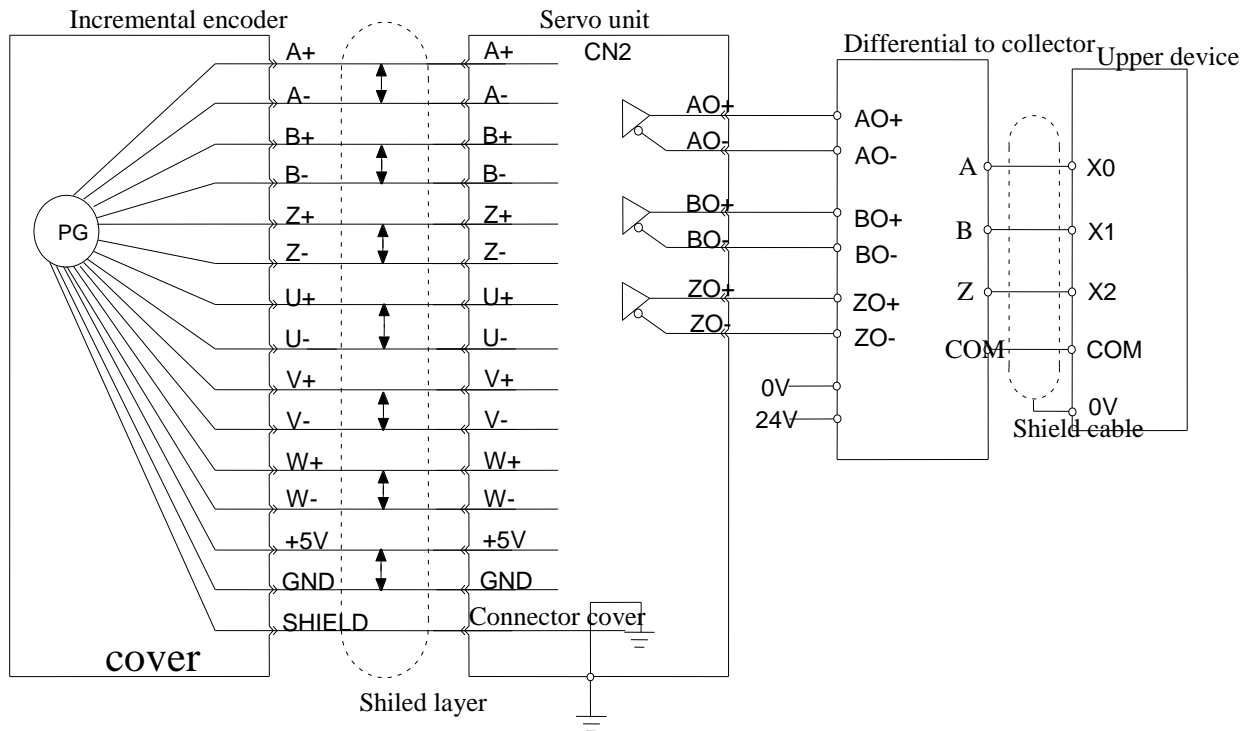

3-1-3. Standard wiring example

For the following wiring diagram, the input and output terminal function is out of factory settings. The setting can be changed, please see chapter 5-12.

3-1-3-1. Position Control Mode

- DS3-21P5-PQA

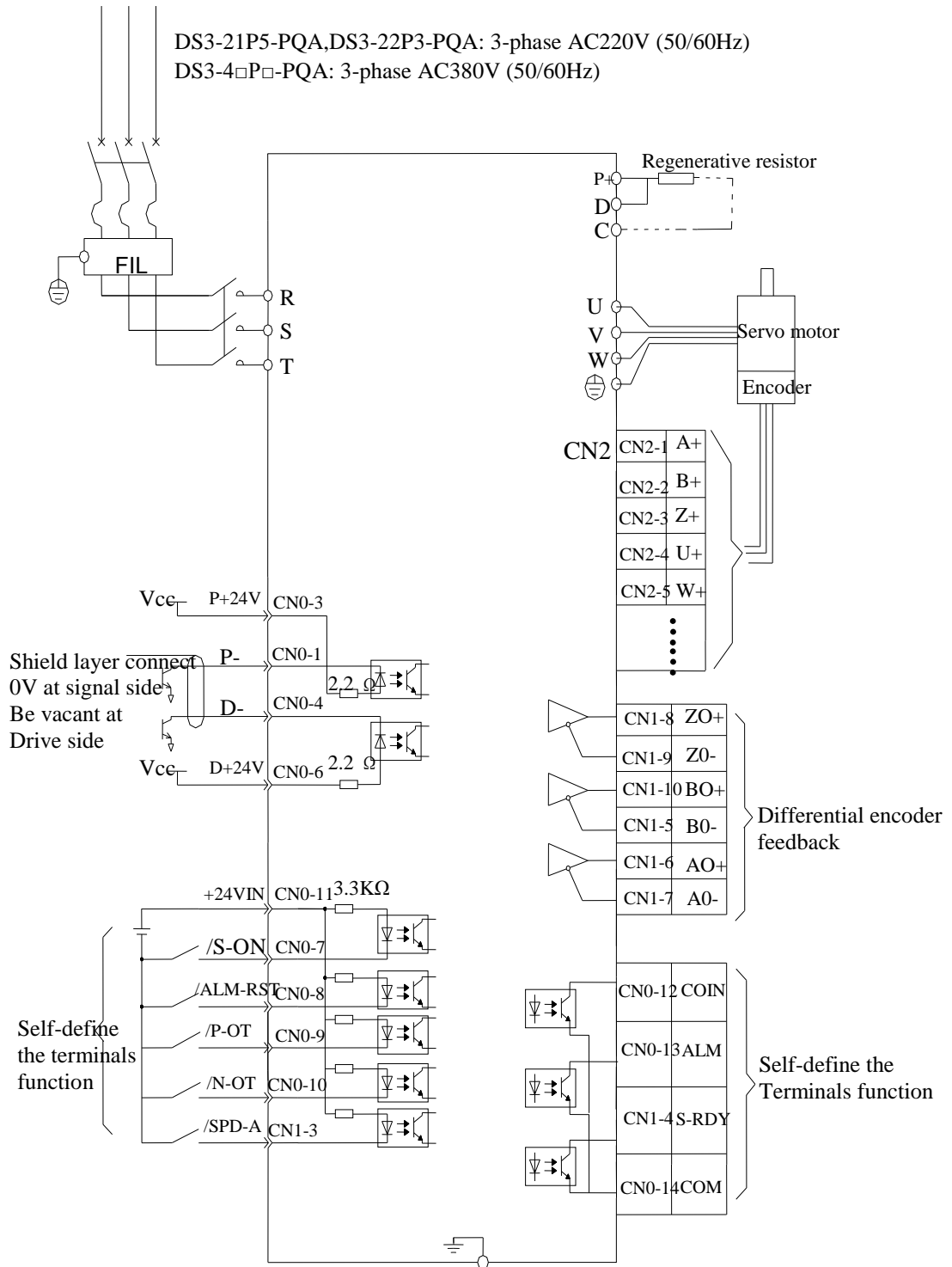

3-1-4. Regenerative Resistor

When the servo motor operates in generator mode, power is returned to the servo drive side. This is called regenerative power. The regenerative power is absorbed by charging the smoothing capacitor, but when the capacitor's charging limit is exceeded, the regenerative power needs to be reduced by the regenerative resistor.

The servomotor is driven in regeneration (generator) mode in the following conditions:

- From decelerating to stop for acceleration/deceleration operation.
- Move down on the vertical axis.
- The external load drives the motor running

Servo drive	Regenerative resistor connection terminals
DS3-2□P□-PQA DS3-4□P□-PQA DS3E-2□P□-PFA DS3E-4□P□-PFA DS3L-2□P□-PFA DS3L-4□P□-PFA DS3-2□P□-PTA DS3-4□P□-PTA	for internal regenerative resistor: short P+ and D, disconnect P+ and C, P0-24=0. for external regenerative resistor: connect resistor between P+ and C, disconnect P+ and D, P0-24=1, P0-25=power value, P0-26=resistor value.

Parameter	Signal name	Setting	Meaning	Effective	Modify
P0-24	Choose regenerative resistor	0	Use internal regenerative resistor	At once	Servo OFF
		1	Use external regenerative resistor (resistor type please refer to the following table)		

Parameter	Signal name	Setting	Unit	Effective
P0-25	Discharge resistor power	1. self-cooling mode (natural convection cooling): below 20% of regenerative resistor capacity (W) 2. forced air cooling: below 50% of regenerative resistor capacity (W)	W	At once
P0-26	Discharge resistor value	Resistor value	Ω	At once

The type of regenerative resistor:

Servo drive	Min resistor (cannot smaller than this value)	External regenerative resistor (recommend value)	External regenerative resistor (recommend power)
DS3-20P2-PQA DS3E-20P2-PFA DS3L-20P2-PFA DS3-20P2-PTA	50Ω	50Ω—100Ω	Above 200W
DS3-20P4-PQA DS3E-20P4-PFA DS3L-20P4-PFA DS3-20P4-PTA	40Ω	40Ω—100Ω	Above 500W
DS3-20P7-PQA DS3E-20P7-PFA DS3L-20P7-PFA DS3-20P7-PTA	40Ω	40Ω—100Ω	Above 500W
DS3-21P5-PQA DS3E-21P5-PFA DS3L-21P5-PFA DS3-21P5-PTA	25Ω	25Ω—50Ω	Above 1000W
DS3-22P3-PQA DS3E-22P3-PFA DS3L-22P3-PFA	25Ω	25Ω—50Ω	Above 1000W

DS3-22P3-PTA			
DS3-41P5-PQA DS3E-41P5-PFA DS3L-41P5-PFA DS3-41P5-PTA	55Ω	55Ω—100Ω	Above 1000W
DS3-43P0-PQA DS3E-43P0-PFA DS3L-43P0-PFA DS3-43P0-PTA	55Ω	55Ω—75Ω	Above 1000W
DS3-45P5-PQA DS3L-45P5-PQA	25 Ω	25 Ω —65 Ω	Above 2000W
DS3-47P5-PQA DS3L-47P5-PQA	25 Ω	25 Ω —50 Ω	Above 2000W
DS3-411P0-PQA DS3-415P0-PQA	18 Ω	18 Ω —45 Ω	Above 3000W



1. The temperature will be very high when the regenerative resistor is discharging, please using heat-resistant non-flammable wire. Don't touch the regenerative resistor when wiring.

2. When you choose the regenerative resistor, please make the resistor value close to the min value of recommend value. The resistor power is decided by the actual condition specially the heat.

3-2. DS3E/DS3L-PFA

3-2-1. Main circuit wiring

3-2-1-1. The terminal arrangement

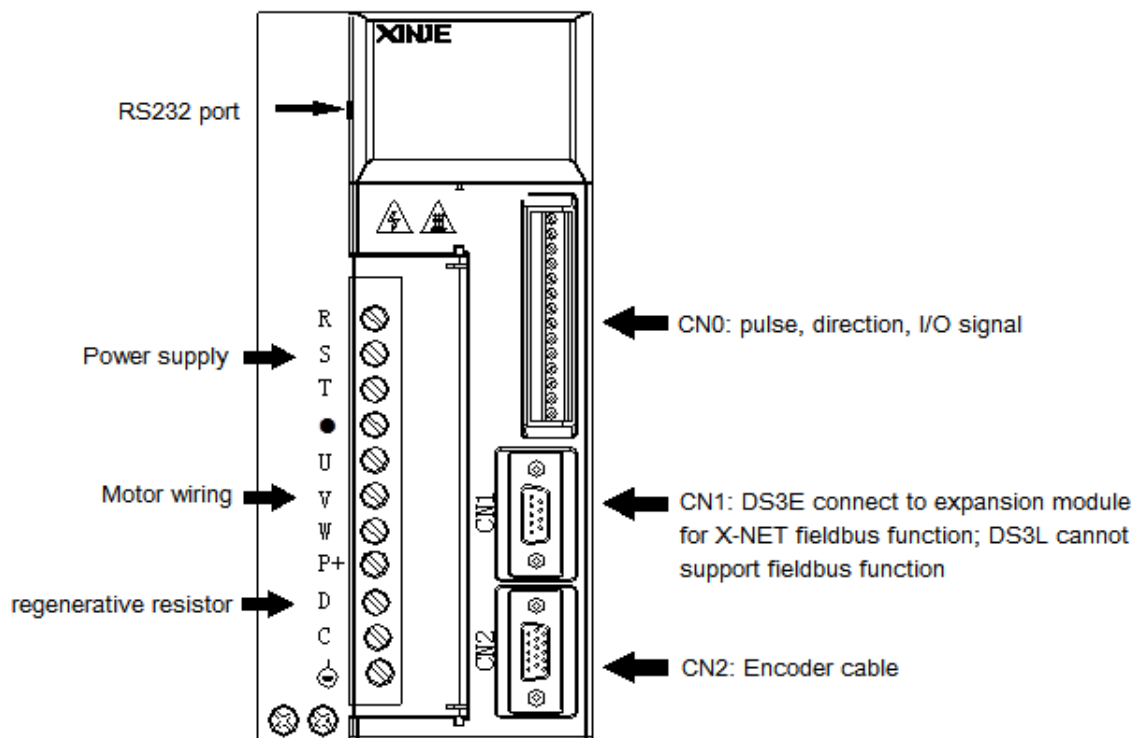

3-2-1-2. Main circuit terminals

	<ul style="list-style-type: none"> ■ DS3E-20P2-PFA, DS3E-20P4-PFA, DS3E-20P7-PFA ■ DS3L-20P2-PFA, DS3L-20P4-PFA, DS3L-20P7-PFA 												
	Terminal	Function	Explanation										
	L/N	Power supply input of main circuit	Single AC 200~240V, 50/60Hz										
	●	Vacant terminal	-										
	U, V, W	Motor terminals	Connect the motor <table border="1" style="margin-left: 20px;"> <thead> <tr> <th>Terminal</th> <th>Color</th> </tr> </thead> <tbody> <tr> <td>U</td> <td>brown</td> </tr> <tr> <td>V</td> <td>black</td> </tr> <tr> <td>W</td> <td>blue</td> </tr> <tr> <td>PE</td> <td>Yellow green</td> </tr> </tbody> </table> <p style="color: red; margin-left: 20px;">Note: the ground wire is on the cooling fin, do not connect to P+ or P-, please check it before power on.</p>	Terminal	Color	U	brown	V	black	W	blue	PE	Yellow green
	Terminal	Color											
U	brown												
V	black												
W	blue												
PE	Yellow green												
P+, D, C	Internal regenerative resistor	Short P+ and D, disconnect P+ and C, set P0-24=0											
	External regenerative resistor	Connect regenerative resistor between P+ and C, disconnect P+ and D, set P0-24=1, P0-25= power value, P0-26= resistor value (see chapter 3-4)											
P+/P-	Bus terminal	Real-time check the bus voltage, please take attention of this terminal											
	<ul style="list-style-type: none"> ■ DS3E-21P5-PFA, DS3E-22P3-PFA, DS3E-41P5-PFA ■ DS3L-21P5-PFA, DS3L-22P3-PFA, DS3L-41P5-PFA 												
	Terminal	Function	Explanation										
	R/S/T	Power supply input of main circuit	DS3E-21P5/22P3-PFA 3 phases AC 200~240V, 50/60Hz DS3E-41P5-PFA 3 phases AC 360~400V, 50/60Hz										
	●	Vacant	-										
	U, V, W	Motor terminals	Connect the motor <table border="1" style="margin-left: 20px;"> <thead> <tr> <th>Terminal</th> <th>Color</th> </tr> </thead> <tbody> <tr> <td>U</td> <td>brown</td> </tr> <tr> <td>V</td> <td>black</td> </tr> <tr> <td>W</td> <td>blue</td> </tr> <tr> <td>PE</td> <td>Yellow green</td> </tr> </tbody> </table> <p style="color: red; margin-left: 20px;">Note: check the ground terminal before power on, not connect to P+, P-!</p>	Terminal	Color	U	brown	V	black	W	blue	PE	Yellow green
	Terminal	Color											
U	brown												
V	black												
W	blue												
PE	Yellow green												
P+, D, C	Internal regenerative resistor	Short P+ and D, disconnect P+ and C, set P0-24=0											
	External regenerative resistor	Connect regenerative resistor between P+ and C, disconnect P+ and D, set P0-24=1, P0-25=power value, P0-26=resistor value (see chapter 3-1-4)											
⊕	Ground	Connect to ground terminal of motor, then connect to the ground											

	<ul style="list-style-type: none"> ■ DS3E-43P0-PFA ■ DS3L-43P0-PFA 																														
	<table border="1"> <thead> <tr> <th>Terminal</th> <th>Function</th> <th>Explanation</th> </tr> </thead> <tbody> <tr> <td>R/S/T</td> <td>Power supply input of main circuit</td> <td>3 phases AC 360~400V, 50/60Hz</td> </tr> <tr> <td>•</td> <td>Vacant</td> <td></td> </tr> <tr> <td>U, V, W</td> <td>Motor terminals</td> <td> Connect the motor <table border="1" style="margin: 5px 0;"> <thead> <tr> <th>Terminal</th> <th>Color</th> </tr> </thead> <tbody> <tr> <td>U</td> <td>brown</td> </tr> <tr> <td>V</td> <td>black</td> </tr> <tr> <td>W</td> <td>blue</td> </tr> <tr> <td>PE</td> <td>Yellow green</td> </tr> </tbody> </table> <p style="color: red; font-size: small;">Note: the ground wire is on the cooling fin, do not connect to P+ or P-, please check it before power on.</p> </td> </tr> <tr> <td rowspan="2">P+, D, C</td> <td>Internal regenerative resistor</td> <td>Short P+ and D, disconnect P+ and C, set P0-24=0</td> </tr> <tr> <td>External regenerative resistor</td> <td>Connect regenerative resistor between P+ and C, disconnect P+ and D, set P0-24=1, P0-25=power value, P0-26=resistor value (see chapter 3-1-4)</td> </tr> <tr> <td>P+/P-</td> <td>Bus terminal</td> <td>Measure the real-time bus voltage, please be careful!</td> </tr> </tbody> </table>	Terminal	Function	Explanation	R/S/T	Power supply input of main circuit	3 phases AC 360~400V, 50/60Hz	•	Vacant		U, V, W	Motor terminals	Connect the motor <table border="1" style="margin: 5px 0;"> <thead> <tr> <th>Terminal</th> <th>Color</th> </tr> </thead> <tbody> <tr> <td>U</td> <td>brown</td> </tr> <tr> <td>V</td> <td>black</td> </tr> <tr> <td>W</td> <td>blue</td> </tr> <tr> <td>PE</td> <td>Yellow green</td> </tr> </tbody> </table> <p style="color: red; font-size: small;">Note: the ground wire is on the cooling fin, do not connect to P+ or P-, please check it before power on.</p>	Terminal	Color	U	brown	V	black	W	blue	PE	Yellow green	P+, D, C	Internal regenerative resistor	Short P+ and D, disconnect P+ and C, set P0-24=0	External regenerative resistor	Connect regenerative resistor between P+ and C, disconnect P+ and D, set P0-24=1, P0-25=power value, P0-26=resistor value (see chapter 3-1-4)	P+/P-	Bus terminal	Measure the real-time bus voltage, please be careful!
	Terminal	Function	Explanation																												
	R/S/T	Power supply input of main circuit	3 phases AC 360~400V, 50/60Hz																												
	•	Vacant																													
	U, V, W	Motor terminals	Connect the motor <table border="1" style="margin: 5px 0;"> <thead> <tr> <th>Terminal</th> <th>Color</th> </tr> </thead> <tbody> <tr> <td>U</td> <td>brown</td> </tr> <tr> <td>V</td> <td>black</td> </tr> <tr> <td>W</td> <td>blue</td> </tr> <tr> <td>PE</td> <td>Yellow green</td> </tr> </tbody> </table> <p style="color: red; font-size: small;">Note: the ground wire is on the cooling fin, do not connect to P+ or P-, please check it before power on.</p>	Terminal	Color	U	brown	V	black	W	blue	PE	Yellow green																		
	Terminal	Color																													
U	brown																														
V	black																														
W	blue																														
PE	Yellow green																														
P+, D, C	Internal regenerative resistor	Short P+ and D, disconnect P+ and C, set P0-24=0																													
	External regenerative resistor	Connect regenerative resistor between P+ and C, disconnect P+ and D, set P0-24=1, P0-25=power value, P0-26=resistor value (see chapter 3-1-4)																													
P+/P-	Bus terminal	Measure the real-time bus voltage, please be careful!																													

3-2-1-3. Winding Terminals on Servo motor

Symbol	40, 60, 80, 90 Series	110, 130, 180 Series
PE	4-yellow green (yellow green)	1-yellow green
U	1-brown (red)	2-brown
V	3-black (blue)	3-black
W	2-blue (yellow)	4-blue
Terminal for brake	1: +24V 2: GND	

3-2-1-4. CN0, CN1, CN2 terminals

CN0	CN1(at drive side)		CN2 (DB15 female port) at drive side
	DB9 male port	DB15 male port	
P- P+5V P+24V D- D+5V D+24V SI1 SI2 SI3 SI4 +24V SO1 SO2 COM			

■ CN0 terminals

No.	Name	Explanation	No.	Name	Explanation
1	P-	Pulse input PUL-	8	SI2	Input 2
2	P+5V	5V difference input	9	SI3	Input 3
3	P+24V	Open collector input	10	SI4	Input 4
4	D-	Direction input DIR-	11	+24V	Input +24V
5	D+5V	5V difference input	12	SO1	Output 1
6	D+24V	Open collector input	13	SO2	Output 2
7	SI1	Input 1	14	COM	Ground of output

■ DS3E series CN1 (DB9) terminals

No.	Name	Explanation	No.	Name	Explanation
1	GND	GND-485	2	A1	RS485+
3	B1	RS485-	4	A2	RS485+
5	B2	RS485-	6	GND	GND-485
7	NC	Reserved	8	NC	Reserved
9	NC	Reserved			

■ DS3L series CN1 (DB15) terminals (DS3L has no frequency division function)

No.	Name	Explanation	No.	Name	Explanation
1	NC	Reserved	2	NC	Reserved
3	NC	Reserved	4	NC	Reserved
5	B-	Encoder output B-	6	A+	Encoder output A+
7	A-	Encoder output A-	8	Z+	Encoder output Z+
9	Z-	Encoder output Z-	10	B+	Encoder output B+
11	NC	Reserved	12	NC	Reserved
13	NC	Reserved	14	NC	Reserved
15	NC	Reserved	-	-	-

Note: The fieldbus module is necessary to connect to CN1 to perform X-NET fieldbus function. The module cannot hot plug. Please use Profibus cable to ensure the communication reliability.

■ CN2 terminals

Drive port	Motor encoder port		Name	Drive port	Motor encoder port		Name
	60, 80, 90 series	110, 130, 180 series			60, 80, 90 series	110, 130, 180 series	
1	9	4	A+	2	4	5	B+
3	7	6	Z+	4	6	10	U+
5	11	12	W+	6	13	7	A-
7	14	8	B-	8	5	9	Z-
9	8	13	U-	10	15	15	W-
11	1	1	Connect to shield layer	12	3	3	GND
13	2	2	5V	14	10	11	V+
15	12	14	V-				

3-2-1-5. Communication port

■ RS-232 communication

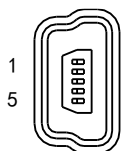
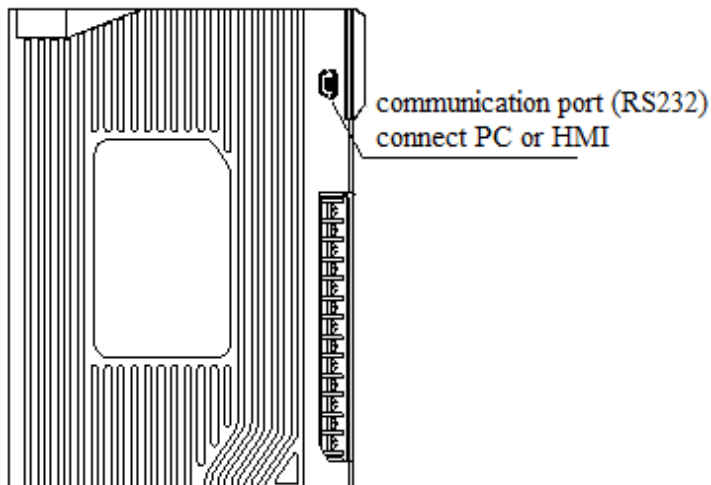

(5-pin port)

Pin no.	Name	Explanation
1	TXD	RS232 send
2	RXD	RS232 receive
3	GND	RS232 ground

Note: please use the cable supplied by XINJE Company

Communication parameters:

RS232 default communication parameters: baud rate 19200bps, data bit 8, stop bit 1, even parity.

Modbus station no.

Parameter	Function	Default setting	Range	Effective time
P7-10	Modbus station no.	1	1~255	Servo OFF

Please set the following parameters through P7-11:

Parameter no.	Function	Default value	Range	Effective time
n.xx□□	Baud rate	06	00~10 00: 300 01: 600 02: 1200 03: 2400 04: 4800 05: 9600 06: 19200 07: 38400 08: 57600 09: 115200 0A: 192000 0B: 256000 0C: 288000 0D: 384000 0E: 512000 0F: 576000 10: 768000	Servo OFF

n.X□XX	Stop bit	2	0: 2 bits, 2: 1 bit	Servo OFF
n.□XXX	Parity bit	2	0~2 0:no parity, 1: odd parity, 2: even parity	Servo OFF
Note: data bit cannot be changed, it is 8 bits.				

■ RS-485 port

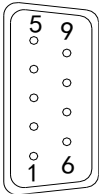
<p>DS3E series</p>  <p>CN1: port definition at drive side</p>	<table border="1" style="margin-left: auto; margin-right: auto;"> <thead> <tr> <th>No.</th> <th>Name</th> </tr> </thead> <tbody> <tr> <td>CN1-2</td> <td>A</td> </tr> <tr> <td>CN1-3</td> <td>B</td> </tr> </tbody> </table> <ol style="list-style-type: none"> 1. The fieldbus module is necessary to connect to CN1 to perform X-NET fieldbus function. The module cannot hot plug. Please use Profibus cable to ensure the communication reliability. 2. For Modbus-RTU communication. <p style="text-align: center;">Note: DS3L cannot support RS485 and fieldbus.</p>	No.	Name	CN1-2	A	CN1-3	B
No.	Name						
CN1-2	A						
CN1-3	B						

Communication parameters:

RS485 default communication parameters: baud rate 19200bps, data bit 8, stop bit 1, even parity, Modbus station no.1.

The Modbus station no. can be set through P7-00:

Parameter	Function	Default value	Range	Effective time
P7-00	Modbus station no.	1	0~255	Servo OFF

The communication parameters can be set through P7-01:

Parameter	Function	Default value	Range	Effective time
n.XX□□	Baud rate	06	00~10 00: 300 01: 600 02: 1200 03: 2400 04: 4800 05: 9600 06: 19200 07: 38400 08: 57600 09: 115200 0A: 192000 0B: 256000 0C: 288000 0D: 384000 0E: 512000 0F: 576000 10: 768000 11: 1M 12: 2M 13: 3M 14: 4M 15: 5M 16: 6M	Servo OFF
n.X□XX	Stop bit	2	0: 2 bits, 2: 1 bit	Servo OFF

n.□xxx	Parity bit	2	0~2 0:no parity, 1: odd parity, 2: even parity	Servo OFF
Note: data bit cannot be changed, it is 8 bits.				

P7-02 RS485 communication protocol setting:

Parameter	Function	Default setting	Range	Effective time
P7-02	RS485 communication protocol	1	1: Modbus Rtu protocol 2: Xnet fieldbus	Servo OFF



1. Support standard Modbus RTU protocol, it is used as Modbus slave device.
2. RS232 port and RS485 port can be used at the same time.

3-2-2. Signal terminals

3-2-2-1. Pulse signal

Command	Choice	Meaning	P-input signal	D-input signal	Chapter
P0-10 xxx□	1	AB phase mode	A phase	B phase	5-3-2
	2	Pulse + direction mode	Pulse	Direction	
Collector open circuit (24V) input positive signal: P+24V/D+24V					
Differential mode (5V) input positive signal: P+5V/D+5V					

The interface circuit of Pulse + direction and CW, CCW, AB phase mode:

DS3E-2□P□-PFA DS3E-4□P□-PFA DS3L-2□P□-PFA DS3L-4□P□-PFA	Open collector (24V)
	<div style="display: flex; justify-content: space-between;"> <div style="width: 45%;"> <p>PLC, SCM, etc</p> </div> <div style="width: 45%;"> <p>servo drive</p> <p>When upper device is open collector output, please use this wiring diagram. Please note: P+5V and D+5V must be vacant.</p> </div> </div> <p>Note: (1) P+24V/P-, D+24V/D- power supply range is 18~25V. smaller than 18V will cause pulse and direction error.</p> <p>(2) Please use tisted shielded pair to avoid interference</p>
DS3E-2□P□-PFA	Differential mode (5V)

DS3E-4□P□-PFA
 DS3L-2□P□-PFA
 DS3L-4□P□-PFA

PLC, SCM, etc

servo drive

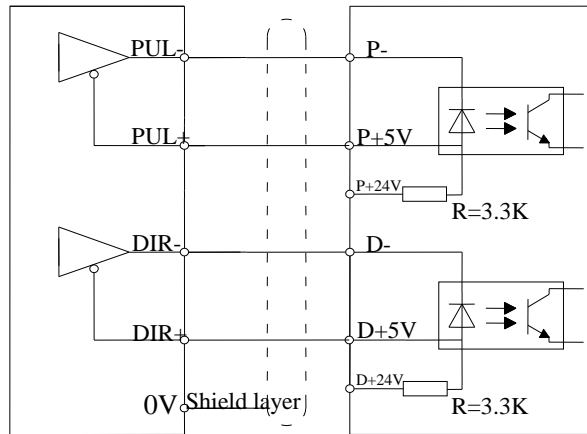

When upper device is 5V differential output, please use this wiring diagram. Please note: P+24V and D+24V must be vacant.

Note: Please use tisted shielded pair to avoid interference



- (1) Servo drive pulse input will be ON at 10mA.
- (2) If the controller is XINJE PLC, pulse output terminal rated current 50mA, 1 channel pulse can connect 5 servo drives. We suggest it cannot over 3 servo drives.

3-2-2-2. SI input signal

Please use relay or open collector transistor to connect. When using relay, please choose micro-current relay. Otherwise, the contact will be not good.

Type	Input terminal	Function	Reference chapter
Digital input	SI1~SI4	Multi-functional input	5-12-1

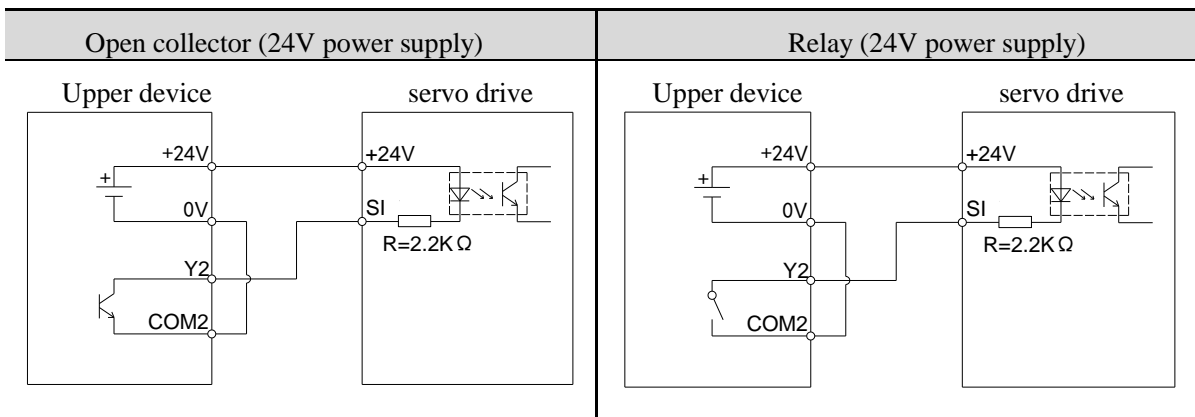

Note: the max allowable voltage and current of open collector output circuit:

Voltage: max DC30V

Current: max DC50mA

3-2-2-3. SO output signal

Type	Output terminal	Function	Reference chapter
Optocoupler output	SO1~SO2	Multi-functional output terminal	5-12-3

Note: please use twisted shielded pair to avoid interference.

Optocoupler type

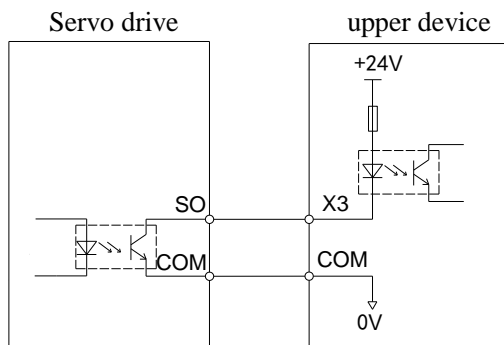

Relay type

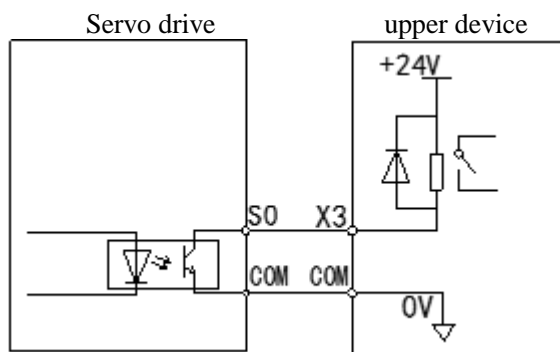

Note: SO output max allowable load current is 400mA. (please check the brake current if the SO controls the brake motor, it needs to use auxiliary relay for current larger than 400mA)

3-2-2-4. Analog input circuit

DS3E/DS3L series servo drive cannot support analog input function.

3-2-2-5. Encoder feedback signal

DS3E series servo drive cannot support encoder feedback output function.

3-2-3. Standard wiring example

The input and output terminal function is out of factory settings in wiring example. The setting can be changed, please see chapter 5-12.

3-2-3-1. Position mode

Refer to chapter 3-1-3 (DS3E series servo drive cannot support encoder feedback output).

3-2-4. Regenerative resistor

Refer to chapter 3-1-4.

3-3. DS3-PTA series

3-3-1. Main circuit wiring

3-3-1-1. The terminal arrangement

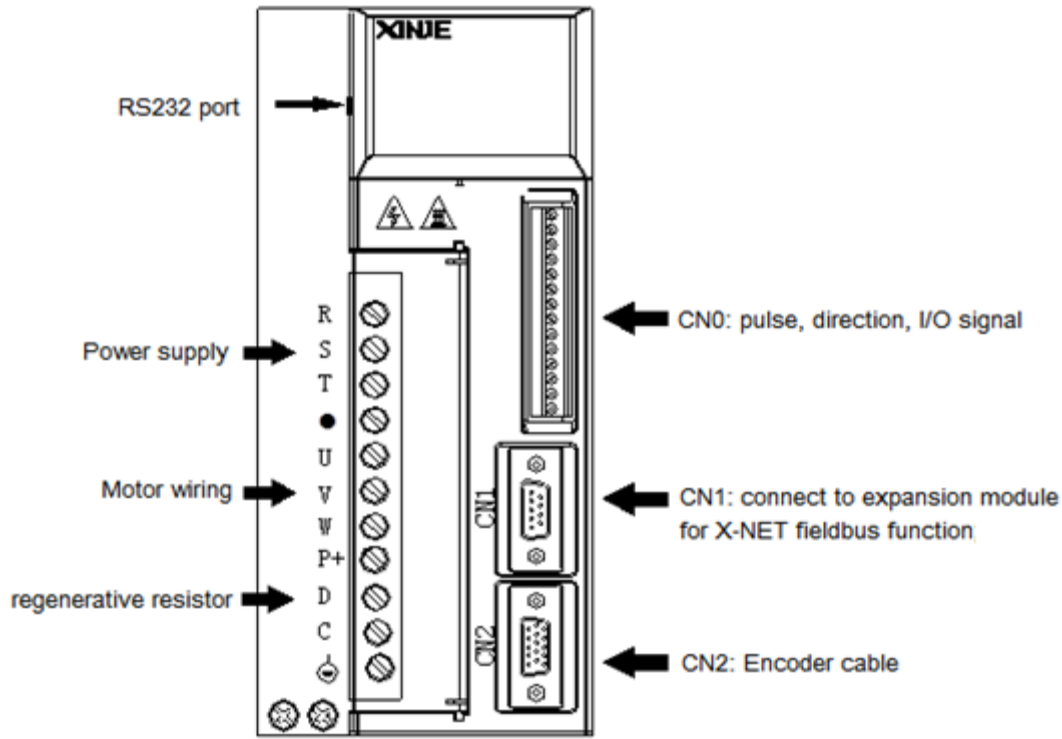

3-3-1-2. Main circuit terminals

		■ DS3-20P2-PNA, DS3-20P4-PNA, DS3-20P7-PTA										
Terminal	Function	Explanation										
L1 L2 L3	Power supply input of main circuit	Single or 3 phase AC 200 ~ 240V, 50/60Hz Note: if using single phase 220V, please connect L1, L3 to the power supply, otherwise it will affect the power-off retentive function.										
U V W												
●	Vacant terminal	-										
U, V, W	Motor terminals	Connect the motor										
			<table border="1"> <thead> <tr> <th>Terminal</th> <th>Color</th> </tr> </thead> <tbody> <tr> <td>U</td> <td>brown</td> </tr> <tr> <td>V</td> <td>black</td> </tr> <tr> <td>W</td> <td>blue</td> </tr> <tr> <td>PE</td> <td>Yellow green</td> </tr> </tbody> </table> <p>Note: the ground wire is on the cooling fin, do not connect to P+ or P-, please check it before power on.</p>	Terminal	Color	U	brown	V	black	W	blue	PE
Terminal	Color											
U	brown											
V	black											
W	blue											
PE	Yellow green											
P+, D, C	Internal regenerative resistor	Short P+ and D, disconnect P+ and C, set P0-24=0										
	External regenerative resistor	Connect regenerative resistor between P+ and C, disconnect P+ and D, set P0-24=1,										

		P0-25= power value, P0-26= resistor value (see chapter 3-1-4)
P+/P-	Bus terminal	Real-time check the bus voltage, please take attention of this terminal

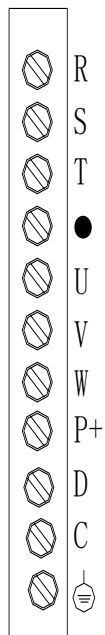

■ DS3-21P5-PTA, DS3-22P3-PTA

Terminal	Function	Explanation										
R/S/T	Power supply input of main circuit	DS3-21P5/22P3-PTA 3 phases AC 200~240V, 50/60Hz Note: if using single phase 220V, please connect power supply to R and T, otherwise it will affect power-off retentive function. DS3-41P5-PTA 3 phases AC 360~400V, 50/60Hz										
•	Vacant	-										
U, V, W	Motor terminals	Connect the motor <table border="1"> <thead> <tr> <th>Terminal</th> <th>Color</th> </tr> </thead> <tbody> <tr> <td>U</td> <td>brown</td> </tr> <tr> <td>V</td> <td>black</td> </tr> <tr> <td>W</td> <td>blue</td> </tr> <tr> <td>PE</td> <td>Yellow green</td> </tr> </tbody> </table>	Terminal	Color	U	brown	V	black	W	blue	PE	Yellow green
Terminal	Color											
U	brown											
V	black											
W	blue											
PE	Yellow green											
P+, D, C	Internal regenerative resistor	Short P+ and D, disconnect P+ and C, set P0-24=0										
	External regenerative resistor	Connect regenerative resistor between P+ and C, disconnect P+ and D, set P0-24=1, P0-25=power value, P0-26=resistor value (see chapter 3-1-4)										
⊕	Ground	Connect to ground terminal of motor, then connect to the ground										

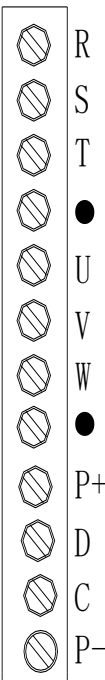

■ DS3-43P0-PTA

Terminal	Function	Explanation										
R/S/T	Power supply input of main circuit	3 phases AC 360~400V, 50/60Hz										
•	Vacant											
U, V, W	Motor terminals	Connect the motor <table border="1"> <thead> <tr> <th>Terminal</th> <th>Color</th> </tr> </thead> <tbody> <tr> <td>U</td> <td>brown</td> </tr> <tr> <td>V</td> <td>black</td> </tr> <tr> <td>W</td> <td>blue</td> </tr> <tr> <td>PE</td> <td>Yellow green</td> </tr> </tbody> </table> Note: the ground wire is on the cooling fin, do not connect to P+ or P-, please check it before power on.	Terminal	Color	U	brown	V	black	W	blue	PE	Yellow green
Terminal	Color											
U	brown											
V	black											
W	blue											
PE	Yellow green											
P+, D, C	Internal regenerative resistor	Short P+ and D, disconnect P+ and C, set P0-24=0										
	External regenerative resistor	Connect regenerative resistor between P+ and C, disconnect P+ and D, set P0-24=1, P0-25=power value, P0-26=resistor value (see chapter 3-1-4)										

	P-	Bus terminal	Real-time check the bus voltage, please take attention of this terminal
--	----	--------------	---

3-3-1-3. Winding Terminals on Servo motor

Symbol	40, 60, 80, 90 Series	110, 130, 180 Series
PE	4-yellow green (yellow green)	1-yellow green
U	1-brown (red)	2-brown
V	3-black (blue)	3-black
W	2-blue (yellow)	4-blue
Terminal for brake	1: +24V 2: GND	

3-3-1-4. CN0, CN1, CN2 terminals

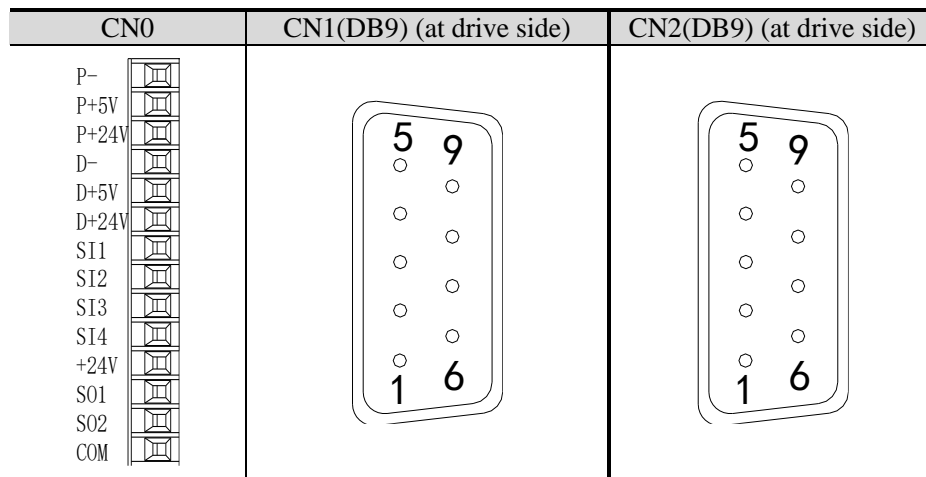

■ CN0 terminals

No.	Name	Explanation	No.	Name	Explanation
1	P-	Pulse input PUL-	8	SI2	Input 2
2	P+5V	5V difference input	9	SI3	Input 3
3	P+24V	Open collector input	10	SI4	Input 4
4	D-	Direction input DIR-	11	+24V	Input +24V
5	D+5V	5V difference input	12	SO1	Output 1
6	D+24V	Open collector input	13	SO2	Output 2
7	SI1	Input 1	14	COM	Ground of output

■ CN1 (DB9) terminals

No.	Name	Explanation	No.	Name	Explanation
1	GND	GND-485	2	A1	RS485+
3	B1	RS485-	4	A2	RS485+
5	B2	RS485-	6	GND	GND-485
7	NC	Reserved	8	NC	Reserved
9	NC	Reserved			

Note: The fieldbus module is necessary to connect to CN1 to perform X-NET fieldbus function. The module cannot hot plug. Please use Profibus cable to ensure the communication reliability.

■ CN2(DB9 male port) terminals

Drive port	Motor encoder interface	Name	Drive port	Motor encoder interface	Name
	60, 80, 90 series			110, 130, 180 series	
1	\	\	1	1	Shield layer
2	\	\	2	\	\
3	3	SD-	3	3	SD-
4	4	SD+	4	4	SD+
5	5	Shield layer	5	\	\
6	6	0V	6	6	0V
7	7	battery-	7	7	battery-
8	8	5V	8	8	5V
9	9	battery+	9	9	battery+

3-3-1-5. Communication port

■ RS-232 communication

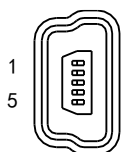
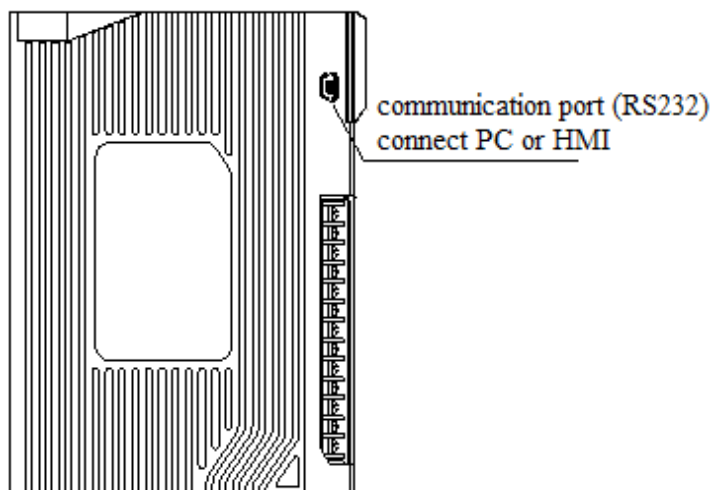

(5-pin port)

Pin no.	Name	Explanation
1	TXD	RS232 send
2	RXD	RS232 receive
3	GND	RS232 ground

Note: please use the cable supplied by XINJE Company

Communication parameters:

RS232 default communication parameters: baud rate 19200bps, data bit 8, stop bit 1, even parity.

Modbus station no.

Parameter	Function	Default setting	Range	Effective time
P7-10	Modbus station no.	1	1~255	Servo OFF

Please set the following parameters through P7-11:

Parameter no.	Function	Default value	Range	Effective time
n.XX□□	Baud rate	06	00~10 00: 300 01: 600 02: 1200 03: 2400 04: 4800 05: 9600 06: 19200 07: 38400 08: 57600 09: 115200 0A: 192000 0B: 256000 0C: 288000 0D: 384000 0E: 512000 0F: 576000 10: 768000	Servo OFF
n.X□XX	Stop bit	2	0: 2 bits, 2: 1 bit	Servo OFF
n.□XXX	Parity bit	2	0~2 0:no parity, 1: odd parity, 2: even parity	Servo OFF

Note: data bit cannot be changed, it is 8 bits.

■ RS-485 port

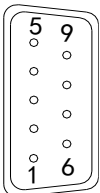
<p>DS3E series</p>  <p>CN1: port definition at drive side</p>	<table border="1"> <thead> <tr> <th>No.</th> <th>Name</th> </tr> </thead> <tbody> <tr> <td>CN1-2</td> <td>A</td> </tr> <tr> <td>CN1-3</td> <td>B</td> </tr> </tbody> </table> <p>CN1 is not functional port, the pin has no meaning. The fieldbus module can connect to CN1 to perform X-NET fieldbus function. The module cannot hot plug. Please use Profibus cable to ensure the communication reliability.</p>	No.	Name	CN1-2	A	CN1-3	B
No.	Name						
CN1-2	A						
CN1-3	B						

Communication parameters:

RS485 default communication parameters: baud rate 19200bps, data bit 8, stop bit 1, even parity, Modbus station no.1.

The Modbus station no. can be set through P7-00:

Parameter	Function	Default value	Range	Effective time
P7-00	Modbus station no.	1	0~255	Servo OFF

The communication parameters can be set through P7-01:

Parameter	Function	Default value	Range	Effective time
n.XX□□	Baud rate	06	00~10 00: 300 01: 600 02: 1200 03: 2400	Servo OFF

			04: 4800 05: 9600 06: 19200 07: 38400 08: 57600 09: 115200 0A: 192000 0B: 256000 0C: 288000 0D: 384000 0E: 512000 0F: 576000 10: 768000 11: 1M 12: 2M 13: 3M 14: 4M 15: 5M 16: 6M	
n.X□XX	Stop bit	2	0: 2 bits, 2: 1 bit	Servo OFF
n.□XXX	Parity bit	2	0~2 0:no parity, 1: odd parity, 2: even parity	Servo OFF
Note: data bit cannot be changed, it is 8 bits.				

P7-02 RS485 communication protocol setting:

Parameter	Function	Default setting	Range	Effective time
P7-02	RS485 communication protocol	1	1: Modbus Rtu protocol 2: Xnet bus	Servo OFF



1. Support standard Modbus RTU protocol, it is used as Modbus slave device.
2. RS232 port and RS485 port can be used at the same time.

3-3-2. Signal terminals

3-3-2-1. Pulse signal

Command	Choice	Meaning	P-input signal	D-input signal	Chapter
P0-10 xxx□	0	CW, CCW double pulse mode	CW	CCW	5-3-2
	1	AB phase mode	A phase	B phase	
	2	Pulse + direction mode	Pulse	Direction	
Collector open circuit (24V) input positive signal: P+24V/D+24V Differential mode (5V) input positive signal: P+5V/D+5V					

The interface circuit of Pulse + direction and CW, CCW, AB phase mode:

<p>DS3-2□P□-PTA DS3-4□P□-PTA</p>	<p style="text-align: center;">Open collector (24V)</p> <div style="display: flex; justify-content: space-between;"> <div style="width: 45%;"> <p>PLC, SCM, etc</p> </div> <div style="width: 45%;"> <p>servo drive</p> <p>When upper device is open collector output, please use this wiring diagram. Please note: P+5V and D+5V must be vacant.</p> </div> </div> <p>Note: (1) P+24V/P-, D+24V/D- power supply range is 18~25V. smaller than 18V will cause pulse and direction error. (2) Please use tisted shielded pair to avoid interference</p>
<p>DS3-2□P□-PTA DS3-4□P□-PTA</p>	<p style="text-align: center;">Differential mode (5V)</p> <div style="display: flex; justify-content: space-between;"> <div style="width: 45%;"> <p>PLC, SCM, etc</p> </div> <div style="width: 45%;"> <p>servo drive</p> <p>When upper device is 5V differential output, please use this wiring diagram. Please note: P+24V and D+24V must be vacant.</p> </div> </div> <p>Note: Please use tisted shielded pair to avoid interference</p>



- (1) Servo drive pulse input will be ON at 10mA.
- (2) If the controller is XINJE PLC, pulse output terminal rated current 50mA, 1 channel pulse can connect 5 servo drives. We suggest it cannot over 3 servo drives.

3-3-2-2. SI input signal

Please use relay or open collector transistor to connect. When using relay, please choose micro-current relay. Otherwise, the contact will be not good.

Type	Input terminal	Function	Reference chapter
Digital input	SI1~SI4	Multi-functional input	5-12-1

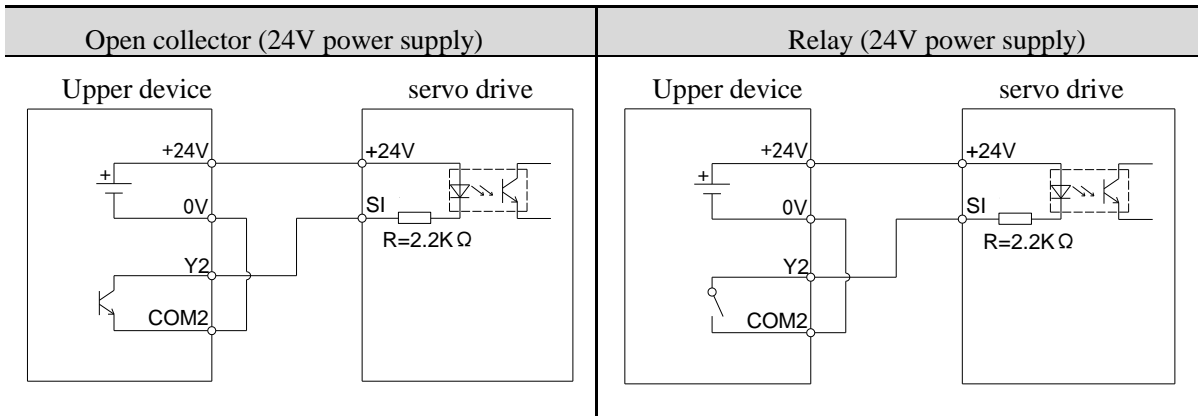

Note: the max allowable voltage and current of open collector output circuit:

Voltage: max DC30V

Current: max DC50mA

3-3-2-3. SO output signal

Type	Output terminal	Function	Reference chapter
Optocoupler output	SO1~SO2	Multi-functional output terminal	5-12-3

Note: please use twisted shielded pair to avoid interference.

Optocoupler type

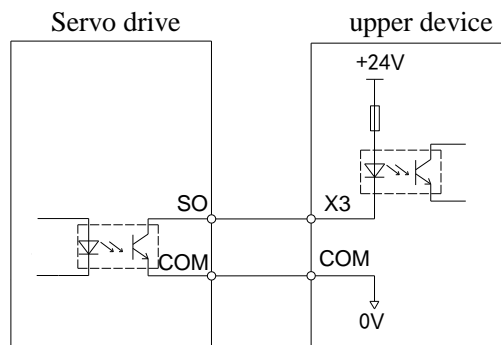

Relay type

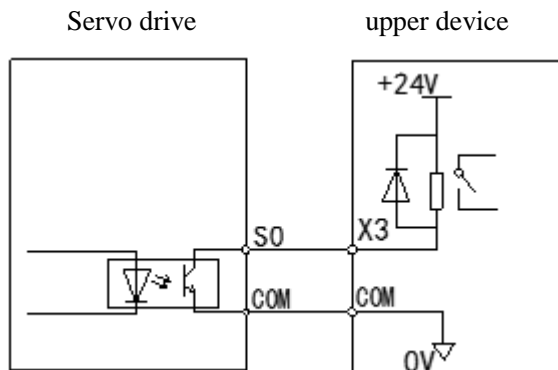

Note: SO output max allowable load current is 400mA. (please check the brake current if the SO controls the brake motor, it needs to use auxiliary relay for current larger than 400mA)

3-3-2-4. Analog input circuit

DS3-PTA series servo drive cannot support analog input function.

3-3-2-5. Encoder feedback signal

DS3-PTA series servo drive cannot support encoder feedback output function.

3-3-3. Standard wiring example

Refer to chapter 3-1-3 (DS3-PTA series servo drive cannot support encoder).

3-3-4. Regenerative resistor

Refer to chapter 3-1-4.

4 Use the operate panel

4-1. Basic Operation

4-1-1. Functions of operate panel

- 5-bit LED: Displaying parameter settings, status or alarm.
- Power LED POWER: The LED is on when the servo drive is powered on.

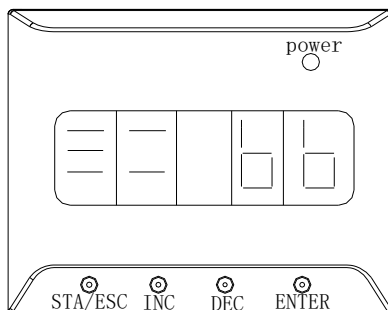

Key Name	Function
STATUS/ESC	Press: Status switch, status return
INC	Press: Increase the value; Press and hold: Increase the value continuously
DEC	Press: Decrease the value; Press and hold: Decrease the value continuously
ENTER	Press: Shift the editing digit; Press and hold: Enter a status, Enter



the operate panel will self-check after power, all the LED will light for 1s.

4-1-2. Basic Mode Switching

The operate panel can display the status, set parameter and run the command by switching the basic mode.

The running status, auxiliary function, parameter setting, and monitoring are the basic modes. The modes switch as the below diagram by pressing STATUS/ESC.

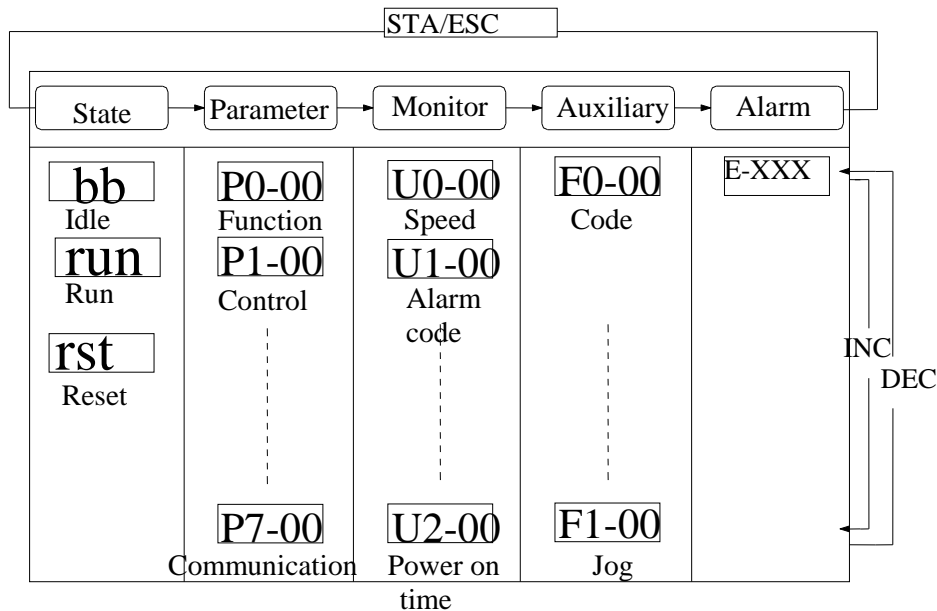

Display mode:

- Monitor Function UX—XX: The first X means group No., the last two X means the member No. in the group.
- Auxiliary Function FX—XX: The first X means group No., the last two X means the member No. in the group.
- Parameter Setting PX—XX: The first X means group No., the last two X means the member No. in the group.
- Alarm E—XXX: XXX means the alarm code.
- State: bb means the servo is in idle state; run means the servo is in running state.

4-2. Running status mode

➤ Speed and Torque Control Mode

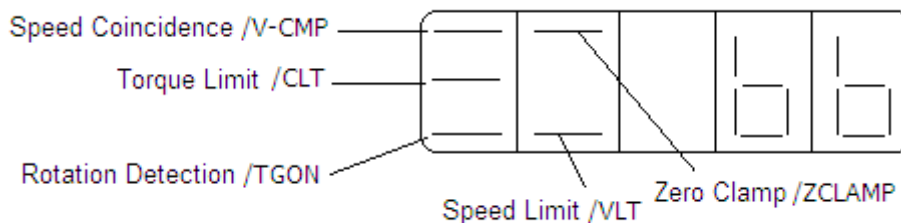

A. Bit contents:

Bit Data	Description
P5-39 Speed Coincidence (/V-CMP)	Light when the motor actual speed and command speed is the same. Speed coincidence signal checking width: P5-04 (unit: rpm)
P5-42 Torque Limit (/CLT)	Light when actual torque exceeds preset value. Forward Torque Limit: P3-28 Reverse Torque Limit: P3-29
P5-40 Rotation Detection (/TGON)	Light when the motor speed exceeds the rotation detection speed. Rotation Detection Speed Level: P5-03(Unit: rpm)
P5-31 Zero Clamp (/ZCLAMP)	Light when zero clamp signal is ON.
P5-43 Speed Limit (/VLT)	Light when actual speed exceeds preset value. Forward speed limit during Torque Control: P3-16, reverse speed limit: P3-17

B. The code contents:

Code	Description
	Standby Servo OFF (motor power OFF)
	Run Servo ON (motor power ON)
	Reset Servo re-power
	Forward Run Prohibited P-OT ON. Please refer to 5-2-4 "Overtravel Limit"
	Reverse Run Prohibited N-OT ON. Please refer to 5-2-4 "Overtravel Limit"

➤ **Position Control Mode**

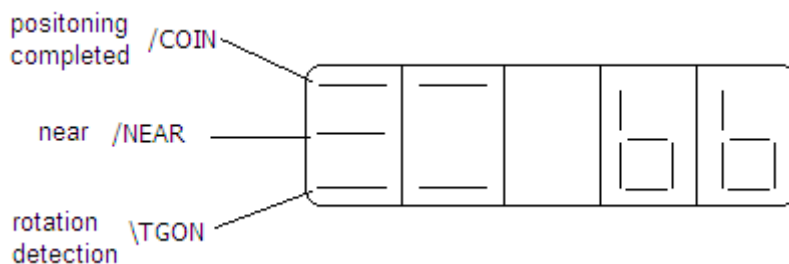

A. The bit contents:

Bit Data	Description
P5-38 Positioning Completed (/COIN)	Light when set position and actual position is the same. Positioning accomplishment width: P5-00 (unit: command pulse)
P5-36 Near (/NEAR)	Light when set position and actual position is the same. Near signal width: P5-06
P5-40 Rotation Detection (/TGON)	Light when the motor speed exceeds the rotation detection speed. Rotation detection speed: P5-03 (unit: rpm)

B. The code contents:

Code	Description
	Standby Servo OFF (motor power OFF)
	Run Servo ON (motor power ON)
	Reset Servo re-power
	Forward Run Prohibited P-OT ON. Please refer to 5-2-4 "Overtravel Limit"
	Reverse Run Prohibited N-OT ON. Please refer to 5-2-4 "Overtravel Limit"

4-3. Monitoring Mode

U0-XX

Number	Monitor Display	Unit
--------	-----------------	------

U0-00	Actual speed of motor		Rpm
U0-01	Input speed command		Rpm
U0-02	Torque command		% of rated
U0-03	Rotate angle (mechenism angle)		0.1 °
U0-04	Rotate angle (electrical angle)		0.1 °
U0-05	Bus voltage		V
U0-06	IPM temperature		0.1°C
U0-07	Torque feedback		% of rated
U0-08	Pulse offset value	(0000~9999)*1	Command pulse
U0-09		(0000~65535)*10000	
U0-10	Encoder feedback value	(0000~9999)*1	encoder pulse
U0-11		(0000~65535)*10000	
U0-12	Pulse value of input command	(0000~9999)*1	Command pulse
U0-13		(0000~65535)*10000	
U0-14	Position feedback	(0000~9999)*1	Command pulse
U0-15		(0000~65535)*10000	
U0-16	Encoder position (Accumulated)	(0000~9999)*1	encoder pulse
U0-17		(0000~65535)*10000	
U0-18	Current, 2-bit decimal/torque current		0.1A
U0-19	Analog input V-REF		0.01V
U0-20	Analog input T-REF		0.01V
U0-21	Input signal status 1		
U0-22	Input signal status 2		
U0-23	Output signal status 1		
U0-24	Output signal status 2		
U0-25	Input pulse frequency	(0000~9999)*1	Hz
U0-26		(0000~9999)*10000	
U0-27	U-phase current sampling zero value related to current value		0.01A
U0-28	V-phase current sampling zero value related to current value		0.01A
U0-29	W-phase current sampling zero value related to current value		0.01A
U0-30	VREF input analog zero value related to digital value		0~4095
U0-31	TREF input analog zero value related to digital value		0~4095
U0-32	Electric zero	(0000~9999)*1	
U0-33		(0000~9999)*10000	
U0-34	Output excitation voltage		% of bus voltage
U0-35	Output torque voltage		% of bus voltage
U0-36	Excitation current (change around 0)		0.01A
U0-37	VREF sampling value		0~4095
U0-38	TREF sampling value		0~4095
U0-39	Reserved		
U0-40	Reserved		
U0-41	Instantaneous output power		1W
U0-42	Average output power		1W
U0-43	Instantaneous thermal power		1W
U0-44	Average thermal power		1W
U0-45	Reserved		
U0-46	Reserved		
U0-47	Reserved		
U0-48	Reserved		
U0-49	Position feedforward		1 command unit
U0-50	Speed feedforward		rpm
U0-51	Torque feedforward		% of rated

U0-52	Instantaneous bus capacitor power	1W
U0-53	Average bus capacitor power	1W
U0-54	Reserved	
U0-55	Instantaneous regenerative braking discharge power	
U0-56	Average regenerative braking discharge power	
U0-57	Absolute encoder present	(0000~9999)*1
U0-58	position feedback	(0000~65535)*10000
		Encoder pulse

U1-XX:

Number	Contents	Unit
U1-00	Current alarm code	
U1-01	Current warning code	
U1-02	U phase current when alarming	0.01A
U1-03	V phase current when alarming	0.01A
U1-04	Bus voltage when alarming	V
U1-05	IGBT temperature when alarming	0.1°C
U1-06	Q axis current (torque current) when alarming	0.1A
U1-07	Excitation current when alarming	A
U1-08	Position offset when alarming	Command pulse
U1-09	Speed value when alarming	rpm
U1-10	The alarm occurred time second (low 16 bits), count from power on	s
U1-11	The alarm occurred time second (high 16 bits), count from power on	s
U1-12	Run error times, count from power on	
U1-13	Warning times, count from power on	
U1-14	History alarm times	
U1-15	History warning times	
U1-16	The second time alarm code recently	
U1-17	The third time alarm code recently	
U1-18	The fourth time alarm code recently	
U1-19	The fifth time alarm code recently	
U1-20	The sixth time alarm code recently	
U1-21	The second time warning code recently	
U1-22	The third time warning code recently	
U1-23	The fourth time warning code recently	
U1-24	The fifth time warning code recently	
U1-25	The sixth time warning code recently	

U2-XX:

Number	Contents	Unit
U2-00	Power on times	
U2-01	Series (low 16 bits)	
U2-02	Series (high 16 bits)	
U2-03	Type	
U2-04	Out of factory date: year	
U2-05	Out of factory date: month	
U2-06	Out of factory date: day	

U2-07	Hardware version	
U2-08	Hardware version	
U2-09	Total run time (from the first time power on)	Hour
U2-10	Total run time (from the first time power on)	Minute
U2-11	Total run time (from the first time power on)	Second
U2-12	This time run time (from this time power on)	Hour
U2-13	This time run time (from this time power on)	Minute
U2-14	This time run time (from this time power on)	Second
U2-15	Average output power (count from the first time enable)	1W
U2-16	Average heating power (count from the first time enable)	1W
U2-17	Average bus capacitor filter power	1W
U2-18	Motor accumulative	(0000~9999)*1
U2-19	circles	(0000~9999)*10000
U2-20	Device serial number: low 16 bits	
U2-21	Device serial number: high 16 bits	
U2-22	Firmware generation date: year	
U2-23	Firmware generation date: month/day	
U2-24	Firmware generation time: hour/minute	

■ U0-21 input signal status

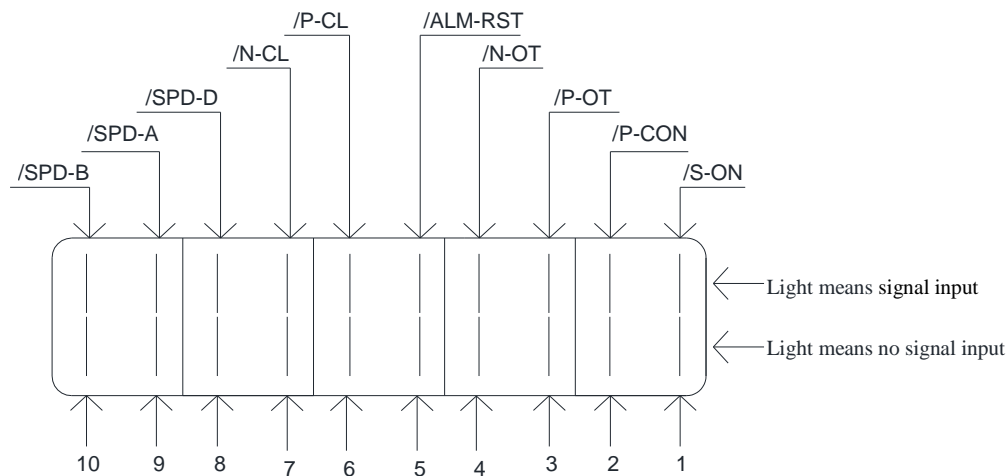

■ U0-21 input signal 1 assignment

Segment code	Explanation	Segment code	Explanation
1	/S-ON servo enable signal	2	/P-CON proportion action command
3	/P-OT forward run prohibited	4	/N-OT reverse run prohibited
5	/ALM-RST alarm reset	6	/P-CL forward side external torque limit
7	/N-CL reverse side external torque limit	8	/SPD-D internal set speed selection
9	/SPD-A internal set speed selection	10	/SPD-B internal set speed selection

Note: read the status through communication, the binary value from right to left are related to /S-ON, /P-CON. 0 means no input, 1 means has input. For example: 0x0001 means /S-ON has input, 0x0201 means /S-ON and /SPD-B has input.

■ U0-22 input signal status

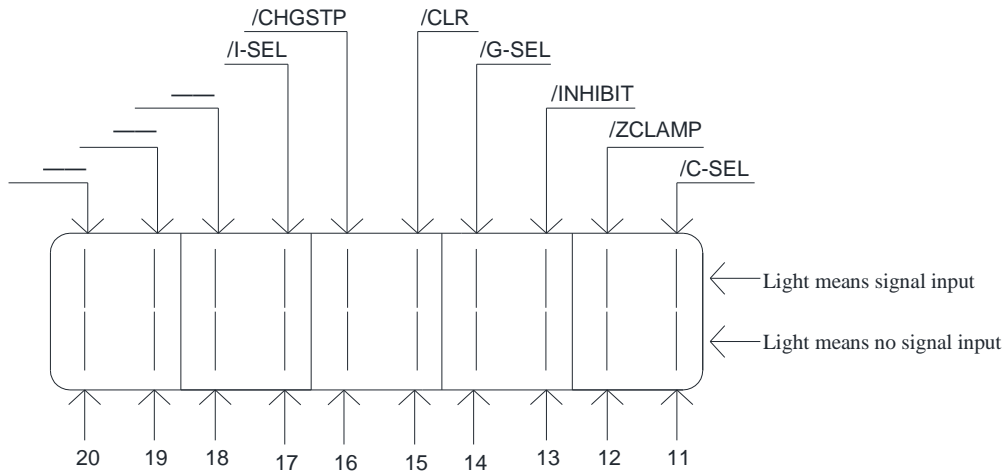

■ U0-22 input signal 2

Segment code	Explanation	Segment code	Explanation
11	/C-SEL control mode	12	/ZCLAMP zero clamp
13	/INHIBIT command pulse prohibited	14	/G-SEL gain switch
15	/CLR pulse clear	16	/CHGSTP change step
17	/I-SEL inertia switch	18	—
19	—	20	—

Note: read the status through communication, the binary value from right to left are related to /C-SEL, /ZCLAMP. 0 means no input, 1 means has input. For example: 0x0001 means /C-SEL has input, 0x0041 means /C-SEL and /I-SEL has input.



“—” is reserved bit, it is always 0.

■ U0-23 output signal status

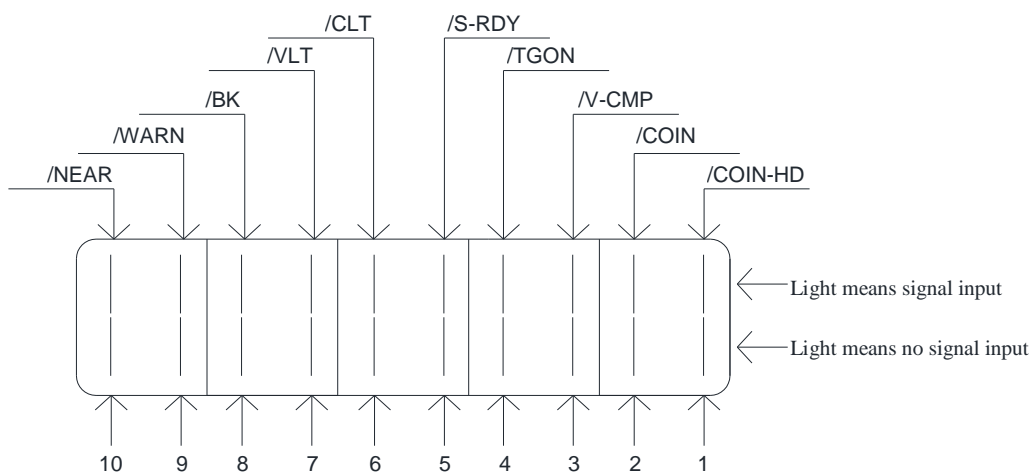

■ U0-23 output signal 1 assignment

Segment code	Explanation	Segment code	Explanation
1	Positioning complete maintain (/COIN_HD)	2	Positioning end (/COIN)
3	Same speed detection (/V-CMP)	4	Rotate detection (/TGON)

5	Ready (/S-RDY)	6	Torque limit (/CLT)
7	Speed limit detection (/VLT)	8	Brake lock (/BK)
9	Warn (/WARN)	10	Output near (/NEAR)

Note: read the status through communication, the binary value from right to left are related to /COIN_HD, /COIN. 0 means no output, 1 means has output. For example: 0x0001 means /COIN_HD has output, 0x0201 means /COIN_HD and /NEAR has output.

■ U0-24 output signal status

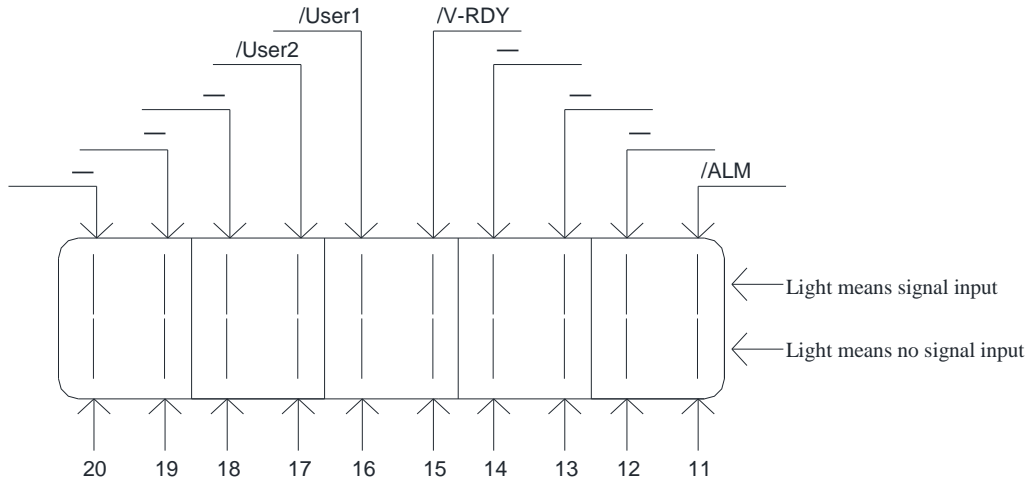

■ U0-24 output signal 2 assignment

Segment code	Explanation	Segment code	Explanation
11	Alarm (/ALM)	12	—
13	—	14	—
15	Speed reach (/V-RDY)	16	Self-defined output 1
17	Self-defined output 2	18	—
19	—	20	—

Note: read the status through communication, the binary value from right to left are related to /ALM, “—”. 0 means no output, 1 means has output. For example: 0x0001 means /ALM has output, 0x0041 means /ALM and self-defined output 2 has output.



“—” is reserved bit, it is always 0.

4-4. Auxiliary Function

Group No.	Content
F0-**	Clean the alarm, back to out of factory settings, clean the offset
F1-**	Jog run, test run, zero, enable

4-4-1. F0-XX

Function No.	Description
F0-00	Clean the alarm
F0-01	Back to out of factory settings
F0-02	Clean the offset

1. Clean the alarm
Set F0-00=1 to reset the alarm. When the alarm occurred, please find out the alarm reasons then clean the alarm.

2. Back to out of factory settings
Set F0-01=1, then press ENTER. No need to re-power the servo drive.

3. Clean the offset
Set F0-02=1 to clean the offset.

4-4-2. F1-XX

Function code	Explanation
F1-00	Jog run
F1-01	Test run
F1-02	Current sampling zero
F1-03	Vref zero
F1-04	Tref zero
F1-05	Software enable

1. Jog (F1-00)

Make sure that the motor shaft is not connected to the machine before jogging!

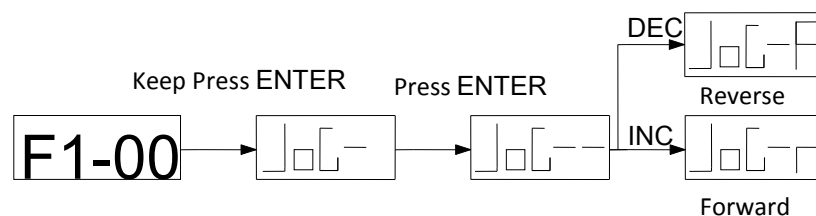

When the servo is in jog run mode, gain and other parameters will join the process. Please adjust the parameters according to the jog run status.

P3-18	JOG speed					
	Unit	Default	Setting range	Suitable mode	Change	Effective
	1Rpm	100	0~1000	JOG	Servo OFF	Immediately

2. Test run (F1-01)

Make sure that the motor shaft is not connected to the machine before test run!

When servo drive is connected with non-original encoder line or power line, test run must be run first to ensure that the encoder line or power line is connected correctly.

Test run can detect the connection of power line and encoder feedback. Please operate the servo as the following steps. If the motor shaft jitter or servo alarm, please cut off the power at once then check the wiring.

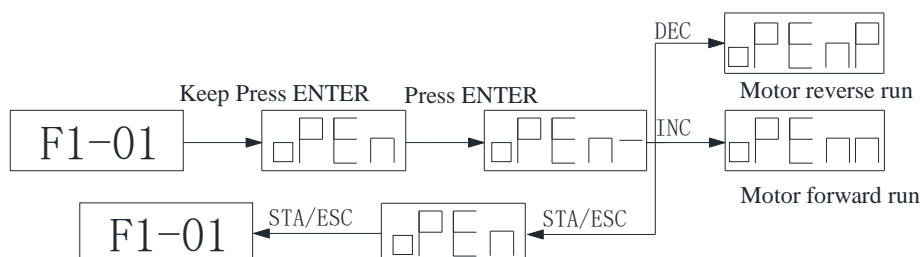

3. Current sampling zero (F1-02)

After the servo drive updated to latest software version, or the motor does not revolve smoothly for long time, the current offset auto-adjustment is recommended.



Press STATUS/ESC to exit.

4. Vref zero (F1-03)

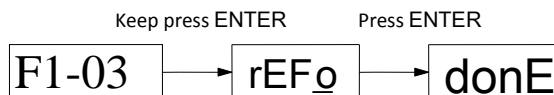

Press STATUS/ESC key to exit.

5. Tref zero (F1-04)

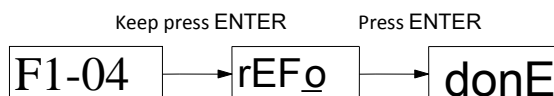

Press STATUS/ESC key to exit.

6. Forced Servo enables (F1-05)

Parameter	Signal name	Set	Meaning	Modify	Effective
P0-03	Enable mode	0	Not enable	Servo OFF	At once
		1 (default)	I/O enable /S-ON		
		2	Software enable (F1-05 or communication)		
		3	Bus enable (the model support movement bus)		
P0-03=2 F1-05 = 0: cancel the enable, return to bb status. F1-05 = 1: forced enable, servo is in RUN status.					

4-5. Alarm (E-XXX)

The alarm code will show when there is error in the drive. Set F0-00=1 to reset the alarm. If the servo is OFF caused by alarm, it is no need to reset the alarm.

Note: please find out the alarm reason before reset the alarm.

4-6. Example

The example below shows how to change parameter P3-09 from 2000 to 3000.

1. Press the STATUS/ESC key to select the parameter setting mode.

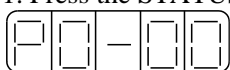

2. At this time the second LED is blinking, and press INC or DEC key to set the group No. to 3. Press ENTER key to confirm.

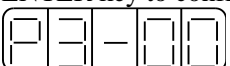

3. At this time the last LED is blinking, and press INC or DEC key to set the member No. to 9. Press and hold ENTER key to confirm.

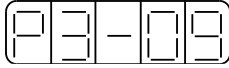

4. At this time the panel displays the value in P3-09, and the last decimal “0” is blinking. Press ENTER to left shift the blinking decimal. Press INC, DEC or ENTER key to modify the value to 3000, and press and hold ENTER to confirm.



The parameter in P3-09 in changed from 2000 to 3000.
Repeat steps 2 to 4 to change the parameter again.
5. Press STATUS/ESC key to return.



when the parameters are over the setting range, the drive will show E-021 alarm.

4-7. Change the motor code

One servo drive can match several servo motors with same power level. Before using the servo system, please make sure the motor code on the servo motor label is the same to P0-33.



Motor label

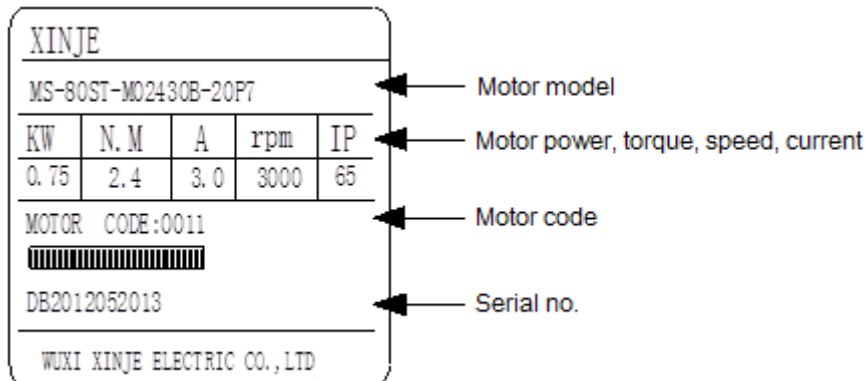

If the servo motor code set error, the servo will show E-310 alarm. Please clean the alarm through F0-00 then set the motor code again.

5 Run the servo system

5-1. Control mode selection

PQA servo mode 1 and 2 can be switched to each other via /C-SEL signal.

Parameter		Control mode	Reference
P0-01	1	Torque control (internal setting) Control the output torque of servo motor via operating panel or communication.	5-8
	2	Torque control (analog voltage command) ---- only DS3-PQA support Control the output torque of servo motor via analog voltage command. It is mostly used to close-loop torque control with upper device, such as tension control. (If servo drive doesn't have analog input port, it cannot use this mode.)	5-7
	3	Speed control (internal speed setting) Use /SPD-D, /SPD-A, /SPD-B to select the speed which is set in the servo drive. The servo drive can set 3 speeds.	5-5
	4	Speed control (analog voltage command) ---- only DS3-PQA support Control the speed of servo motor via analog voltage command. It is mostly used to close-loop speed control with upper device. (If servo drive doesn't have analog input port, it cannot use this mode.)	5-4
	5	Position control (internal position command) ---- only DS3E/DS3L support Control the position via internal position command; it can set pulse quantity and torque. Note: hardware version need v3.2.1 and higher	
	6 (default setting)	Position control (external pulse command) Control the position of servo motor via pulse command. Control the position via pulse quantity; control the speed via pulse frequency.	5-3
	7	Speed control (pulse frequency command) Control the speed of servo motor via pulse frequency, but not control the position.	5-6
	10	X-NET fieldbus position mode ---- only DS3E support	5-9
P0-02 mode2	Same to mode 1	The servo will enter mode 2 when /C-SEL signal is effective.	

5-2. Basic function setting

Parameter	Name	Reference
P0-03	Enable mode	5-2-1
P5-20	Servo ON setting /S-ON	
P0-05	Switch the motor rotate direction	5-2-2
P0-27	Servo OFF stop mode	5-2-3
P0-28	Motor overtravel stop mode	
P0-29	Alarm stop mode	
P0-30	Stop time out time	
P3-32	Brake torque	
P5-22	Forward run ban /P-OT	5-2-4
P5-23	Reverse run ban /N-OT	
P5-44	Power loss brake /BK	5-2-5

5-2-1. Servo ON setting

When servo ON signal is ineffective, the servo motor cannot run.

Parameter	Signal name	Setting	Meaning	Modify	Effective
P0-03	Enable mode	0	Not enable	Servo OFF	At once
		1 (default)	I/O enable /S-ON		
		2	Software enable (F1-05 or communication)		
		3	Bus enable (the model support bus movement)		

Parameter	Signal	Setting	Explanation	Range
P5-20	/S-ON	n.0001 (default value)	When SII is ON, servo motor powers on and enables to run.	0001~0015
		n.0010	Always effective, no need to wiring.	

/S-ON signal can be set to other input via parameter P5-20.



the input terminal assigned by function parameters cannot be duplicated. Please refer to chapter 5-12-1.

5-2-2. Switch the motor rotate direction

Change the motor rotate direction without changing the motor wiring. The standard forward rotate direction is “CCW rotate” look at the load side.

“Reverse mode” will change the motor rotate direction.

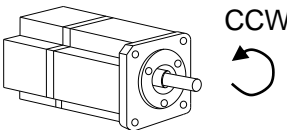
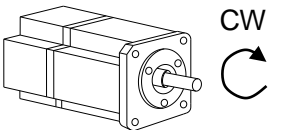
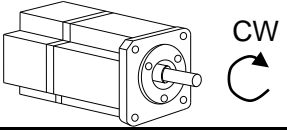
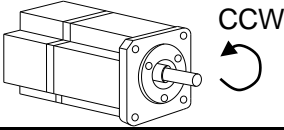
Mode	Forward rotate	Reverse rotate
Standard setting: CCW is forward rotate		
Reverse mode: CW is forward rotate		

■ Set the rotate direction

Parameter	Setting	Explanation
P0-05	0 (default setting)	Standard setting (CCW is forward running)
	1	Reverse mode (CW is forward running)

5-2-3. Stop mode

Set the stop mode when servo is OFF or alarm.

Parameter	Function	Setting value	Default value
P0-27	Servo OFF stop mode	0 or 2	0
P0-29	Alarm	0 or 2	0

0: Inertia run stop, keep inertia movement after stop
 2: deceleration stop, keep inertia movement after stop

P0-30	Stop time out time			
	Unit	Default value	Range	Suitable mode
	0.1ms	20000	0~65535	All the modes
P3-32	Brake torque			
	Unit	Default value	Range	Suitable mode
	0.1% of rated torque	100	0~300	All the modes



1. the stop mode is 0. the motor will inertia stop until the speed is less than P5-03 (rotate detection speed) then change to free stop when servo OFF or alarm. At the same time, the servo will count the inertia stop time. If the time is larger than P0-30 but the motor speed is not smaller than P5-03, servo will free stop and show stop time out alarm.
2. the stop mode is 2. The motor will produce a brake torque P3-32 and deceleration stop until the speed is less than P5-03 then change to free stop when servo OFF or alarm. At the same time, servo will count the inertia stop time. If the time is larger than P0-30, but P5-03 is not smaller than P5-03, servo will free stop and show stop time out alarm.

Stop mode when overtravel

Parameter	Function	Range	Default value
P0-28	Motor stop mode when overtravel	0~3	2

P0-28	Meaning
0	Deceleration stop, the torque is 0 in overtravel direction after stop, receive command.
1	Inertia stop, the torque is 0 in overtravel direction after stop, receive command.
2	Deceleration stop, not receive command in overtravel direction after stop.
3	Alarm (E-260)



1. The brake torque is P3-32 when deceleration stop and stop time out time is effective for overtravel process.
2. there is position offset pulse when the motor stop by overtravel signal in position control mode. The position offset can be cleaned by inputting the signal /CLR. If the servo still can receive the pulse, the pulse will accumulate until the servo alarm.

5-2-4. Overtravel Limit (P-OT & N-OT)

(1) Use the overtravel signal

Please connect P-OT and N-OT to the limit switch. Make sure to wiring as the following diagram when linear driving to avoid machine damage.

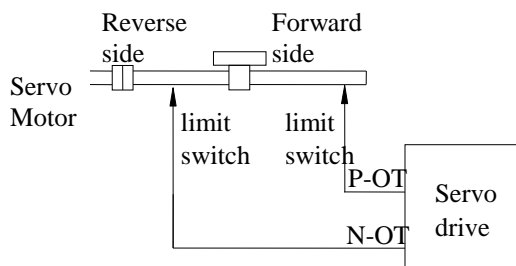

(2) Set the overtravel signal

Parameter	Signal	Setting	Meaning	Modify
P5-22	/P-OT	n.0003 (default)	SI3=ON, prohibit the forward running	Range: 0000-0015

		n.0013	SI3=ON, allow the forward running	
P5-23	/N-OT	n.0004 (default)	SI4=ON, prohibit the reverse running	Range: 0000-0015
		n.0014	SI4=ON, allow the reverse running	

Note:

1. /P-OT, /N-OT can be changed to other terminal input via parameter P5-22 and P5-23.
2. The input terminals function cannot be the same. Please refer to chapter 5-12-1.

5-2-5. Power-off Brake (BK)

It is used when servo drive controls the vertical shaft. The function of power-off brake is the moveable part will not shift when servo is OFF.

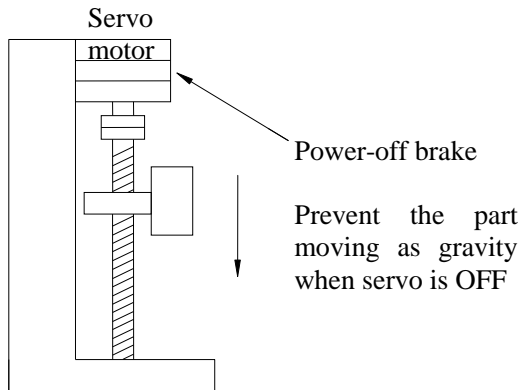

The brake built into the MS series servo motor with brakes is a de-energization brake, which is used only to hold and cannot be used for braking.

1. Wiring Example

The ON/OFF circuit of brake includes sequence output signal /BK and brake power. The following diagram shows a standard wiring example.

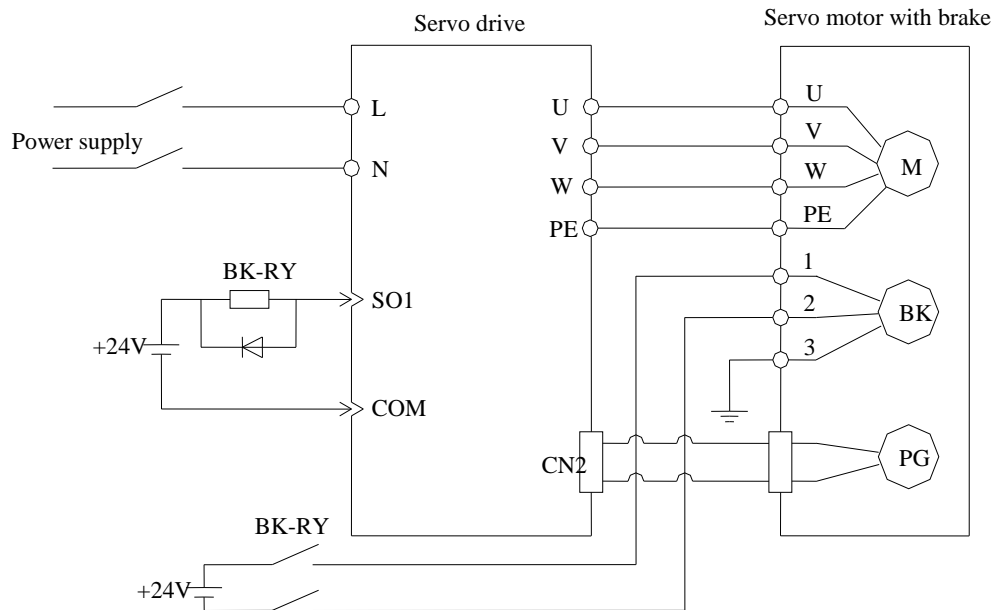

Note: (1) the working voltage of brake is DC 24V.

(2) In the above diagram, BK signal output from SO1, please set P5-44 to n.0011.

2. Brake signal

Parameter	Signal	Type	Default	Explanation	Modify
P5-44	/BK	Output	n.0000	Need to distribute	Range 0000-0013

/BK signal can output from output terminal via setting parameter P5-44.
When set P5-44=0011, it means output from SO1 terminal.

3. The switch time between BK signal and SON signal

If the machine moves slightly due to gravity because of the brake has action delay time. Please adjust the time as below parameter.

P5-07	Servo OFF delay time (brake command)					
	Unit	Default	Range	Suitable mode	Modify	Effective
	1ms	0	0~65535	All the modes	Servo OFF	Immediately

P5-07 Meaning: delay the time P5-07 to release the brake when the enable is ON.

When the enable is OFF and the signal is true, lock the brake and delay the time P5-07 then close the enable.



this setting is rotation detection TGON invalid time when motor stop.

The following diagram is the brake control output signal /BK and servo SON signal act time when using the servo motor with brake.

Before outputting /BK to release the brake, servo already power on; after not output /BK and brake is ON, servo is OFF.

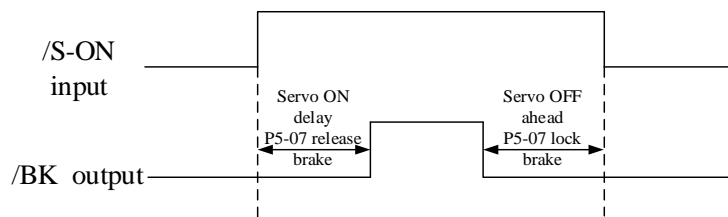

4. Brake ON parameter (When servo motor is rotating)

The motor will power OFF when alarm occurs. The machine will move as gravity until the brake action.

Set below parameters in order to use brake when motor speed decreases to setting value or waiting time ends.

P5-08	Brake command output speed					
	Unit	Default	Range	Suitable mode	Modify	Effective
	rpm	30	0~10000	All the modes	Any	Immediately
P5-09	Brake command waiting time					
	Unit	Default	Range	Suitable mode	Modify	Effective
	1ms	500	0~1000	All the modes	Servo OFF	Immediately

Set the brake time when servo OFF caused by /S-ON signal or alarm.

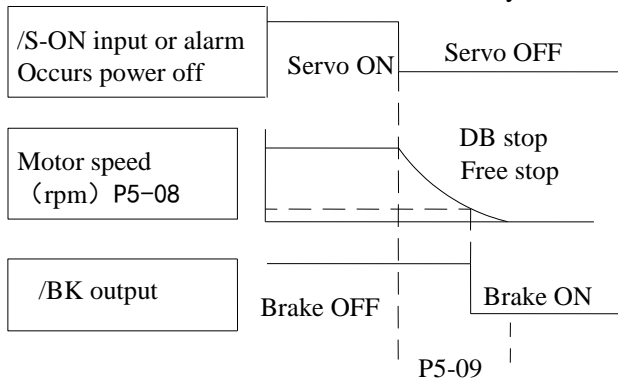

The brake is used to protect the position. The brake must be effective at suitable time when servo motor stop. Users can adjust the parameters according to the machine action.

The /BK signal from ON to OFF under either of the following conditions:

1. Motor speed drops below the value of P5-08 after servo OFF.
2. over the time of P5-09 after servo OFF.

5-2-6. Alarm output

Parameter	Signal	Default	Meaning	Modify
P5-47	Alarm output	n.0002 (default)	SO2 and COM pass through when servo alarm, output the alarm signal	Range: 0000-0013 Distribute the signal to output terminal through P5-47. P5-47=0001, it outputs from SO1.
		n.0012	SO2 and COM cut off when servo alarm	



- (1) Servo unit is forced OFF when alarm. The motor will move with external force. If the motor needs to hold the position, please choose motor with power loss brake and use /BK signal. Please refer to chapter 5-2-5.
- (2) The output terminals distributed by function parameters cannot be same. Please refer to chapter 5-12-3.

5-2-7. Anti-block run alarm

Anti-block run alarm: when the motor speed is lower than P0-75 (unit is 1rpm), and the time of duration reaches P0-74 (unit is second), if the motor present output torque U-02 is over P3-28 internal forward torque limit and P3-29 internal reverse torque limit, the servo will show E-165 block overtime error (when P0-74/75 is set to 0, it will not detect this alarm).

Solution:

1. Monitor U0-02 motor torque, check if P3-28 and P3-29 is suitable.
2. Check mechanical structure.

Note: for servo drive version U2-23 is 1224, the motor block time is P0-70 (unit is second), motor block speed is P0-71 (unit is 1rpm).

5-3. Position mode (external pulse command)

Parameter		
Parameter	Name	Reference chapter
P0-01	Control mode selection	5-3-1
P0-09	Pulse command positive direction	5-3-2
P0-10	Pulse command form	
P0-11	Motor pulse per rotation*1	5-3-3
P0-12	Motor pulse per rotation*10000	
P0-13	Electronic gear ratio (numerator)	
P0-14	Electronic gear ratio (denominator)	
P5-20	Servo ON signal /S-ON	5-2-1

Other available parameters			
Key word	Parameter	Name	Reference
Command filter	P1-24	Position command filter type	5-3-4
	P1-25	Position command filter time constant	
Clean offset pulse	P5-34	Clean the offset pulse /CLR	5-3-5
Positioning finish	P5-00	Positioning finish width	5-3-6
	P5-01	Positioning finish detection mode	
	P5-02	Positioning finish hold time	
	P5-37	Positioning finish hold /COIN-HD	
	P5-38	Positioning finish signal output /COIN	
Positioning near	P5-46	Positioning near signal output /NEAR	5-3-7
	P5-06	Positioning near signal output width	
Prohibit Pulse	P5-32	Command pulse prohibit /INHIBIT	5-3-8
Offset pulse	P0-23	Pulse offset limit value	5-3-9

limit value			
-------------	--	--	--

5-3-1. External position mode

Parameter	Setting value	Meaning	Modify	Effective
P0-01	6	Position control (external pulse)	Servo OFF	Immediately
Function: control the position by the external pulse command				

5-3-2. Pulse command and pulse form

1. Pulse command direction

P0-09	Pulse command positive direction					
	Unit	Default setting	Range	Suitable mode	Change	Effective
	—	0	0~1	6, 7	Servo OFF	At once

P0-09 will change the count direction of servo which control the motor rotation direction. If motor rotation direction is not same to expected direction in position mode, please set this parameter.

2. Pulse command form selectoin

Parameter	Set value	Command form	Suitable mode	Change	Effective
P0-10 xxx□	0	CW, CCW mode (DS3E/DS3L cannot support CW, CCW mode)	6, 7	Servo OFF	At once
	1	AB phase			
	2	Pulse + direction (default)			

Parameter	Set value	Command form	Suitable mode	Change	Effective
P0-10 xx□x	0	Pulse signal falling edge effective (default)	6, 7	Servo OFF	At once
	1	Pulse signal rising edge effective			

3. Command pulse explanation

P0-10 xx□x	P0-10 xxx□	Forward run	Reverse run
0	0: CW/CC W		
	1: AB	<p>A-phase ahead B-phase 90°</p>	<p>B-phase ahead A-phase 90°</p>

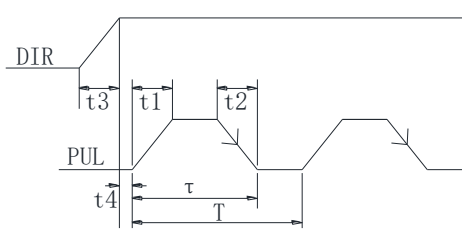
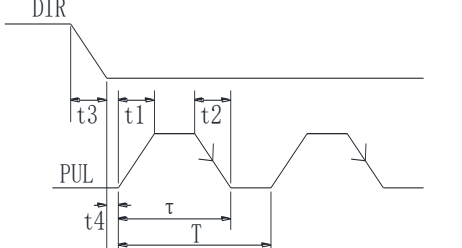
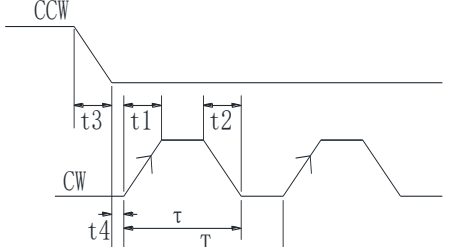
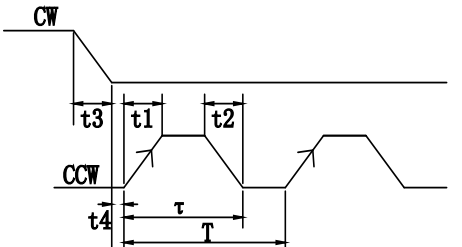
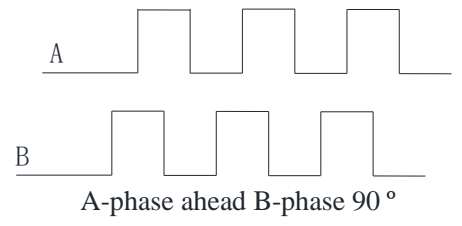
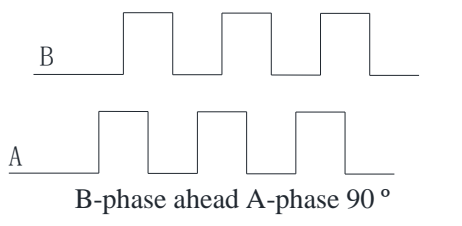
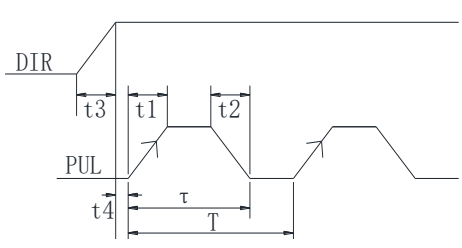
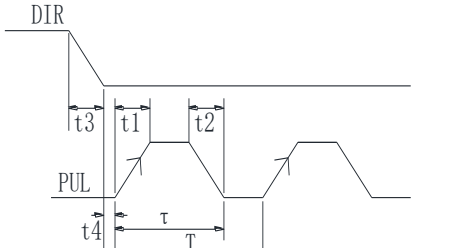
	2: P+D		
1	0: CW/CCW		
	1: AB		
	2: P+D		
<p>Electric specification</p> <p>$t1, t2 \leq 0.1 \mu s$ $t3 \leq 0.1 \mu s$</p> <p>$t4 > 3 \mu s$ $\tau \geq 2.5 \mu s$ $100\tau/T = 40\% \sim 60\%$</p>			

5-3-3. Electronic gear ratio

P0-11	Pulse per rotation $\times 1$					
	Unit	Default value	Range	Suitable mode	Change	Effective
	p	0	0~9999	6	Any	At once
P0-12	Pulse per rotation $\times 10000$					
	Unit	Default value	Range	Suitable mode	Change	Effective
	P	0	0~9999	6	Any	At once
P0-13	Electronic gear ratio (numerator)					
	Unit	Default value	Range	Suitable mode	Change	Effective
	—	1	1~65535	6	Any	At once
P0-14	Electronic gear ratio (denominator)					
	Unit	Default value	Range	Suitable mode	Change	Effective
	—	1	1~65535	6	Any	At once

Note: P0-11~P0-14 are parameters about electronic gear ratio. P0-11 and P0-12 are a group, P0-13 and P0-14 are a group. The priority of P0-11 and P0-12 is higher than P0-13 and P0-14. P0-13 and P0-14

are effective when P0-11 and P0-12 are zero.

The electronic gear ratio functions:

1. Set the command pulse per rotation to ensure the motor speed meet the requirements. For example, the PLC max output pulse frequency is 200KHz. If the electronic gear ratio is not changed, motor needs 10000 pulses per rotation, the motor max speed is 1200rpm. If the electronic gear ratio is 2:1 or the pulses per rotation is 5000, the motor speed can up to 2400rpm.

Example: electronic gear ratio is 1:1 or pulses per rotation is 10000, PLC max output pulse frequency is 200KHz.

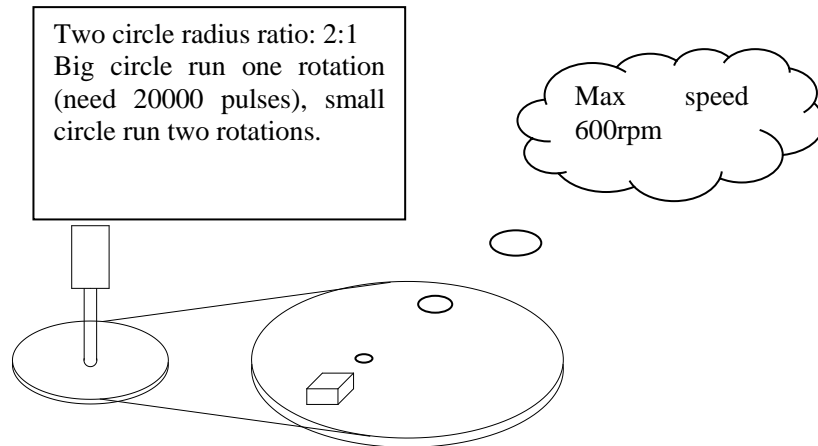

Electronic gear ratio is 2:1 or pulses per rotation is 5000, PLC max output pulse frequency is 200KHz.

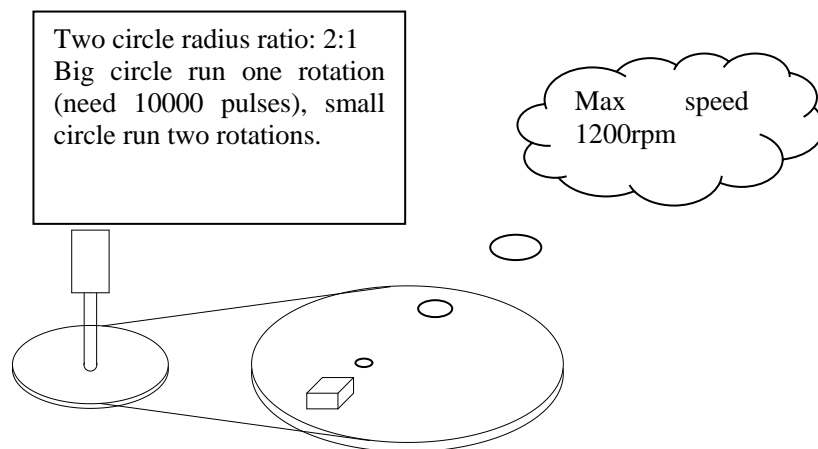

2. Set the actual length per command pulse for precise positioning. For example: the object moves 1um per command pulse. The command pulses of load rotating one circle = $6\text{mm} / 1\mu\text{m} = 6000$. In the case of deceleration ratio is 1:1, set pulse per rotation P0-11=6000, P0-12=0. Then if the PLC outputs 6000 pulses, the object will move 6mm.

Not use electronic gear ratio

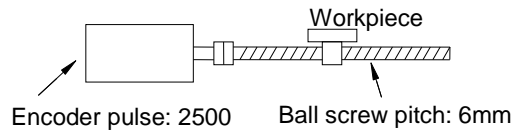

1 rotation is 10000 pulses
 Workpiece moves 6mm per rotation, so the length per pulse is $6\text{mm}/10000 = 0.6\mu\text{m}$.
 The workpiece moves 10mm, so it needs $10\text{mm}/0.6\mu\text{m} = 16666.6666$ pulses. The decimal will be discarded for actual pulse sending.

Use electronic gear

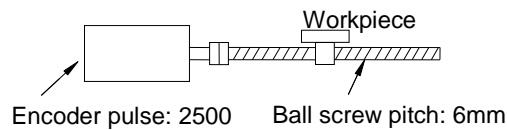

After setting electronic gear ratio, 1 rotation is 6000 pulses
 Workpiece moves 6mm per rotation, so the length per pulse is $6\text{mm}/6000 = 1\mu\text{m}$.
 The workpiece moves 10mm, it needs $10\text{mm}/1\mu\text{m} = 10000$ pulses. It will not produce decimal and error.

Calculate the electronic gear ratio (B/A) using the following steps:

Step	Content	Explanation
1	Confirm the machine specification	Confirm the deceleration ratio, ball screw distance, pulley diameter
2	Confirm the encoder pulse	Confirm the servo motor encoder accuracy
3	Set the command unit	Set the actual distance or angle corresponding to 1 pulse of the controller
4	Calculate the command pulses the load shaft rotates 1 circle	Calculate the command pulses per rotation f based on the command unit
5	Calculate the pulses per rotation (P0-11/P0-12)	For example, the mechanical reduction ratio of motor shaft and load shaft is m/n (servo motor run m circles while load shaft run n circles), $P0-11/P0-12 = (f \times m)/n$
6	Calculate the electronic gear ratio (P0-13/P0-14)	For example, the mechanical reduction ratio of motor shaft and load shaft is m/n (servo motor run m circles while load shaft run n circles), $P0-13 = \text{encoder accuracy} \times 4 \times m$ $P0-14 = f \times n$

Note:

1. Pulses per rotation and electronic gear ratio can limit the command pulses of motor rotate 1 circle. The priority of pulses per rotation is higher than electronic gear ratio. Only when pulses per rotation is 0, the electronic gear ratio will be effective. If the pulses per rotation is fractional, it is better to use electronic gear ratio.
2. When P0-13 and P0-14 is over the range, please use the integer in the range from the reduction of the decimal number.
3. The motor encoder accuracy is 2500P/R.
4. The command unit is not machine accuracy. Refine the command unit based on machine accuracy can improve the servo positioning precision. For example: in the application of screw, the machine precision can up to 0.01mm, so the command unit 0.01mm is more accurate than 0.1mm.

2. Example of setting the electronic gear

The example for different loads:

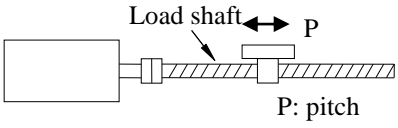
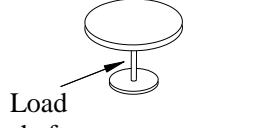
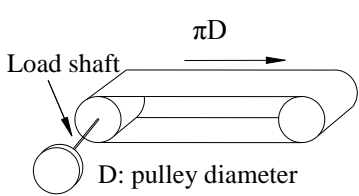
Step	Ball screw	Round table	Belt + pulley
	 <p>Load shaft \leftrightarrow P P: pitch $1 \text{ rotate} = \frac{P}{\text{command unit}}$</p>	 <p>Load shaft $1 \text{ rotate} = \frac{360^\circ}{\text{command unit}}$</p>	 <p>Load shaft \rightarrow πD D: pulley diameter $1 \text{ rotate} = \frac{\pi D}{\text{command unit}}$</p>
1	Ball screw pitch: 6mm Machine deceleration ratio: 1/1	1-circle rotate angle: 360° Deceleration ratio: 3/1	Pulley diameter: 100mm Deceleration ratio: 2/1
2	2500P/R	2500P/R	2500P/R
3	1 command unit: 0.001mm	1 command unit: 0.1°	1 command unit: 0.02mm
4	$6\text{mm}/0.001\text{mm} = 6000$	$360/0.1 = 3600$	$314\text{mm}/0.02\text{mm} = 15700$
5	P0-11=6000 P0-12=0	P0-11=3600 \times 1/3=1200 P0-12=0	P0-11=15700 \times 1/2=7850 P0-12=0
6	$\frac{B}{A} = \frac{2500 \times 4}{6000} \times \frac{1}{1}$	$\frac{B}{A} = \frac{2500 \times 4}{3600} \times \frac{3}{1}$	$\frac{B}{A} = \frac{2500 \times 4}{15700} \times \frac{2}{1}$
7	P0-13=10000 P0-14=6000 Reduction of the fraction P0-13=5 P0-14=3	P0-13=30000 P0-14=3600 Reduction of the fraction P0-13=25 P0-14=3	P0-13=20000 P0-14=15700 Reduction of the fraction P0-13=25 P0-14=3

5-3-4. Position command filter

P1-24	Position command filter					
	Default value	Range	Suitable mode	Meaning	Change	Effective
	0	0-1	6, 10	Filter certain frequency command pulse	Servo OFF	At once

P1-24 setting	Contents
0	First-order inertia filter
1	Smoothing filter

Filter time: filter time constant or set as the following parameter

We suggest to use smoothing filter, the stop and startup will smooth when the instruction has no acceleration and deceleration.

P1-25	Position command filter time					
	Unit	Default	Range	Suitable mode	Change	Effective
	0.1ms	0	0~65535	6, 10	Any	At once

First-order inertia filter diagram:

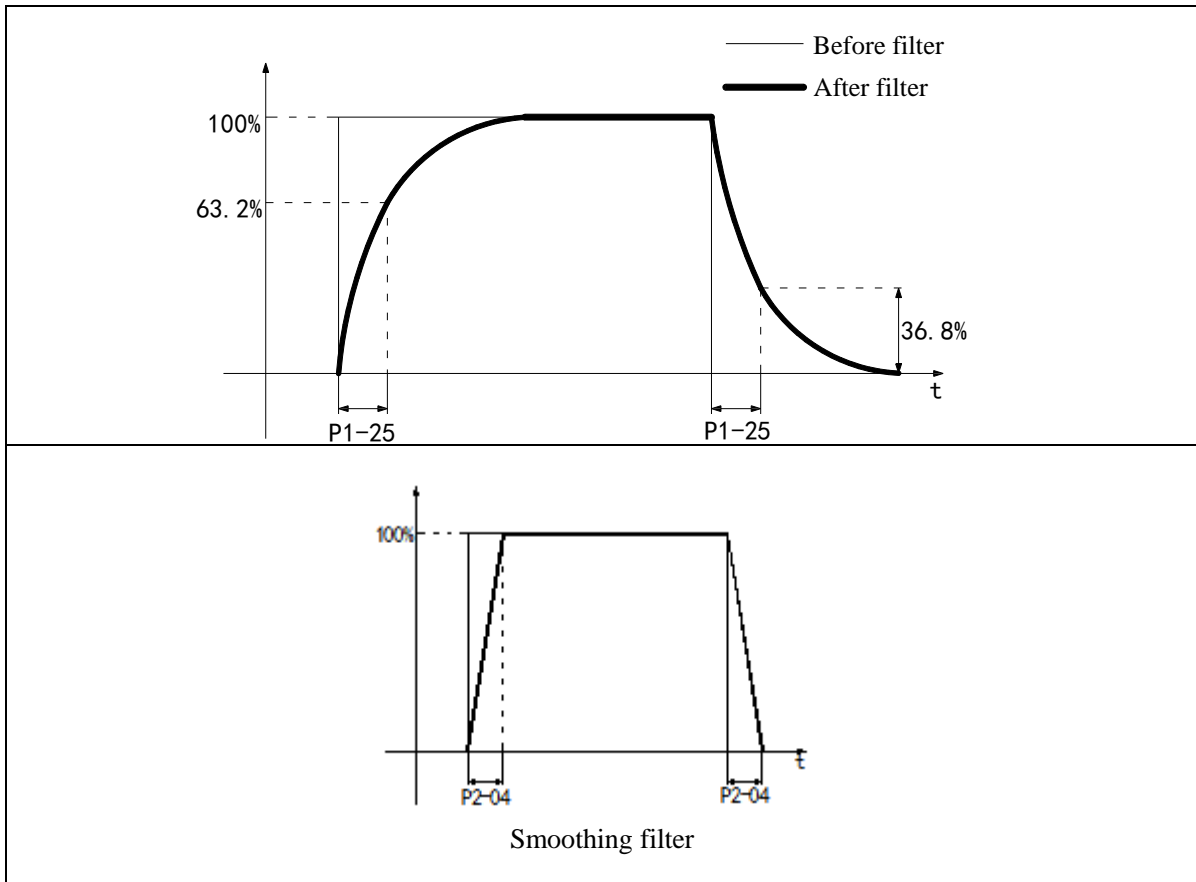

5-3-5. Pulse deviation clear (/CLR)

Pulse deviation: the difference between command pulse of controller (such as PLC) and feedback pulse of servo in position mode. Its unit is 1 reference unit; it is related to the command unit of electronic gear ratio.

Parameter	Signal	Default	Meaning	Suitable mode	Modify
P5-34	/CLR	n.0000	Pulse deviation (U-08) clear	6	Range: 0000-0015. Distribute to output terminal through P5-34. When it set to 0001, output the signal from S11.



The input terminal distributed by function parameter cannot be same. Please refer to chapter 5-12-1.

5-3-6. Positioning complete (/COIN, /COIN_HD)

Use the signal when the controller needs to confirm the completion of positioning.

Parameter	Signal	Type	Default setting	Suitable mode	Meaning	Modify	Effective
P5-37	/COIN-HD	Output	n.0000	6	After COIN signal keeps the time of P5-02, output COIN-HD	any	At once

Range 0000-0013, distribute to output terminal through P5-37. When set P5-37=0001, it means output signal from SO1.

Parameter	Signal	Default	Suitable mode	Meaning	Modify	Effective
P5-38	/COIN	n.0001 (default)	6	Output positioning complete signal from SO1	Any	At once
		n.0011		SO1 and COM cut off when positioning complete		
Range: 0000-0013, distribute to output terminal through P5-38. When it set to 0002, it means output from SO2.						



The output terminal distributed by function parameter cannot be same. Please refer to chapter 5-12-3.

P5-00	Width of positioning complete					
	Unit	Default	Range	Suitable mode	Modify	Effective
	1 command unit	7	0~65535	6	Servo OFF	Immediately
Function: when the pulse deviation value is lower than P5-00, output /COIN signal. Monitor the pulse deviation value via U0-08.						

P5-01	Positioning complete detection mode					
	Default setting	Range	Suitable mode	Meaning	Change	Effective
	0	0~3	6	Set the positioning complete detection mode	Servo OFF	At once
P5-02	Positioning complete hold time					
	Unit	Default setting	Range	Suitable mode	Meaning	Change
	ms	0	0~65535	6	COIN signal hold for the time of P5-02 then output signal COIN-HD	Servo OFF

P5-01	Content	Diagram
0	Output COIN signal when difference absolute value below P5-00	<p>The diagram illustrates the timing of the /COIN signal. It shows three signals over time: /S-ON, U-08 Pulse difference, and /COIN. /S-ON transitions from 0 to 1. U-08 Pulse difference is a trapezoidal pulse. /COIN is a pulse that occurs when the pulse difference is within a range defined by P5-00. The /COIN signal is high (1) when the pulse difference is between -P5-00 and P5-00, and low (0) otherwise.</p>

1	Output COIN signal when the difference below P5-00 after the command end	<p>The diagram shows four signals over time. The top signal, $/S-ON$, is a step function that transitions from 0 to 1 at the start of the pulse command and remains at 1. The second signal, $U-08$ Pulse difference, is a trapezoidal pulse that starts at 0, rises to a peak, and then falls back to 0. A horizontal dashed line labeled $P5-00$ is drawn across the pulse, indicating a threshold level. The third signal, $\Delta U-12$ Pulse command, is a trapezoidal pulse that starts at 0, rises to a peak, and then falls back to 0. The bottom signal, $/COIN$, is a square pulse that transitions from 0 to 1 at the start of the pulse command and returns to 0 at the end of the pulse command. Vertical dashed lines indicate the start and end of the pulse command.</p>
2	output COIN signal when the command end and motor speed below P5-03(rotation detection speed), pulse difference below P5-00	<p>The diagram shows five signals over time. The top signal, $/S-ON$, is a step function that transitions from 0 to 1 at the start of the pulse command and remains at 1. The second signal, $U-08$ Pulse difference, is a trapezoidal pulse that starts at 0, rises to a peak, and then falls back to 0. A horizontal dashed line labeled $P5-00$ is drawn across the pulse, indicating a threshold level. The third signal, $\Delta U-12$ Pulse command, is a trapezoidal pulse that starts at 0, rises to a peak, and then falls back to 0. The fourth signal, $U-00$ Actual speed, is a trapezoidal pulse that starts at 0, rises to a peak, and then falls back to 0. A horizontal dashed line is drawn across the pulse, indicating a threshold level. The bottom signal, $/COIN$, is a square pulse that transitions from 0 to 1 at the start of the pulse command and returns to 0 at the end of the pulse command. Vertical dashed lines indicate the start and end of the pulse command.</p>

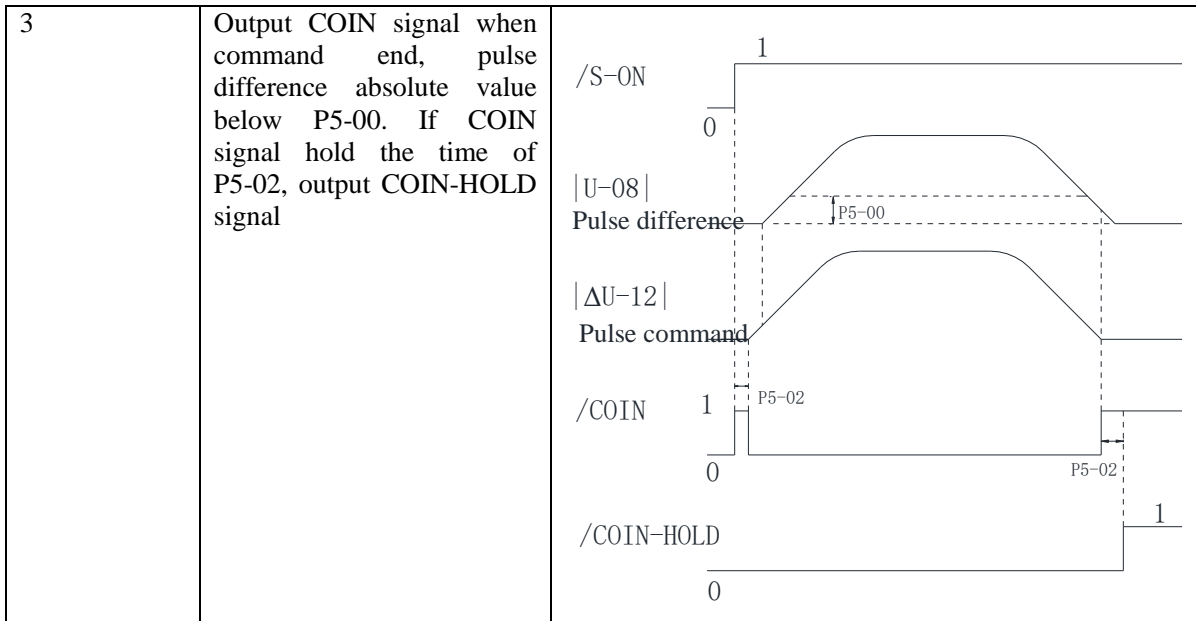

5-3-7. Positioning near (/NEAR)

Positioning near signal means the servo motor is near the positioning complete. It prompts the device to prepare the next operation.

Parameter	Signal	Default	Suitable mode	Meaning	Modify
P5-46	/NEAR	n.0000	6	Servo motor near the position complete signal	Range: 0000-0013, distribute to output terminal via P5-46. When it set to 0001, it means output from SO1.

Note: /NEAR can be output from terminal by setting P5-46, please see chapter 5-12-3.

P5-06	Width of positioning near signal					
	Unit	Default	Range	Suitable mode	Modify	Effective
	1 command unit	50	0~65535	6	Servo OFF	Immediately

Function: when the pulse difference signal is lower than P5-06, output /NEAR signal. Set the parameter wider than positioning complete signal. Monitor the pulse difference value via U-08.

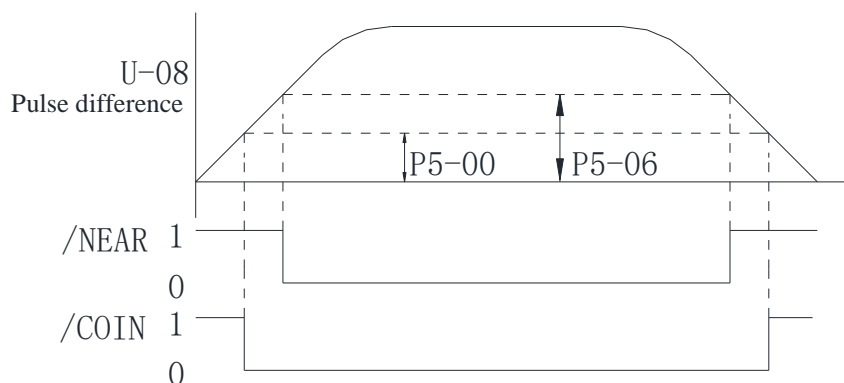

5-3-8. Command pulse prohibition (/INHIBIT)

To stop the command pulse input in position control mode. When /INHIBIT signal is ON, the command pulse stop counting.

Input signal setting:

Parameter	Signal	Default	Suitable mode	Modify	Effective	Modify
P5-32	/INHIBIT	n.0000	6	Any	At once	Range: 0000-0015. When it set to 0001, it means input from SO1.

Note: /INHIBIT can be input from input terminal by setting P5-32. Please refer to chapter 5-12-1

5-3-9. Position pulse difference

When the pulse difference over the limit value in position control mode, servo will alarm. This limit value is pulse difference limit.

P0-23	Pulse difference limit					
	Unit	Default value	Range	Suitable mode	Change	Effective
	256 commands	50000	0~65535	6	Any	At once

When the P0-23=0, it will now detect the pulse difference value.

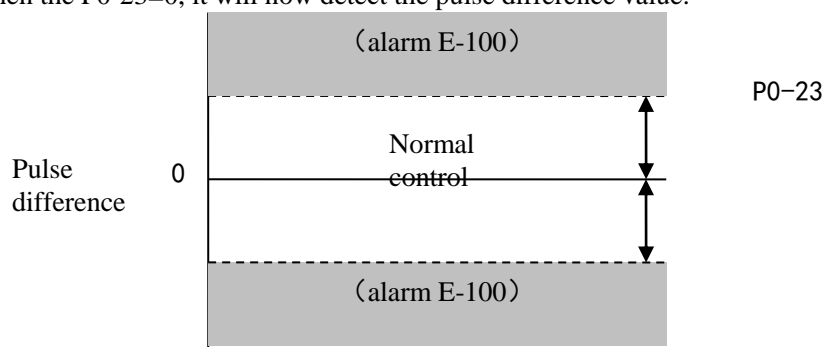

5-4. Speed control (analog voltage command) (Only for DS3-PQA)

Basic parameters		
Parameter	Name	Reference
P0-01	Select the control mode	5-4-1
P3-00	V-REF distribution	5-4-2
P3-01	Rated speed of the corresponding analog voltage	
P3-02	Analog voltage speed filter	
P3-03	Speed command input dead zone voltage	
P3-14	Forward direction max speed command limit	
P3-15	Reverse direction max speed command limit	
P5-20	Servo ON signal /S-ON	5-2-1

Other parameters			
Key words	Parameter	Name	Reference
Zero drift	F1-03	Analog voltage speed command offset	5-4-3

adjustment		auto-adjustment	
Proportion action	P5-21	/P-CON	5-4-4
Zero clamp	P5-31	Zero clamp /ZCLAMP	5-4-5
	P3-12	Zero clamp mode	
	P3-13	Zero clamp speed	
Speed coincidence checking	P5-39	/V-CMP speed coincidence checking	5-4-6
	P5-04	Coincidence speed signal checking width/V-CMP	
Torque limit	P3-28	Forward torque limit	5-4-7
	P3-29	Reverse torque limit	
	P3-23	T-REF distribution	
	P3-30	Forward external torque limit	
	P3-31	Reverse external torque limit	
	P5-25	Forward external torque limit /P-CL	
	P5-26	Reverse external torque limit /N-CL	
	P5-42	Output when torque reaches limit value /CLT	
Soft start	P3-09	Soft start acceleration time	5-4-8
	P3-10	Soft start deceleration time	
Filter	P1-22	Speed command filter mode	5-4-9
	P1-23	Speed command filter time constant	
Speed reach detection	P5-51	Speed reach output /V-RDY	5-4-10
	P5-05	Reach detection speed	
Alarm speed	P3-21	Forward alarm speed	5-4-11
	P3-22	Reverse alarm speed	
/SPD-D direction selection	P5-17	Change the direction	5-5-3

5-4-1. Control mode selection

Parameter	Set value	Meaning	Modify	Effective
P0-01	4	Analog voltage command speed control	Servo OFF	Immediately
Function: control the speed by the signal (analog voltage command) input from V-REF terminal Note:direction switching: positive or negative voltage, SPD-D (P5-27).				

5-4-2. Analog value of rated speed

P3-00	Name	Set	Meaning	Suitable mode	Change	Effective
	V-REF function distribution	0	V-REF input as speed command	4	Servo OFF	At once
P3-01	Analog value of rated speed					
	Unit	Default setting	Range	Suitable mode	Change	Effective
	0.01V	10000	150~30000	1, 2, 4	Servo OFF	At once
Function: the speed command voltage (V-REF) to run the servo motor at rated speed. Such as: P3-01=5000 means the motor run at rated speed when analog input voltage = 5.00V P3-01=8000 means the motor run at rated speed when analog input voltage = 8.00V. Note: (1) Analog voltage command used for speed limit input without polarity. Whether it is positive voltage or negative voltage all take absolute value. This absolute value is fit for forward and reverse direction. (2) the max allowable voltage of analog input signal is $\pm 10V$, please do not use the motor over $\pm 10V$.						
P3-02	analog voltage speed filter					

	Unit	Default setting	Range	Suitable mode	Change	Effective
	0.01ms	0	0~10000	1, 2, 4	Any	At once
Analog command wiring diagram please refer to chapter 3-2-3						
P3-04	Analog speed direction switching	0	0~1	1, 2, 4	Any	At once

Speed command limit

P3-14	Forward max speed command limit					
	Unit	Default setting	Range	Suitable mode	Change	Effective
	1rpm	Motor rated	0~10000	All the modes	Servo OFF	At once
P3-15	Reverse max speed command limit					
	Unit	Default setting	Range	Suitable mode	Change	Effective
	1rpm	Motor rated	0~10000	All the modes	Servo OFF	At once
Note: P3-14 and P3-15 are effective in all the modes.						

5-4-3. Speed command difference auto-adjustment (F1-03)

When the servo is in analog voltage speed mode, even if the command voltage is 0V, motor will run at very low speed. The micro-motion will happen when the command voltage micro-offset (mV) of host controller or external circuit occurs. Auto-adjust the command offset by operate panel of servo.

Take away the analog signal from servo CN1 port in servo bb state (not enabled), then do the following steps:

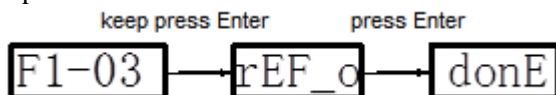

Press STATUS/ESC to exit this function.

Note:

1. The present analog voltage is 0V, please follow the above steps to calibrate, so 0V is 0rpm, motor will reverse run below 0V, motor will forward run above 0V. If the present analog voltage is 5V, and follow the above steps to calibrate, so 5V is 0rpm, motor will reverse run below 5V, motor will forward run above 5V.
2. If there is still micro-motion after calibrating, please increase P3-03(set to 5 means the dead area voltage is 0.005V) or use zero-clamp.

5-4-4. Proportion action command (/P-CON)

Parameter	Signal	Type	Default	State	Meaning	Modify	Effective
P5-21	/P-CON	Input	n.0000	Effective	Run in P control mode	Any	Re-power on
				Ineffective	Run in PI control mode		
1. /P-CON is the speed control mode signal selected from PI (proportion integral) and P (proportion). 2. If set to P control mode, the motor rotate and micro-vibration caused by speed command input drift can be decreased. But the servo stiffness will decrease. 3. /P-CON signal can be distributed to input terminal via parameter P5-21. Refer to chapter 5-12-1.							

5-4-5. Zero clamp (/ZCLAMP)

(1) Function

This function is used when host controller uses speed command input and the servo system isn't configured the position loop. In other words, the function will be used when the motor must stop and enter lock state even the V-REF input voltage is not zero.

When set ON the zero clamp function, it will configure the position loop inside the servo, the motor will do zero clamp within ± 1 pulse at this position. The motor will return to zero clamp position even it is run by external force.

The present speed must be smaller than zero clamp speed when using zero clamp function, it can clamp the motor shaft from moving. The motor will switch from speed mode to position mode when starting the zero clamp function. At this time, rotate the motor shaft, it will return to the original position. It will not return to original position in speed mode, because it has no position feedback.

(2) Input signal setting

Parameter	Signal	Suitable mode	Default	Meaning	Modify	Effective
P5-31	/Z-CLAMP	3, 4, 7	n.0000	Zero clamp	Any	At once

Note: /Z-CLAMP signal is distributed to input terminal by parameter P5-31, refer to chapter 5-12-1.
Range: 0000-0014.

(3) Parameter setting

P3-13	Zero clamp speed					
	Unit	Default setting	Range	Suitable mode	Change	Effective
	rpm	10	0~10000	3, 4, 7	Any	At once

P3-12	Zero clamp mode					
	Default setting	Range	Suitable mode	Meaning	Change	Effective
	0	0~2	3, 4, 7	Set zero clamp mode	Servo OFF	At once

P3-12 setting	Contents
0	ZCLAMP input signal is ON, forced speed command is 0, when the speed below P3-13, switch to position mode and the servo lock in this position.
1	ZCLAMP input signal is ON, forced set the speed command to 0.
2	ZCLAMP input signal is ON, the speed below P3-13, switch to position mode and the servo lock in the position. Note: after entering zero clamp mode, present setting speed is higher than P3-13, motor doesn't run, the ZCLAMP signal must be OFF, then motor will run again.
3	ZCLAMP signal is ON, the setting speed is less than P3-13, switch to position control mode, and servo is locked at this position. At this time, if setting speed is over P3-13, the motor will run again.

5-4-6. Speed coincidence checking (/V-CMP)

When motor speed is equal to the command speed, servo outputs speed coincidence signal (V-CMP).

Parameter	Signal	Default	Meaning	Suitable mode	Modify	Effective
P5-39	/V-CMP	n.0000	Speed coincidence checking signal	3, 4, 7	Any	At once

Range: 0000-0013. Distribute to output terminal through P5-39. When it set to 0002, it means output from SO2.

P5-04	Speed coincidence signal width					
	Unit	Default	Range	Suitable mode	Modify	Effective
	rpm	50	0~10000	3, 4, 7	Servo OFF	Immediately

If the difference between motor speed and command speed is less than the value of P5-04, servo outputs /V-CMP signal.
There is default 10rpm hysteresis loop, please refer to chapter 5-11-4 for hysteresis loop.

5-4-7. Torque limit

1. Internal torque limit (output torque max value limit)

The function is to limit the max output torque by parameters.

P3-28	Internal Forward torque limit					
	Unit	Default	Range	Suitable mode	Modify	Effective
	1%	300	0~300	All modes	Servo OFF	Immediately
P3-29	Internal Reverse torque limit					
	Unit	Default	Range	Suitable mode	Modify	Effective
	1%	300	0~300	All modes	Servo OFF	Immediately

1. This parameter is always effective, if this parameter value is less than external torque limit value, the final limit value is this parameter.
2. The unit is percent of the motor rated torque; the default value is 300%. The real output torque is different for each type.

2. External torque limit (via input signal)

This function is used in machine motion or timing torque limit. For example: press stop action or robot workpiece protection.

The torque limit value will be effective when the input signal is ON.

P3-30	Forward external torque limit					
	Unit	Default	Range	Suitable mode	Modify	Effective
	1%	300	0~300	2, 3, 4, 5, 6, 7	Any	Immediately
P3-31	Reverse external limit					
	Unit	Default	Range	Suitable mode	Modify	Effective
	1%	300	0~300	2, 3, 4, 5, 6, 7	Any	Immediately

The unit is the percent of motor rated torque; the default value is 300%.

Parameter	Signal	Type	Default	Meaning	Modify
P5-25	/P-CL	Input	n.0000	The necessary condition to use forward external torque limit	Range: 0000-0015.
P5-26	/N-CL	Input	n.0000	The necessary condition to use reverse external torque limit	Range: 0000-0015.

Notes: these parameters are the necessary conditions for using forward or reverse external torque limit. /P-CL, /N-CL can be distributed to input terminal by parameter P5-25, P5-26. Refer to chapter 5-12-1.

3. External torque limit (via analog voltage command)

This function control the torque via analog voltage. T-REF terminal is used as analog voltage command terminal. Please note in external analog torque control mode, this function cannot be used.

Parameter	Function	Set value	Suitable mode	Meaning	Modify	Effective
P3-23	Distribute function to T-REF	0	1, 3, 4, 6, 7	Make T-REF as external torque limit input	Servo OFF	At once

1. For analog voltage command input of torque limit. Get the absolute value of the voltage, the torque limit value based on the absolute value is suitable for forward and reverse direction.
2. When it is used as torque limit, the value is related to voltage command and P3-24. For example, P3-24=1000, T-REF voltage command is 5.0V, the torque limit value is 50% of rated torque.

4. Relationship of the parameters

The following are the relationship of internal torque limit, external torque limit, P-CL, /N-CL and T-REF.

TREF distribution	P-CL/N-CL status	Final forward torque	Final reverse torque
0	0	P3-28 decide	P3-29 decide
	1	The smaller one of internal forward torque limit and external forward torque limit	The smaller one of internal reverse torque limit and external reverse torque limit
1	No effect	The smaller one of internal forward torque limit and external analog torque	The smaller one of internal reverse torque limit and external analog torque
3	0	P3-28 decide	P3-29 decide
	1	The smaller one of internal forward torque limit and external analog torque	The smaller one of internal reverse torque limit and external analog torque

5. Output torque up to limit value signal

The signal means the motor output torque reaches limit value.

Parameter	Signal	Type	Default	Meaning	Modify	Effective	Suitable mode
P5-42	/CLT	Output	n.0000	Output signal when motor output torque up to P5-28, P5-29.	Any	At once	3, 4, 6, 7

Note: Range: 0000-0013. /CLT signal can be distributed to output terminal by parameter P5-42. When it is set to 0001, the signal will output from SO1 terminal. Refer to chapter 5-12-3.

5-4-8. Soft start

P3-09	Soft start acceleration time					
	Unit	Default	Range	Suitable mode	Modify	Effective
	1ms	0	0~65535	3, 4, 7	Any	Servo OFF
P3-10	Soft start deceleration time					
	Unit	Default	Range	Suitable mode	Modify	Effective
	1ms	0	0~65535	3, 4, 7	Any	Servo OFF
1. Enable to do smooth speed control when input step speed command or choose internal speed. Other cases please set to 0. 2. acceleration/deceleration time is from stop state to rated speed but not from current speed to target speed. P3-09: the time from stop state to rated speed. P3-10: the time from rated speed to stop state.						

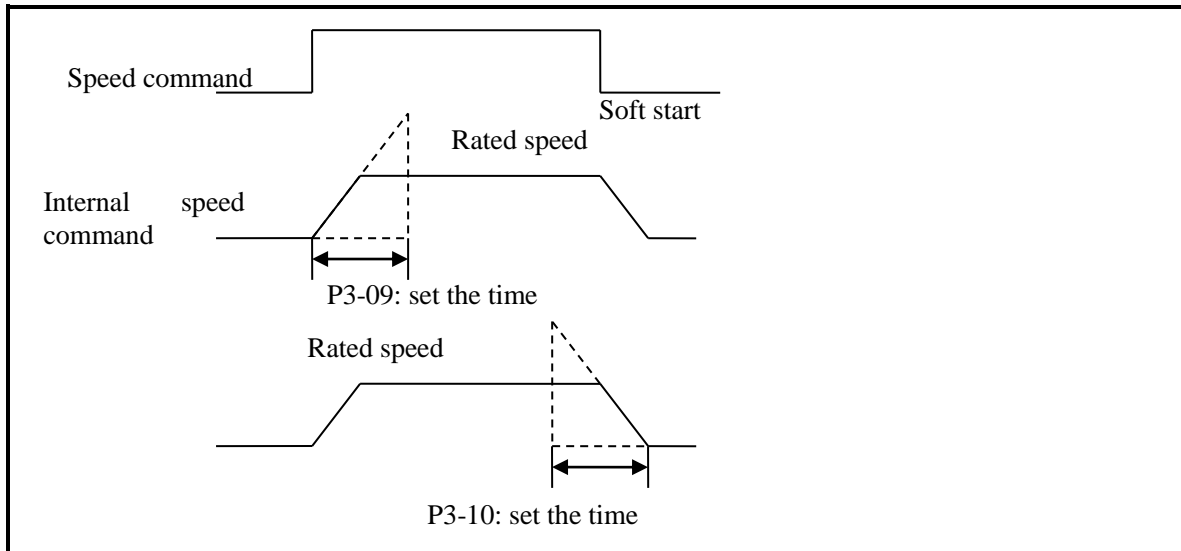

5-4-9. Filter

P1-22	Speed command filter mode					
	Default setting	Range	Suitable mode	Meaning	Change	Effective
	0	0, 1	3, 4, 7	Filter certain frequency command pulse	Any	At once

P1-22 setting	Contents
0	First order low pass filter
1	Smoothing filter

Filter time setting:

P1-23	Speed command filter time					
	Unit	Default setting	Range	Suitable mode	Change	Effective
	0.1ms	0	0~65535	3, 4, 7	Any	At once

5-4-10. Speed reach signal (/V-RDY)

Output speed reach signal V-RDY when the motor speed is equal to reach speed.

P5-51	Name	Default setting	Meaning	Suitable mode	Modify	Effective
	/V-RDY	n.0000	Speed reaching signal	3, 4, 7	Any	At once

Range: 0000-0013, distribute to the output terminal via P5-29. When P5-29=0002, it means output from SO2 terminal.



the output terminal only can have one function at the same time. Please refer to chapter 5-12-3.

P5-05	Reach detection speed					
	Unit	Default setting	Range	Suitable mode	Change	Effective
	rpm	1000	0~10000	3, 4, 7	Servo OFF	At once

If the motor speed absolute value is larger than P5-05, output the signal /V-RDY.



there is default hysteresis loop 10rpm, please refer to chapter 5-11-4.

5-4-11. Alarm speed

P3-21	Forward alarm speed					
	Unit	Default setting	Range	Suitable mode	Change	Effective
	1rpm	120% of rated speed	0~10000	All	Servo OFF	At once
P3-22	Reverse alarm speed					
	Unit	Default setting	Range	Suitable mode	Change	Effective
	1rpm	120% of rated speed	0~10000	All	Servo OFF	At once

Note: 1. the parameters P3-21 and P3-22 are effective in all the modes.
 2. the default value is 120% of rated speed. for example: rated speed is 1500, max speed is 1800; rated speed is 3000, max speed is 3600.
 3. these parameters are related to E-080. When the motor is out of control or the speed keeps rising caused by external force and over the alarm speed, servo will show E-080 alarm.

5-4-12. Speed command input dead area voltage

P3-03	Speed command input dead area voltage					
	Unit	Default setting	Range	Suitable mode	Modify	Effective
	0.001V	0	0~500	1, 2, 4	Any	At once

Note:

- (1) When the input speed command voltage is in the range of this parameter, the input command is seemed to be 0.
- (2) If there is fretting after calibrating the deviation, please increase the dead area voltage.

5-5. Speed control (internal speed)

Basic parameter		
Parameter	Name	Reference
P0-01	Control mode selection	5--1
P5-20	Servo ON signal /S-ON	5-2-1
P3-05	Internal speed 1	5-5-2
P3-06	Internal speed 2	
P3-07	Internal speed 3	
P5-27	/5SPD-D internal speed direction selection	5-5-3
P5-28	/SPD-A internal speed direction selection	
P5-29	/SPD-B internal speed direction selection	

Other parameters			
Key word	Parameter	Name	Reference
Proportion action	P5-21	Proportion action command /P-CON	5-4-4
Zero clamp	P5-31	Zero clamp /ZCLAMP	5-4-5
	P3-12	Zero clamp mode	

	P3-13	Zero clamp speed	
Speed coincidence checking	P5-39	/V-CMP speed coincidence checking	5-4-6
	P5-04	speed coincidence checking signal width /V-CMP	
Torque limit	P3-28	Internal forward torque limit	5-4-7
	P3-29	Internal reverse torque limit	
	P3-23	T-REF distribution	
	P3-30	Forward external torque limit	
	P3-31	Reverse external torque limit	
	P5-25	Forward external torque limit /P-CL	
	P5-26	Reverse external torque limit /N-CL	
	P5-42	Torque up to limit value output /CLT	
Soft start	P3-09	soft start acceleration time	5-4-8
	P3-10	soft start deceleration time	
Filter	P1-22	Position command filter mode	5-4-9
	P1-23	Speed command filter time	
Speed reach detection	P5-51	Speed reach output /V-RDY	5-4-11
	P5-05	Reach detection speed	

5-5-1. Control mode selection

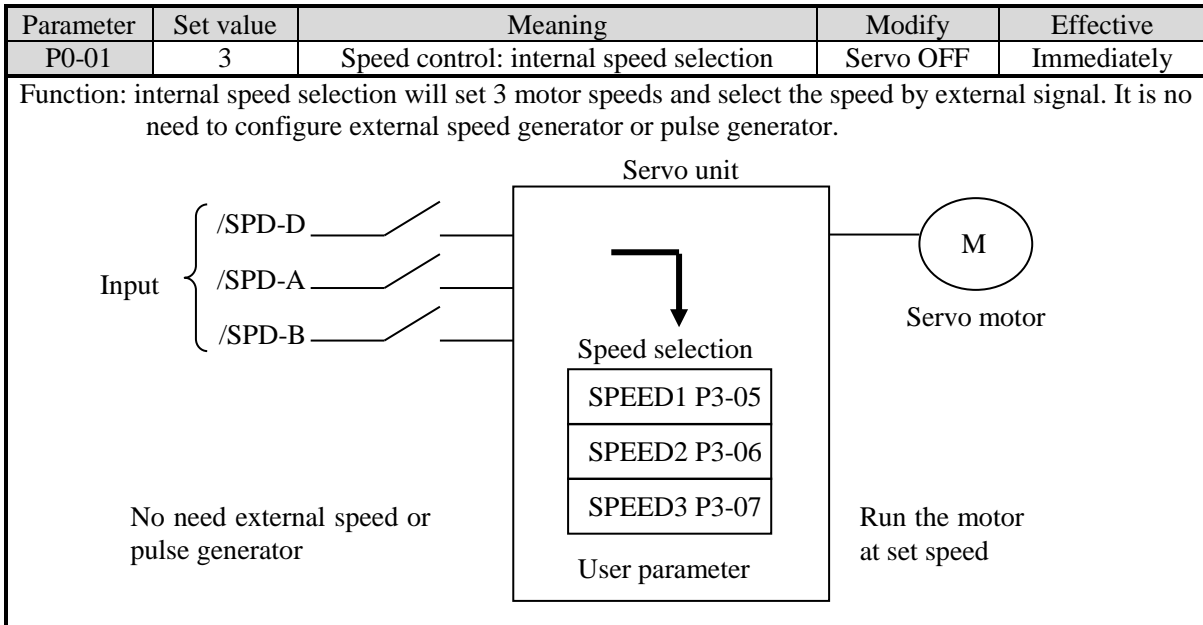

5-5-2. Internal speed setting

P3-05	Internal speed 1					
	Unit	Default	Range	Suitable mode	Modify	Effective
	1rpm	0	-9999~+9999	3	Any	Immediately
P3-06	Internal speed 2					
	Unit	Default	Range	Suitable mode	Modify	Effective
	1rpm	0	-9999~+9999	3	Any	Immediately
P3-07	Internal speed 3					
	Unit	Default	Range	Suitable mode	Modify	Effective
	1rpm	0	-9999~+9999	3	Any	Immediately

5-5-3. Input signal setting

Switch the running speed by below input signal:

Parameter	Signal	Default	Suitable mode	Modify	Modify	Effective
P5-27	/SPD-D	n.0000	1, 2, 3, 4	Range: 0000-0015. Distribute to input terminal through P5-27.	Any	At once
P5-28	/SPD-A	n.0000	3, 6	Range: 0000-0015. Distribute to input terminal through P5-28.		
P5-29	/SPD-B	n.0000	3, 6	Range: 0000-0015. Distribute to input terminal through P5-29.		

(1) Function realization

Input signal			Direction	Running speed
/SPD-D	SPD-A	SPD-B		
0	0	0	Forward	Internal speed is zero
	0	1		P3-05: SPEED1
	1	1		P3-06: SPEED2
	1	0		P3-07: SPEED3
1	0	0	Reverse	Internal speed is zero
	0	1		P3-05: SPEED1
	1	1		P3-06: SPEED2
	1	0		P3-07: SPEED3

(2) Running example

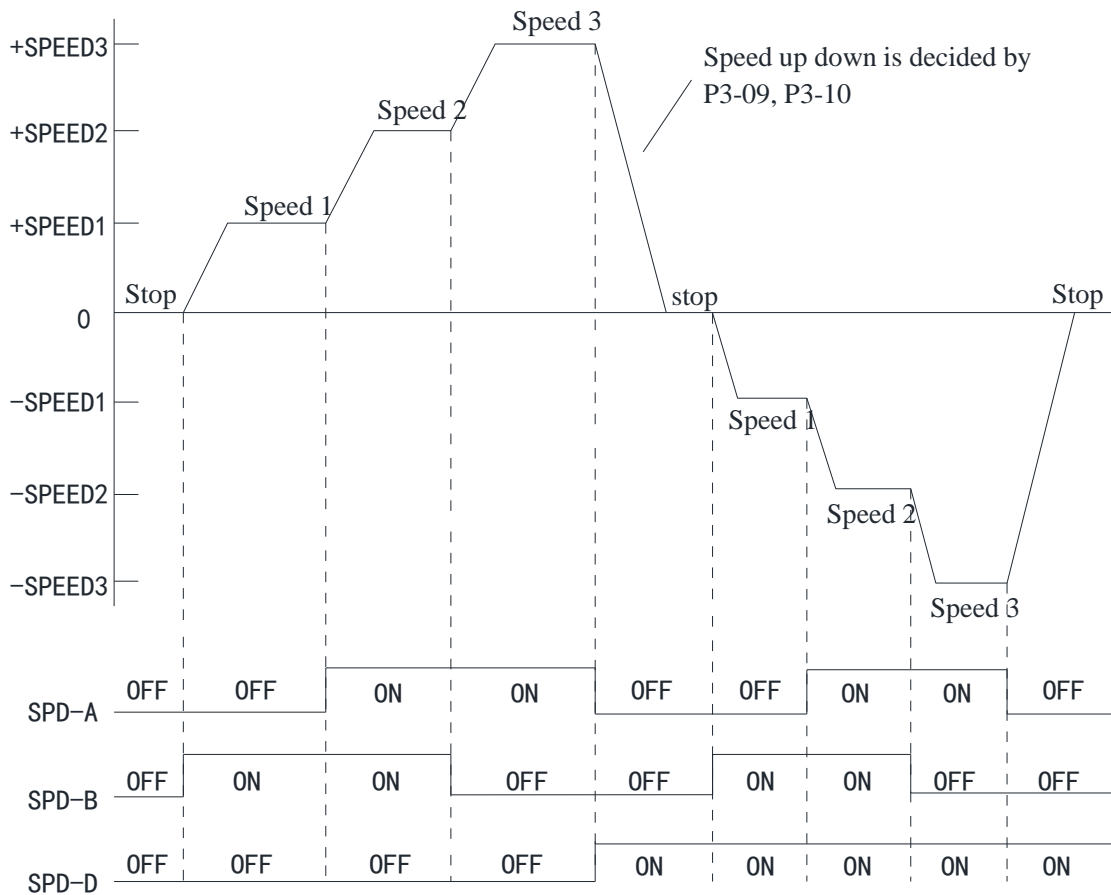

5-6. Speed control (pulse frequency command)

Basic parameter		
Parameter	Name	Reference
P0-01	Control mode selection	5-6-1
P5-20	Servo ON signal /S-ON	5-2-1
P0-10	Pulse command form	5-3-2
P0-15	Command pulse frequency at rated speed	5-6-3
P0-16	Speed command pulse filter time	5-6-4

Other parameters			
Key word	Parameter	Name	Reference
Proportion action	P5-21	Proportion action command /P-CON	5-4-4
Zero clamp	P5-31	Zero clamp /ZCLAMP	5-4-5
	P3-12	Zero clamp mode	
	P3-13	Zero clamp speed	
Speed coincidence checking	P5-39	/V-CMP speed coincidence checking	5-4-6
	P5-04	speed coincidence checking signal width /V-CMP	
Torque limit	P3-28	Internal forward torque limit	5-4-7
	P3-29	Internal reverse torque limit	
	P3-23	T-REF distribution	
	P3-30	Forward external torque limit	
	P3-31	Reverse external torque limit	
	P5-25	Forward external torque limit /P-CL	
	P5-26	Reverse external torque limit /N-CL	
	P5-42	Torque up to limit value output /CLT	
Speed reach detection	P5-51	Speed reach output /V-RDY	5-4-11
	P5-05	Reach detection speed	

5-6-1. Control mode selection

Parameter	Set value	Meaning	Modify	Effective
P0-01	7	Speed control: pulse frequency speed command	Servo OFF	Immediately
Function: speed command is decided by external pulse frequency, but not related to pulse quantity. The wiring is the same as position command. Select CW, CCW mode or direction + pulse mode, AB phase pulse mode.				

5-6-2. Pulse frequency command

Pulse frequency command is the same as external pulse command position control (mode 6), refer to chapter 5-3-2.

5-6-3. Command pulse frequency at rated speed

P0-15	command pulse frequency at rated speed					
	Unit	Default	Range	Suitable mode	Modify	Effective
	100Hz	1000	1~10000	7	Servo OFF	Immediately
Note: the unit is 100Hz. Example: P0-15=300, command pulse frequency at rated speed=30kHz; P0-15=1000, command pulse frequency at rated speed= 100kHz.						

5-6-4. Speed command pulse filter time

P0-16	speed command pulse filter time					
	Unit	Default	Range	Suitable mode	Modify	Effective
	0.01ms	100	0~10000	7	Any	Immediately

When the command pulse frequency is low, setting a suitable value for this parameter can decrease the speed fluctuation.

5-7. Torque control (analog voltage command) (only for DS3-PQA)

Parameter		
Parameter	Name	Reference
P0-01	Control mode selection	5-7-1
P3-23	T-REF distribution	
P3-24	The analog voltage of rated torque	5-7-2
P3-25	Analog voltage torque command filter	
P3-26	Torque command input dead zone voltage	
P5-20	Servo ON signal /S-ON	5-2-1

Other parameters			
Key words	Parameter	Name	Reference
Zero drift adjustment	F1-04	Torque command offset auto-adjustment	5-7-3
Filter	P3-25	Torque command filter time	5-7-4
Speed limit	P3-00	V-REF distribution	5-7-5
	P3-16	Internal forward speed limit for torque control	
	P3-17	Internal reverse speed limit for torque control	
	P5-43	Speed reach limit output /VLT	
/SPD-D direction selection	P5-27	Speed direction changing	5-5-3

5-7-1. Control mode selection

Parameter	Set	Function	Modify	Effective
P0-01	2	Torque control: analog voltage command	Servo OFF	Immediately

Function: Control the torque by the analog voltage signal input from T-REF terminal.
Direction switching: negative or positive voltage or SPD-D (P5-27).

5-7-2. The analog value of rated torque

parameter	Name	Default setting	Suitable mode	Meaning	Change	Effective
P3-23	T-REF distribution	0	All	T-REF input as speed command	Servo OFF	At once
P3-24	Analog value of rated torque					
	Unit	Default setting	Range	Suitable mode	Change	Effective

	0.001V	10000	1500~30000	All	Servo OFF	At once
Function: set the speed command voltage (T-REF) to run the servo motor at rated speed Example: P3-24=5000, motor run at rated torque when analog input voltage is 5.00V P3-24=8000, motor run at rated torque when analog input voltage is 8.00V Note: analog voltage command input for torque limit has no polarity. Get the absolute value whatever it is positive or negative voltage. The torque limit value based on this absolute value is fir for forward and reverse direction. Analog input signal max allowable voltage is ±10V, do not give the signal out of this range.						
P3-25	Analog voltage torque command filter					
	Unit	Default setting	Range	Suitable mode	Change	Effective
	0.01ms	0	0~10000	All	Servo OFF	At once
The analog torque command input please refer to chapter 3-2-4						
P3-26	Torque command input dead zone voltage					
	Unit	Default setting	Range	Suitable mode	Change	Effective
	0.001V	0	0~500	2	Any	At once
Note: when the input torque command voltage is smaller than this parameter, it considers the input torque command is 0. If there is fretting after calibrating the deviation, please increase the dead area voltage.						

5-7-3. Torque command offset autoadjustment (F1-04)

The motor will run at microspeed even the command voltage is 0V in analog voltage torque mode. This situation will happen when host controller or the command voltage of external circuit has micro-offset (mV). Use the operate panel to auto-adjust the offset.

Take away the analog signal from servo CN1 port in servo bb state (not enabled), do the following steps:

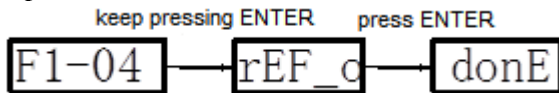

Press STATUS/ESC to exit this function.

Note:

- (1) Present analog voltage is 0V, follow the above steps to calibrate, 0V is 0% of output torque, the motor reverse output the torque below 0V, motor forward output the torque above 0V. if the present analog voltage is 5V, follow the above steps to calibrate, 5V is 0% of output torque, the motor reverse output the torque below 5V, motor forward output the torque above 5V.
- (2) If there is still fretting after calibrating, increase P3-26, if set to 5, the dead area voltage is 0.005V.

5-7-4. Torque command filter time

P3-25	torque command filter time					
	Unit	Default	Range	Suitable mode	Modify	Effective
	0.01ms	0	0~10000	All	Any	Immediately
1-time delay filter will smooth the torque command. If set the value too large, the reponse will be decreased.						

5-7-5. Torque limit

5-7-5-1. Internal speed limit

Limit the speed of torque control by setting below parameters:

P3-16	internal forward speed limit in torque control mode					
	Unit	Default	Range	Suitable mode	Modify	Effective
	1rpm	Motor rated	0~10000	1, 2	Any	Immediately
Note: the actual speed is max speed even this parameter speed is larger than the max speed.						

P3-17	internal reverse speed limit in torque control mode					
	Unit	Default	Range	Suitable mode	Modify	Effective
	1rpm	Motor rated	0~10000	1, 2	Any	Immediately
Note: the actual speed is max speed even this parameter speed is larger than the max speed.						

5-7-5-2. External speed limit

Limit the speed output of torque control mode by the analog voltage command input from V-REF terminal.

Parameter	Function	Set value	Meaning	Modify	Effective
P3-00	V-REF function distribution	1	Make V-REF as external speed limit input, actual speed limit depends on external analog speed limit	Servo OFF	Immediately
<p>1. The analog voltage has no polarity. The absolute value of the voltage is suitable for forward and reverse direction.</p> <p>2. The parameter value is related to voltage command and P3-01 when it is used as speed limit value. For example: P3-01=5000 (voltage of rated speed is 5.0V), V-REF voltage command is 1.0V, the speed limit is 20% of rated speed.</p>					

5-7-5-3. Speed up to limit value output

Parameter	Signal	Default	Meaning	Modify	Suitable mode	Effective
P5-43	/VLT	n.0000	Speed limit checking	Any	1, 2, 6	At once
Range: 0000-0013. Distribute to output terminal through P5-43. When it set to 0001, it means output from SO1.						

5-8. Torque control (internal setting)

Basic parameter		
Parameter	Name	Reference
P0-01	Control mode selection	5-8-1
P5-20	Servo ON signal /S-ON	5-2-1
P3-33	Internal torque command	5-8-2

Other parameters			
Key words	Parameter	Name	Reference
Filter	P3-25	Torque command filter time	5-7-4
Speed limit	P3-16	Internal forward speed limit of torque control	5-7-5
	P3-17	Internal reverse speed limit of torque control	
	P3-14	Forward max speed limit	
	P3-15	Reverse max speed limit	
	P3-00	V-REF function distribution	
	P5-43	Speed up to limit value output	
/SPD-D direction selection	P5-27	Speed direction change	5-5-3

5-8-1. Control mode selection

Parameter	Set value	Function	Modify	Effective
P0-01	1	Torque control: internal setting	Servo OFF	Immediately
Function: Control the torque by internal torque command.				

5-8-2. Internal torque command

P3-33	Internal torque command					
	Unit	Default	Range	Suitable mode	Modify	Effective
	1% rated torque	0	-300~+300	1	Any	Immediately
The unit of this parameter is 1% of the rated torque. For example: P3-33=50, motor forward run with 50% of the rated torque; P3-33= -20, motor reverse run with 20% of the rated torque.						

5-9. Motion fieldbus control (position mode) (only for DS3E)

Motion control is the real-time management for mechanical part position and speed, make the movement according to the expected motion track and parameters.

- XDC series PLC use fieldbus motion control mode to replace the pulse outputting mode. It is bus communication mode, baud rate is 3M, the system speed is faster, the wiring is simple and sharing.
- Use XINJE industry fieldbus communication protocol, support XINJE fieldbus products.

Fieldbus parameters							
parameter	Function	Range		Set value	Default value	Modify	Effective
P0-01	Control mode	1: torque (command) 2: torque (analog) 3: speed (terminal command) 4: speed (analog) 5: position (internal) - cannot support 6: position (pulse) 7: speed (pulse) 10: fieldbus position mode		10	6	Servo OFF	at once
P0-03	Enable mode	1: IO enable 2: software enable 3: fieldbus enable		3	1	Servo OFF	At once
P7-00	RS485 station no.	1~20			1	Servo OFF	At once
P7-01	RS485 serial port parameters	n.xx□□	Baud rate 06: 19200 07: 38400 08: 57600 09: 115200 0A: 192000 0B: 256000 0C: 288000 0D: 384000 0E: 512000 0F: 576000 10: 768000 11: 1M 12: 2M 13: 3M	2213	2206	Servo OFF	At once

			14: 4M 15: 5M 16: 6M				
		n.x□XX	Stop bit: 0: 2 bits 2: 1 bit				
		n.□XXX	Parity bit 0: no parity 1: odd parity 2: even parity				
P7-02	RS485 communication protocol	1: Modbus 2: XNet		2	2		
P7-05	Slave station quantity				10		
P7-06	Repeat times				3		

Monitoring parameters

parameter	Explanation	Mark
U0-61	Communication error times	
U0-62	Synchronization frame receive error times (overtime or data error)	
U0-64	Data frame receive error times (overtime or data error)	
U0-66	CRC error times	
U0-67	UART error times	UART module error reasons: 1. RS485 noise is too large 2. CPU hasn't read offset register data in time caused the data damaged.
U0-68	Communication overtime times	If the servo continuous communication error period \geq P7-06, U0-68 +1, servo XNet state switches to "initial state", the priority of UART decreases, wait the synchronization frame, servo will not alarm right now.

5-10. Absolute encoder servo drive

Basic parameters		
Parameter	Name	Use
U0-57	Absolute encoder present position feedback	Read double word address 0x1039(hex), it is present encoder position, with negative and positive pulses.
U0-58		
F1-06	Absolute encoder clear circles	Write 1 in address 0x2106(hex) can clear the circles(effective when servo is in bb state, write 0 in 0x2106 after clearing)

Absolute encoder servo no need origin reset after power on again.

Servo drive model: DS3-□□ P □-PTA/PNA

Servo motor model: MS-□□ ST-T □□□□□ B/BZ-□□ P □

Servo drive model	Servo motor model	Cable	Encoder
DS3-20P1-PNA	MS-40ST-T00330B-20P1	Encoder cable CP-DP-B-02 (02 is length) Power cable CM-P07-02	20-bit absolute encoder
DS3-20P2-PNA	MS-60ST-T00630B-20P2 MS-60ST-T00630BZ-20P2		
DS3-20P4-PNA	MS-60ST-T01330B-20P4 MS-60ST-T01330BZ-20P4		
DS3-20P7-PNA	MS-80ST-T02430B-20P7 MS-80ST-T02430BZ-20P7		
DS3-21P5-PTA	MS-130ST-T10015B-21P5	Encoder cable CP-DL-B-02	17-bit absolute

	MS-130ST-T10015BZ-21P5 MS-130ST-T06025B-21P5 MS-130ST-T06025BZ-21P5	Power cable CM-L15-02	encoder
--	---	-----------------------	---------

5-10-1. Absolute encoder servo encoder cable

15-core aviation plug—encoder cable

5	4 blue (SD+)	3 blue/black(SD-)	2	1 shield
10	9 green(battery+)	8 red(5V)	7 green/black(battery-)	6 black (0V)
15	14	13	12	11

DB9 female port related to the 15-core aviation plug

5 shield	4 blue (SD+)	3 blue/black(SD-)	2	1
10	9 green(battery+)	8 red(5V)	7 green/black(battery-)	6 black(0V)
15	14	13	12	11

15-core AMP plug –encoder cable

5 shield	4 blue(SD+)	3 blue/black(SD-)	2	1
10	9 green(battery+)	8 red(5V)	7 green/black(battery-)	6 black(0V)
15	14	13	12	11

DB9 female port related to 15-core AMP plug

5 shield	4 blue(SD+)	3 blue/black(SD-)	2	1
10	9 green(battery+)	8 red(5V)	7 green/black(battery-)	6 black(0V)
15	14	13	12	11

5-10-2. Read the absolute encoder servo position

The encoder position information is transferred through RS485 port according to Modbus-RTU protocol.

17-bit absolute encoder, the pulse per circle is 131072.

U0-57(Modbus address is H1039), double word, encoder present position.

■ RS-485 communication

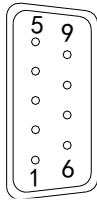

CN1 (DB9 male port): the pin definition at drive side

Pin	Name
CN1-2	A
CN1-3	B

Communication parameter explanation:

RS485 port default communication parameters: baud rate 19200bps, data bit 8, stop bit 1, even parity, modbus station no. 1.

Modbus station number can be set through P7-00:

Parameter	Function	Default setting	Setting range	Effective time
P7-00	Modbus station no.	1	0~255	Servo OFF



P7-00 is RS485 port modbus station no.

P7-01 communication parameter:

Parameter	Function	Default setting	Setting range	Effective time
n.xx□□	Baud rate	06	00~10 00: 300 01: 600 02: 1200 03: 2400 04: 4800 05: 9600 06: 19200 07: 38400 08: 57600 09: 115200 0A: 192000 0B: 256000 0C: 288000 0D: 384000 0E: 512000 0F: 576000 10: 768000 11: 1M 12: 2M 13: 3M 14: 4M 15: 5M 16: 6M	Servo OFF
n.x□□□	Stop bit	2	0: 2-bit, 2: 1-bit	Servo OFF
n.□□□□	Parity bit	2	0~2 0: no parity, 1: odd parity, 2: even parity	Servo OFF
Note: data bit cannot be set, it is 8-bit.				

P7-02 is RS485 communication protocol:

Parameter	Function	Default setting	Setting range	Effective time
P7-02	RS485 communication protocol	1	1: Modbus Rtu protocol 2: Xnet fieldbus protocol	Servo OFF



- (1) support standard Modbus-RTU protocol, used as Modbus slave device.
- (2) RS232 and RS485 port can be used at the same time.

5-10-3. The use and replacement of battery

When the servo power supply is OFF, the battery can keep the absolute encoder position information. When the servo power is on again, the upper device can read the motor encoder present position through Modbus communication.

Battery specification: No.5 battery, 3.6V (ER14505 AA 3.6V).

When the battery voltage is below 2.75V, servo drive will show E-222 alarm (absolute encoder battery under voltage). The alarm only outputs when the servo is ON.

Note:

- (1) Please change the battery every two years.
- (2) If the battery is under voltage, when the servo power supply is OFF and ON again, the data in the absolute encoder will miss. Please protect the program and avoid equipment error action.
- (3) Please check the firmware version U2-22/U2-23, for the version after 20160304, P0-79=1 means battery under voltage alarm is invalid, P0-79=0 means battery under voltage alarm is valid.

The steps to replace the battery:

Please replace the battery when the servo power supply is ON, otherwise the encoder data will be error. After replacement, please re-power on the servo drive to clear the E-222 alarm.

5-11. Other output signals

5-11-1. /ALM and /ALM-RST

- Servo alarm output /ALM

Parameter	Signal	Type	Default	Suitable mode	Modify	Effective
P5-47	/ALM	Output	n.0002	All	Any	At once
Output always open signal from SO2						

■ Alarm reset /ALM-RST

Parameter	Signal	Type	Default	Meaning	Modify	Effective
P5-24	/ALM-RST	Input	n.0002	Input always open signal from SI2	Any	At once
<ol style="list-style-type: none"> Find the alarm reason and fix it, then clear the alarm via this signal. /ALM-RST can be distributed to input terminal via this parameter. As the alarm signal is related to the safe running of servo, /ALM-RST signal cannot be set to always effective. (n.0010); The alarm related to encoder such as E-013□ (0, 1, 2), E-014□ (0, 1, 2) cannot be reset via /ALM-RST. The range is 0000-0015. /ALM-RST can be distributed to input terminal via parameter P5-24. 						

5-11-2. /WARN

Set the warn output threshold. When the motor speed is larger than the threshold, output /WARN.

P3-19	Forward warn speed					
	Unit	Default setting	Range	Suitable mode	Change	Effective
	1rpm	Related to the motor	0~10000	All	Servo OFF	At once
P3-20	Reverse warn speed					
	Unit	Default setting	Range	Suitable mode	Change	Effective
	1rpm	Related to the motor	0~10000	All	Servo OFF	At once

Parameter	Signal	Type	Default	Meaning	Range
P5-45	/WARN	Output	n.0000	Warning output	0000-0013
When the warning happens, servo will not be forced OFF but output the warning. /WARN can be distributed to input terminal via parameter P5-45.					

5-11-3. Rotation checking (/TGON)

(1) Signal setting

Parameter	Signal	Type	Default	Suitable mode	Modify	Effective
P5-40	/TGON	Output	n.0000	All	Any	At once
<ol style="list-style-type: none"> The servo will be considered in the rotation when the servo motor speed is higher than P5-03. The range is 0000-0013. /TGON can be distributed to output terminal via parameter P5-40, refer to chapter 5-12-3. 						

(2) Parameter setting

P5-03	Internal torque command setting					
	Unit	Default	Range	Suitable mode	Modify	Effective
	1rpm	50	1~10000	All the modes	Servo OFF	Immediately
Set the range of rotation checking output. If servo motor speed is up to P5-03, the servo motor is considered to be running and output rotation checking signal (/TGON). There is default 10rpm hysteresis loop, please refer to chapter 5-11-4.						

5-11-4. Hysteresis loop

The hysteresis loop can prevent the system oscillation caused by parameter fluctuating around certain value. There is hysteresis loop width after setting the hysteresis loop value. It will act when the parameter is larger than certain value. It will release the action when the parameter is smaller than another value. The loop width decides the interval time of action. The action is sensitive and frequent for small loop width. The action is slow for large loop width. Please note that rotation detection speed (P5-03), same speed detection speed (P5-04), reach detection speed (P5-05) all have 10rpm hysteresis loop. For example, P5-03 set to 50, rotation detection/TGON output terminal is SO3.

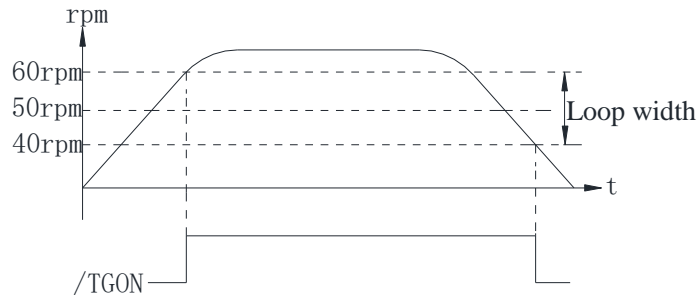

5-11-5. Servo ready (/S-RDY)

It will output /S-RDY signal when servo power on and no alarm.

Parameter	Signal	Default	Meaning	Modify	Effective
P5-41	/S-RDY	n.0003	SO3 and COM pass through when servo is ready	Any	At once
		n.0013	SO3 and COM cut off when servo is ready		
The range is 0000-0013. It can distribute to other output terminal through P5-41. Refer to chapter 5-12-3.					

5-11-6. Encoder Z phase output (/Z) (only for DS3-PQA/DS3-PTA)

Parameter	Signal	Default setting	Meaning	Range	Modify	Effective
P5-48	/Z	n.0000	Default not distribute to terminal	0000~0013	Any	At once
P5-19	Z phase pulse width	2ms	Z phase pulse width	2~20	Any	At once

1. /Z signal can be distributed to the output terminal through P5-48, refer to chapter 5-12-3.
2. Z phase signal is single pulse output mode, the default pulse width is 2ms, it can set through P5-19, it is not related to the motor speed.

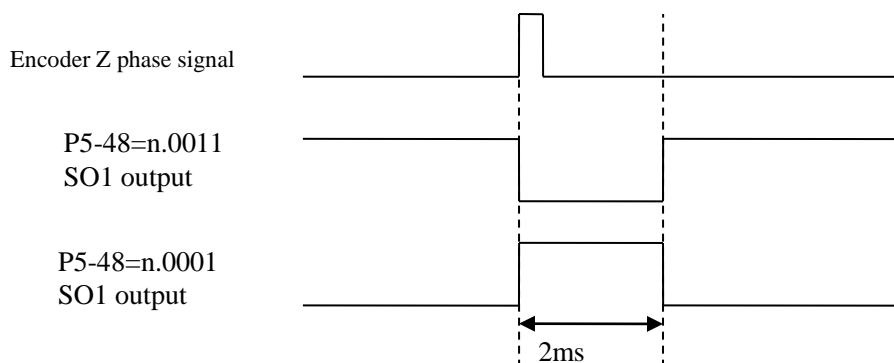

5-11-7. ABZ phase feedback signal of encoder (CN1 15-pin support)

1. Wiring diagram

DS3-2□P□-PQA/ DS3-4□P□-PQA 和 DS3L-2□P□-PQA/ DS3L-4□P□-PQA support differential output AB phase feedback signal.

Please see the following wiring diagram of DS3-21P5-PQA and Xinje PLC XC3-32RT-E.

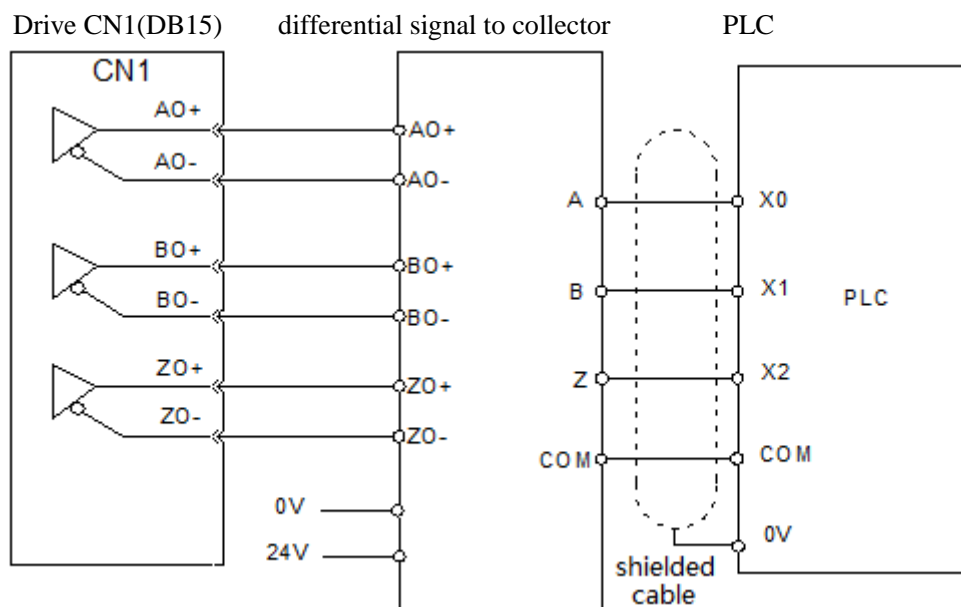

2. Encoder feedback pulses per circle (DS3L cannot support)

P0-18	Encoder feedback pulse per circle (low bit)					
	Unit	Default setting	Range	Suitable mode	Change	Effective
	1	2500	0~9999	All	Servo OFF	At once
P0-19	Encoder feedback pulse per circle (high bit)					
	Unit	Default setting	Range	Suitable mode	Change	Effective
	10000	0	0~65535	All	Servo OFF	At once
P0-20	Encoder pulse frequency division (numerator)					
	Unit	Default setting	Range	Suitable mode	Change	Effective
	—	1	1~65535	All	Servo OFF	At once
P0-21	Encoder pulse frequency division (denominator)					
	Unit	Default setting	Range	Suitable mode	Change	Effective
	—	1	1~65535	All	Servo OFF	At once

Explanation:

1. encoder feedback pulse is decided by P0-18, P0-19. When P0-18=P0-19=0, encoder pulse frequency division will work. For example, the motor feedback 2500 pulses per circle, P0-18=P0-19=0 P0-20=1, P0-21=4, the calculation method is $(U2-21/22)*P0-20/P0-21$.

2. If it is single phase count, the count value is equal to setting value for motor rotating one circle. If it is AB phase count, the count value is 4 times of setting value for motor rotating one circle.

3. the feedback value should under 10000. If it is larger than 10000, the system will operate as 10000.

P0-17	Pulse frequency division output direction (DS3E/L cannot support)					
	Unit	Default setting	Setting range	Suitable mode	Modification	Effective
	—	0	0~1	All	Servo OFF	At once
0: same to count direction			1: reverse to count direction			

5-11-8. User-defined output signal

User can define 2 outputs. The defined method is SOx output when $A > B$ or $A < B$. A is 9 activating conditions, B is user-defined comparison value.

User-defined output 1:

P5-10	The trigger condition of user-defined output 1					
	Default trigger condition	Trigger condition setting	Unit	Suitable mode	Change	effective
	0	See below table	Related to trigger condition	All the modes	servo OFF	At once
P5-11	The comparison value for the trigger condition of user-defined output 1					
	Unit	Default setting	Range	Suitable mode	Change	Effective
	Related to trigger condition	0	-9999~9999	All the modes	Servo OFF	At once
P5-12	When $P5-10 \geq P5-11$ or $P5-10 < P5-11$, SOx output					
	Setting value	Function	Default value	Suitable mode	Change	Effective
	0	$P5-10 \geq P5-11$, SOx output	0	All the modes	Servo OFF	At once
	1	$P5-10 < P5-11$, SOx output				
	2	$P5-10$ absolute value $\geq P5-11$, SOx output				
3	$P5-10$ absolute value $\leq P5-11$, SOx output					
P5-13	User-defined output 1 hysteresis loop					
	Unit	Default setting	Range	Suitable mode	Change	Effective
	Related to trigger condition	0	-9999~9999	All the modes	Servo OFF	At once
P5-52	Output terminal setting of user-defined output 1					
	Signal name	Default setting	Meaning	Change		
	User-defined output 1	n.0000	Default setting is not distribute to the output terminal	Range 0000-0013, distribute to the output terminal through P5-52.		

User-defined output 2:

P5-14	The trigger condition of user-defined output 2					
	Default trigger condition	Trigger condition setting	Unit	Suitable mode	Change	Effective
	0	See below table	Related to trigger condition	All the modes	Servo OFF	At once
P5-15	The comparison value for the trigger condition of user-defined output 2					
	Unit	Default setting	Range	Suitable mode	Change	Effective
	Related to trigger condition	0	-9999~9999	All the modes	Servo OFF	At once
P5-16	When $P5-14 \geq P5-15$ or $P5-14 < P5-15$, SOx output					
	Setting value	Function	Default setting	Suitable mode	Change	Effective

	0	P5-14 \geq P5-15, SOx output		0	All the modes	Servo OFF	At once
	1	P5-14<P5-15, SOx output					
	2	P5-14 absolute value \geq P5-15, SOx output					
	3	P5-14 absolute value < P5-15, SOx output					
P5-17	User-defined output 2 hysteresis loop						
	Unit	Default setting	Range	Suitable mode	Change	Effective	
	Related to trigger condition	0	0~65535	All the modes	Servo OFF	At once	
P5-53	Output terminal setting of user-defined output 2						
	Signal name	Default setting	Meaning	Change			
	User-defined output 2	n.0000	Default setting is not distribute to the output terminal	Range 0000-0013, distribute to the output terminal through P5-53			



please refer to chapter 5-11-4 for hysteresis loop.

- Trigger conditions for choice

Trigger condition (P5-10/P5-14)		Meaning	Unit
DS3 series	DS3E/DS3L series		
0	0	-	—
7203	0203	Current command (torque command)	Rated current %
7205	0205	Current feedback (torque feedback)	Rated current %
7238	0238	Torque feedforward	
7301	0301	Speed command	rpm
7302	0302	Speed feedback	rpm
7307	0307	Speed deviation initial value	
7308	0308	Speed deviation filter value	rpm
7319	0319	Speed feedforward initial value	
7320	0320	Speed feedforward filter value	
4402	4402	Position command	1 command
4404	4404	Position feedback	1 command
1406	1406	Position deviation filter value	1 command
7501	0501	Bus voltage initial value	V
7502	0502	Bus voltage filter value	V
7503	0503	Drive internal temperature	°C

5-11-9. IO filter time

P5-18	I/O filter time					
	Unit	Default setting	Range	Suitable mode	Change	Effective
	ms	0	0~10000	All the modes	Servo OFF	At once

5-11-10. Switch the control mode

Servo can switch between submode 1 and 2 by external input signal.

(1) Switch signal

Parameter	Signal	Type	Default	Suitable mode	Modify	Meaning	Effective
P5-30	/C-SEL	Input	n.0000	All	Any	Switch the mode	At once

Note: Range: 0000-0015. /C-SEL can be distributed to input terminal via parameter P5-14, refer to chapter 5-12-1.

(2) Function realization

Signal	State	Control mode
/C-SEL	0	P0-01: submode 1
	1	P0-02: submode 2

5-12. I/O signal distribution

5-12-1. Input signal distribution

DS3-2□P□-PQA, DS3-4□P□-PQA

Parameter range: P5-20~P5-36

Parameter meaning	Set value	Meaning	Terminal voltage	Terminal state	Signal state
n.00 y x 00: no meaning y: 0 always open 1 always close x: input terminal no.	n.0000	Not distribute to terminal input	-	-	0
	n.000x	Input always open signal from SIx	H	Disconnect to 0V	0
			L	Connect to 0V	1
	n.0010	Set the signal to be always valid	-	-	1
	n.001x	Input always close signal from SIx	H	Disconnect to 0V	1
			L	Connect to 0V	0

Note: if the distributed terminal has other signal, set the signal to other terminal or set to unused.

Example: take the input signal /CLR (P5-24) of DS3-21P5-PQA as an example to explain the terminal distribution.

Wiring example of input signal

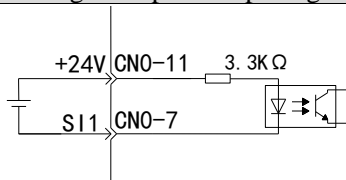

DS3-21P5-PQA: CN0-11 is +24V terminal, CN0-7 is S11 terminal. For the example, distribute /CLR signal to S11.

Parameter	Set value	Terminal state	Signal state	Meaning
P5-34	n.0001	Disconnect to 0V	0	Clear the pulse offset at the moment of S11 and 0V pass through
		Connect to 0V	1	
	n.0011	Disconnect to 0V	1	Clear the pulse offset at the moment of S11 and 0V cut off
		Connect to 0V	0	

Note: the default input of S11 is /SON, make sure to distribute P5-20(/SON) to other terminal or set to unused.

5-12-2. Default setting of input terminal

Input Type	SI1	SI2	SI3	SI4	SI5
DS3-2□P□-PQA DS3-4□P□-PQA	/S-ON	/ALM-RST	/P-OT	/N-OT	Not distribute

Note: the same input terminal can distribute one function parameter. If more function parameters distribute to the same terminal, the system will delete the former setting and keep the present setting.

5-12-3. Output terminal distribution

DS3-2□P□-PQA, DS3-4□P□-PQA

Parameter range: P5-37~P5-47, P5-51

Parameter meaning	Set value	Meaning	Signal state	Terminal state
n.00 y x 00: pointless y: 0 always open 1 always close x: output terminal no.	n.0000	Not distribute to terminal input	-	-
	n.000x	Output always open signal from SOx	0	Cut off with COM
			1	Pass through with COM
	n.0010	Set the signal to be always valid	-	-
	n.001x	output always close signal from SOx	0	Pass through with COM
1			Cut off with COM	

Note: If the distributed terminal has other signal, please set the signal to other terminal or set to unused.

Example: take /CLT signal of DS3-21P5-PQA as an example to explain output terminal distribution.

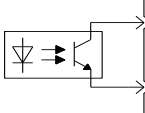
Output terminal wiring example				
		DS3-21P5-PQA: SO1 is CN0-12, COM is CN0-14.		
Parameter	Set value	/CLT	Terminal state	Meaning
P5-42	n.0001	0	SO1 and COM pass through	Output limit signal when motor torque reaches the set value
		1	SO1 and COM cut off	Output limit signal when motor torque reaches the set value

Note: the default output of SO1 is /COIN. Set the P5-38 (/COIN) to other terminal or unused in order to avoid terminal signal conflict.

5-12-4. Default setting of output terminal

Output terminal	SO1	SO2	SO3
Function	/COIN	/ALM	/S-RDY

Note: the same output terminal can distribute one function parameter. If more function parameters distribute to the same terminal, the system will delete the former setting and keep the present setting.

5-13. DS3-PTA series absolute encoder servo drive

Basic parameter		
parameter	Name	Reference
U0-57	Absolute encoder present position feedback	(0000~9999)*1
U0-58		(0000~65535)*10000
		Encoder pulse

Absolute encoder servo no need to reset origin after power on again and run directly.

Servo drive model: DS3-□□ P □-PTA

Servo motor model: MS-□□ ST-T □□□□□ B/BZ-□□ P □

Drive model	Motor model	Cable	Absolute encoder
DS3-20P4-PTA	MS-60ST-T01330B-20P4 MS-60ST-T01330BZ-20P4	Encoder cable CP-DP-B-02 (02 is 2meter) Power supply cable CM-P07-02	17-bit absolute encoder
DS3-20P7-PTA	MS-80ST-T02430B-20P7 MS-80ST-T02430BZ-20P7		
DS3-21P5-PTA	MS-130ST-T10015B-21P5 MS-130ST-T10015BZ-21P5 MS-130ST-T06025B-21P5 MS-130ST-T06025BZ-21P5	Encoder cable CP-DL-B-02 Power supply CM-L15-02	

5-13-1. Read the absolute encoder position

Servo drive transfers the encoder data through RS485 port and Modbus-RTU protocol.

The pulse numbers per circle is 131072 for 17-bit absolute encoder.

U0-57 (Modbus address is H1039): double words, encoder present position.

■ RS-485 port

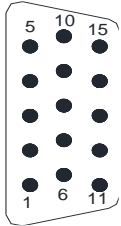
 <p>CN1 port: at drive side</p>	<table border="1"> <thead> <tr> <th>Pin no.</th> <th>Name</th> </tr> </thead> <tbody> <tr> <td>CN1-14</td> <td>A</td> </tr> <tr> <td>CN1-15</td> <td>B</td> </tr> </tbody> </table>	Pin no.	Name	CN1-14	A	CN1-15	B
Pin no.	Name						
CN1-14	A						
CN1-15	B						

Communication parameters:

RS485 port default parameters: baud rate 19200bps, data bit 8, stop bit 1, even parity, modbus station no. 1.

Modbus station no. setting:

Parameter	Function	Default setting	Range	Effective
P7-00	Modbus station no.	1	0~255	Servo OFF



P7-00 can set the RS485 port Modbus station no.

P7-01 communication parameter setting:

parameter	Function	Default setting	Range		Effective
n.xx□□	Baud rate	06	00~10 00: 300 01: 600 02: 1200 03: 2400 04: 4800 05: 9600 06: 19200 07: 38400 08: 57600 09: 115200	0A: 192000 0B: 256000 0C: 288000 0D: 384000 0E: 512000 0F: 576000 10: 768000 11: 1M 12: 2M 13: 3M 14: 4M	Servo OFF

				15: 5M 16: 6M	
n.X□XX	Stop bit	2	0: 2 bits, 2: 1 bit		Servo OFF
n.□XXX	Parity bit	2	0~2 0: no parity, 1: odd parity, 2: even parity		Servo OFF
Note: data bit cannot change, it is 8 bits					

P7-02 RS485 communication protocol setting:

Parameter	Function	Default setting	Range	Effective
P7-02	RS485 communication protocol	1	1: Modbus Rtu protocol 2: Xnet protocol	Servo OFF



(1) support standard Modbus RTU protocol, used as Modbus RTU slave device.

(2) RS232 and RS485 port can be used at the same time.

5-13-2. Battery using and changing

The battery can keep the absolute encoder position information when servo power is off. When the servo drive power on again, the upper controller can read the motor encoder present position through Modbus communication.

Battery specification: 3.6V No.5 type battery

The servo drive will show E- absolute encoder low battery alarm when the battery voltage is under 2.7V.

Note: if the battery voltage is low, the absolute encoder data will lose when the servo power on again.

The steps to change the battery:

- (1) Please change the battery when the servo is power on, otherwise the absolute encoder information will lose.
- (2) After changing the battery, please restart the servo drive to delete the low battery alarm.

5-14. Internal position mode (only for DS3E/DS3L)

Parameter		
Parameter	Name	Reference
P0-01	Control mode selection	5-4-1
P4-03	Internal position given mode	5-4-2
P4-10~P4-254	Internal 1~35 segment position parameters	5-4-3
P5-35	Change the step signal /CHGSTP	5-4-4
P5-32	Pause current signal /INHIBIT	5-4-5
P5-31	Skip current signal /Z-CLAMP	5-4-6
P5-20	Servo ON signal /S-ON	5-2-1
P4-04	Effective segment no.	5-4-3

Other parameters			
Key words	Parameter	Name	Reference
Find the origin	P4-00	The quantity pass through the Z phase signal after	5-4-7

		leaving the limit switch	
	P4-01	The speed near the limit switch	
	P4-02	The speed leave the limit switch	
	P5-27	/SPD-D: define the origin in position mode	
	P5-28	/SPD-A: find the reference origin at forward side in position mode	
	P5-29	/SPD-B: find the reference origin at reverse side in position mode	
Pulse error clear	P5-34	Pulse error clear	5-12-1
Positioning complete	P5-38	Positioning complete signal output /COIN	5-3-6
	P5-00	Positioning complete width	
Positioning near	P5-46	Positioning near signal output /NEAR	5-3-7
	P5-06	Positioning near signal width	
Set segment no. through communication	F2-09	Any setting of 35 segments position	5-4-8

5-14-1. Control mode selection

Parameter	Default	Meaning	Modify	Effective
P0-01	5	Control the position through servo internal register value	Servo OFF	Immediately

5-14-2. Internal position mode

Parameter	Content	Unit	Default	Suitable mode	Modify	Effective
P4-03	Internal position mode setting	—	n.0000	5	Servo OFF	Re-power on
	Parameter setting	Function	Default	Range		
	n.□XXX	No meaning				
	n.X□XX	Wait mode	0	0~1		
	n.XX□X	Change step mode	0	0~4		
	n.XXX□	Positioning mode	0	0~1		

Mode explanation:

(1) Wait mode

n.X□XX	Meaning
0	Wait for the completion of positioning
1	Not wait for the completion of positioning

Notes: the wait mode means whether the drive waiting for the completion of positioning in internal position setting mode. This is effective in any change step mode.

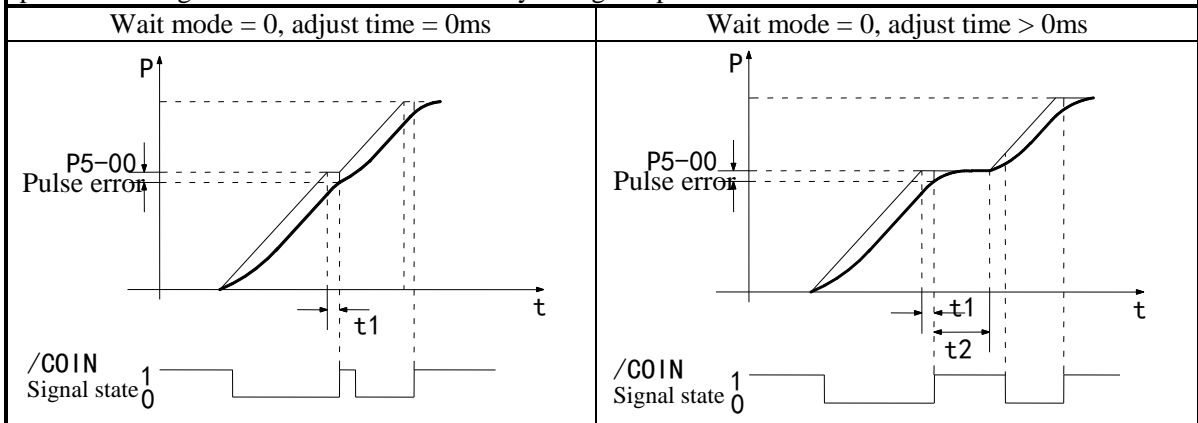

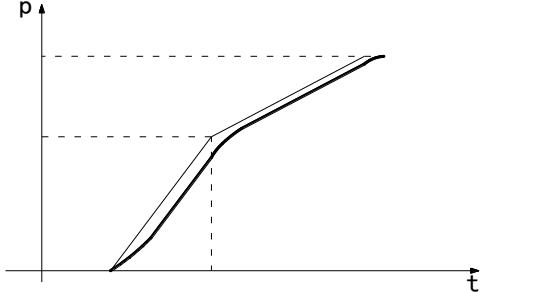
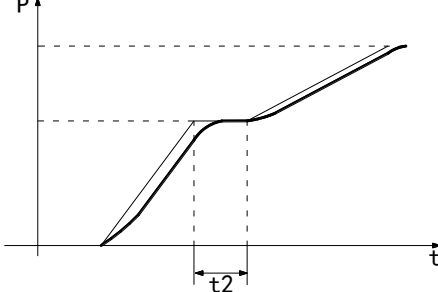
<p>After the drive output 1-segment position command, it will wait for the completion of motor positioning, and then start the next position command at once. T1 is positioning time, which means the time from pulse output complete to the output of positioning completion signal.</p>	<p>After the drive output 1-segment position command, it will wait for the completion of motor positioning, and pass the adjust time, then start the next position command. T1 is positioning time, t2 is adjust time. Refer to parameter P4-11.</p>
<p>Wait mode = 1, adjust time = 0ms</p>	<p>Wait mode = 1, adjust time > 0ms</p>
 <p>After the drive output 1-segment position command, it will not wait for the completion of motor positioning, and start the next position command at once.</p>	 <p>After the drive output 1-segment position command, it will not wait for the completion of motor positioning, but pass the adjust time, and then start the next position command. T2 is adjust time. Refer to parameter P4-11.</p>

(2) Change step mode

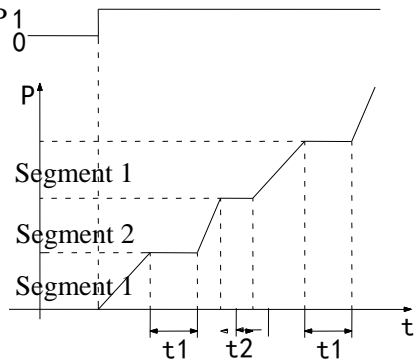
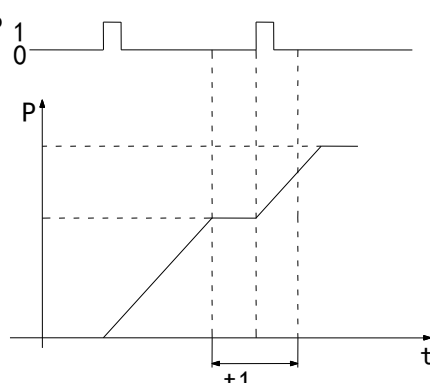
n.XX□X	Explanation
<p>0: Change the step when signal is ON, recycling</p>	 <p>t1=P4-11, t2=P4-21</p> <ol style="list-style-type: none"> If /CHGSTP is ON, servo will run segment 1 and 2. If /CHGSTP is OFF in one segment, servo will finish this segment and stop running the next segment.
<p>1: Change the step at the rising edge of the signal, single-step run</p>	 <p>Suppose there are 2 segments. t1=P4-11</p> <p>In this mode, the adjust time is ineffective. The servo will run the next command once the current pulse is finished.</p>

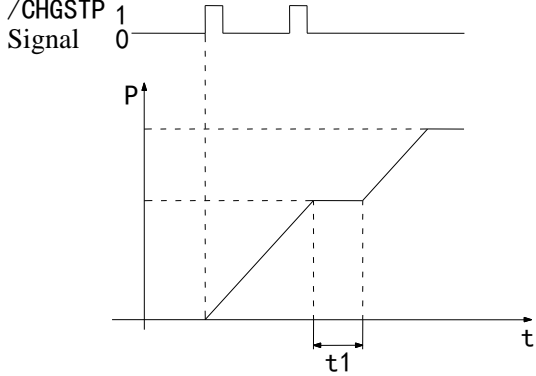
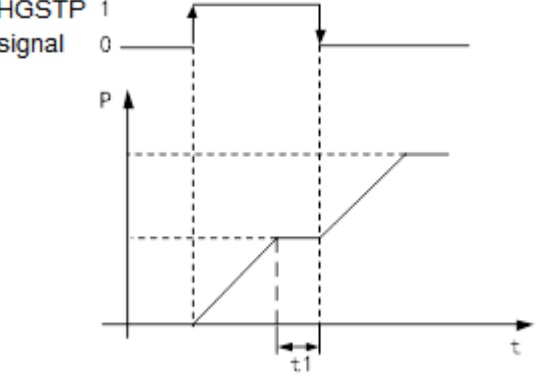
<p>2: Start at the rising edge of the signal, sequential run all, not recycling</p>	 <p>Suppose there are 2 segments. $t1=P4-11$ /CHGSTP signal is ineffective when one cycle has not been finished, such as the second /CHNGSTP signal in the diagram.</p>																				
<p>3: set segment no. through communication</p>	<p>Servo is ON, set parameter P2-09=0, then set the running segment.</p>																				
<p>4: /CHSTP double edge triggering</p>	 <p>/CHSTP rising edge triggers the first segment, the falling edge triggers the second segment.</p>																				
<p>5: /PREFA(P5-57) /PREFB(P5-58) /PREFC(P5-59) Choose the segment, the range is segment 1~3</p>	<table border="1" data-bbox="512 1370 1283 1541"> <thead> <tr> <th>/PREFC</th> <th>/PREFB</th> <th>/PREFA</th> <th>Segment</th> </tr> </thead> <tbody> <tr> <td>0</td> <td>0</td> <td>0</td> <td>-</td> </tr> <tr> <td>0</td> <td>0</td> <td>1</td> <td>1 (segment 1 position)</td> </tr> <tr> <td>0</td> <td>1</td> <td>0</td> <td>2 (segment 2 position)</td> </tr> <tr> <td>0</td> <td>1</td> <td>1</td> <td>3 (segment 3 position)</td> </tr> </tbody> </table>	/PREFC	/PREFB	/PREFA	Segment	0	0	0	-	0	0	1	1 (segment 1 position)	0	1	0	2 (segment 2 position)	0	1	1	3 (segment 3 position)
/PREFC	/PREFB	/PREFA	Segment																		
0	0	0	-																		
0	0	1	1 (segment 1 position)																		
0	1	0	2 (segment 2 position)																		
0	1	1	3 (segment 3 position)																		

The following input signal can switch the segment 1 to 3:

Parameter	Signal name	Default setting	Suitable mode	Setting range	Modify	effective
P5-57	/PREFA internal position segment 1	n.0000	5	Range 0000-0014, distribute to input terminal through P5-57	Any	At once
P5-58	/PREFB internal position segment 2	n.0000	5	Range 0000-0014, distribute to input terminal through P5-58		
P5-59	/PREFC internal position segment 3	n.0000	5	Range 0000-0014, distribute to input terminal through P5-59		

(3) Positioning mode

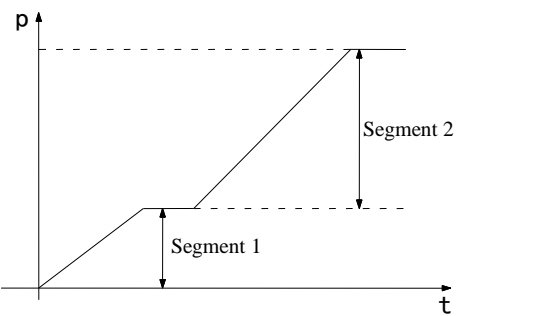
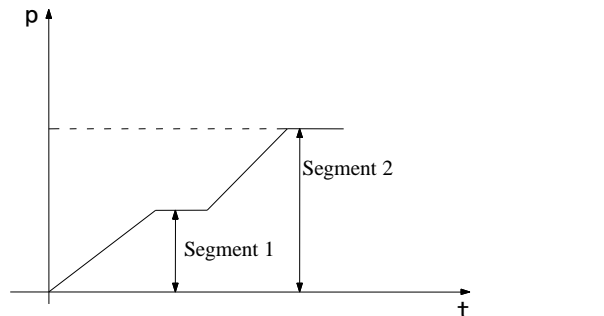
n.xxx□	Meaning
0	Relative positioning
1	Absolute positioning
0: relative positioning	1: absolute positioning (take the reference origin as the absolute positioning origin)
	

5-14-3. Position parameters from segment 1 to 35

P4-10+ (n-1) *7	Pulse number (low bit)					
	Unit	Default setting	Range	Suitable mode	Modify	Effective
	1 pulse	0	-9999~9999	5	Servo OFF	Immediately
P4-11+ (n-1) *7	Pulse number (high bit)					
	Unit	Default setting	Range	Suitable mode	Modify	Effective
	10000 pulses	0	-32767~32767	5	Servo OFF	Immediately
P4-12+ (n-1) *7	Speed					
	Unit	Default setting	Range	Suitable mode	Modify	Effective
	0.1rpm	0	0~10000	5	Servo OFF	Immediately
P4-13+ (n-1) *7	Trapezoid acceleration time					
	Unit	Default setting	Range	Suitable mode	Modify	Effective
	1ms	0	0~65535	5	Servo OFF	Immediately
The time accelerating from 0 to rated speed						
P4-14+ (n-1) *7	Trapezoid deceleration time					
	Unit	Default setting	Range	Suitable mode	Modify	Effective
	1ms	0	0~65535	5	Servo OFF	Immediately
The time decelerating from rated speed to 0						
P4-15+ (n-1) *7	Reserved					
P4-16+ (n-1) *7	Adjust time					
	Unit	Default setting	Range	Suitable mode	Modify	Effective
	ms	0	0~65535	5	Servo OFF	Immediately

- Notes: 1. Set pulse number = pulse number (high bit) ×10000 + pulse number (low bit).
 2. In formula P4-10+(n-1)*7, n is the segment no. of internal position; the range is 1~35. Segment 1~12 can be set through the operate panel, segment 13~35 needs to write in parameters through communication (RS232 or RS485).
 3. If one of the segment speed is zero, servo will skip this segment and run the next segment.
 4. In relative positioning mode, if one segment speed is not zero but the pulse number is zero, the motor will not run, but the wait mode is effective. The servo will run the next segment when the adjust time is

out.

5. In absolute positioning mode, if one segment speed is not zero but the pulse number is zero, the motor will return to the reference origin with the speed of this segment.

6. In absolute positioning mode, if 2 consecutive segments speed are not zero, but the pulse number is the same, the servo motor will not run but the wait mode is effective.

The internal position has 35 segments. P4-04 can set the effective segment. For example, P4-04 set to 5 means segment 1~5 are effective.

Parameter	Function	Default setting	Range	Modify	Effective
P4-04	Effective segment	1	1~35	Servo OFF	Immediately

5-14-4. Change step (/CHGSTP)

Parameter	Signal	Type	Default	Meaning	Modify
P5-35	/CHGSTP	Input	n.0000	Need distribute	Range: 0000-0014. Distribute to input terminal through P5-35. When it set to 0001, it means input from S11.

Note: /CHGSTP can be distributed to other input terminal by setting the parameter P5-35. Refer to chapter 5-12-1.

5-14-5. Pause current segment signal (/INHIBIT)

Parameter	Signal	Default setting	Meaning	Modify
P5-32	/INHIBIT	n.0000	Stop the pulse input in position control mode. When /INHIBIT is ON, stop counting the pulses.	Range: 0000-0014. Distribute to input terminal through P5-32. When it set to 0001, it means input from S11.

/INHIBIT signal is distributed to I/O terminal via P5-32, refer to chapter 5-12-1.

5-14-6. Skip current segment signal (/ZCLAMP)

/Z-CLAMP signal	Change step mode	Execution
	0	Cancel current segment, execute the next segment at once
	1	Cancel current segment, execute the next segment when the change step signal is ON
	2	Cancel current segment, execute the next segment at once
	3	Cancel current segment, set the F2-09 again

Parameter	Signal	Default	Meaning	Modify
P5-31	/Z-CLAMP	n.0000	Need to distribute	Range: 0000-0014. Distribute to input terminal through P5-31. When it set to 0001, it means input from S11.

5-14-7. Reference origin

1. Find the reference origin

To find out the physical origin of working table and make it as the coordinates origin of point position control. Users can select finding reference origin at forward or reverse side.

Function setting:

P4-00 n.XX□X	Unit	Default	Range	Suitable mode	Modify	Effect
	-	0	0~1	5, 6	Servo OFF	Immediately

Note: P4-00=0, find reference origin function is invalid. P4-00=n.001x, this function is valid.

Signal setting:

Parameter	Signal	Default	Meaning	Modify
P5-28	/SPD-A	n.0000	Mode 3: internal speed selecting signal	Range: 0000-0014, distributes to input terminal through P5-28. When it set to 0001, it means input signal from S11.
			Mode 5/6: find origin point at forward direction	
P5-29	/SPD-B	n.0000	Mode 3: internal speed selecting signal	Range: 0000-0014, distributes to input terminal through P5-29. When it set to 0001, it means input signal from S11.
			Mode 5/6: find origin point at forward direction	

Related parameter setting:

P4-00 n.xxxx□	The quantity pass the Z phase signal after leaving the limit switch					
	Unit	Default	Range	Suitable mode	Modify	Effective
	1	2	1~F	5, 6	Servo OFF	Immediately
P4-01	The speed hitting the proximity switch					
	Unit	Default	Range	Suitable mode	Modify	Effective
	0.1rpm	600	0~50000	5, 6	Servo OFF	Immediately
P4-02	The speed leaving the proximity switch					
	Unit	Default	Range	Suitable mode	Modify	Effective
	0.1rpm	100	0~50000	5, 6	Servo OFF	Immediately

Detailed explanation:

Find reference origin diagram:

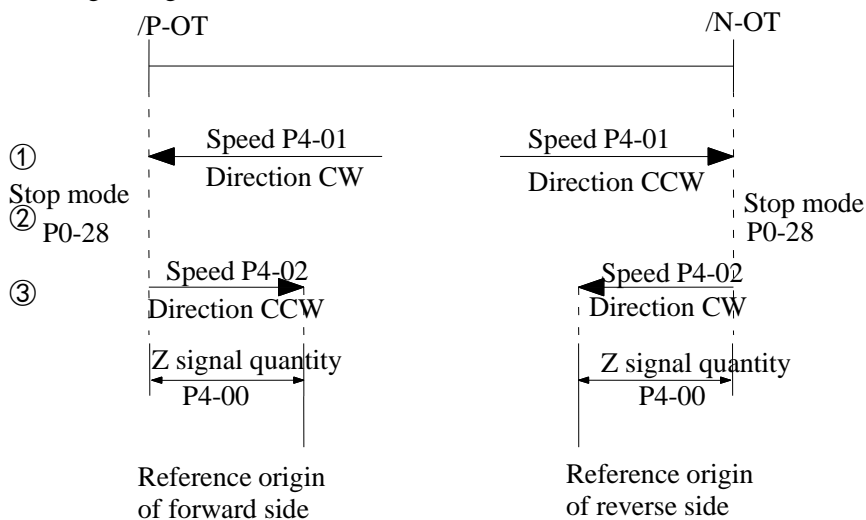

The timing diagram of finding reference origin of forward side:

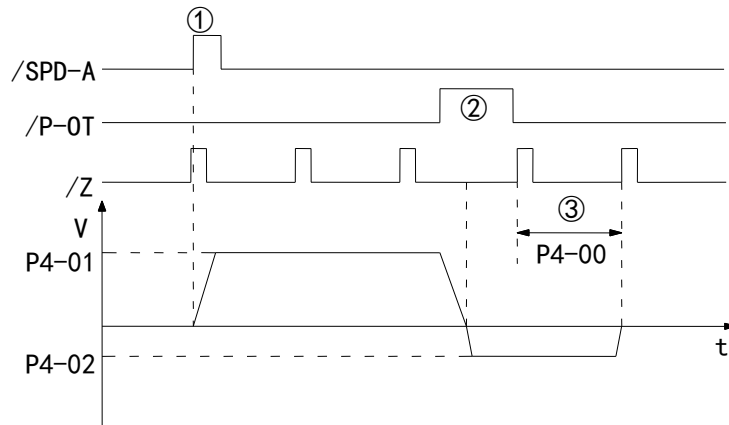

Steps:

- (1). Install limit switch at forward and reverse side. At the rising edge of /SPD-A, motor runs forward at the speed of P4-01 to find the reference origin of forward side.
- (2). After the working table hit the limit switch, the motor stop as the mode set by parameter P0-28
- (3). Motor leaves the limit switch at the speed of P4-02. After the working table left the limit switch, the motor run at the Z phase signal position of No.n optical encoder. This position is considered as the coordinates origin, n is decided by parameter P4-00.

2. Define the reference origin

Parameter	Signal	Default	Meaning	Modify
P5-27	/SPD-D	n.0000	Mode 1,2,3,4: not distribute to the terminal. To switch the rotation direction.	Range: 0000-0014. Distribute to input terminal through P5-27. When it set to 0001, it means input signal from S11.
			Mode 5,6: not distribute to the terminal. To define the current point to origin.	

5-14-8. Set segment through communication

F2-09	Unit	Default	Range	Suitable mode	Modify	Effective
	-	0	1~35	5	Servo OFF	Immediately

This parameter is set to certain segment, it will execute this segment. No need step change signal. This parameter can be changed through communication.
For example: execute segment 2. Set F2-09=0, then set F2-09=02.

5-14-9. Motion start signal (/MRUN)

Parameter	Signal name	Default setting	Meaning	Modification
P5-50	/MRUN	n.0000	Default setting is no terminal output. It is only valid in internal position mode, similar to positioning complete signal in external pulse mode. It will output when the motor is running, and will not output when the motor stop.	Range 0000-0013, it can be distributed to output terminal by P5-50. When it is set to 0001, means output signal from SO1.



the terminal function cannot repeat. Please refer to chapter 5-12-3.

6 Servo gain adjustment

6-1. Gain parameter adjustment

The servo system contains position loop, speed loop, current loop which are the core of servo system. The parameters related to the three loops are gain(K_p), the integral time constant(K_i), response level, filter time, feedforward gain, etc. These parameters determine the performance of the entire system. DS3 has two groups of gain parameters which can automatic switching. The switching condition can be set according to user requirements.

6-1-1. Gain parameters

Some parameters may not fit the system requirements after the external load changed. There are two groups of parameters for users.

Group one:

P1-00	First Speed loop gain (K_p)					
	Unit	Default	Range	Suitable mode	Modify	Effective
	1Hz	100	1~9999	3, 4, 6, 7, 10	Any	Immediately
P1-01	First Speed loop integral time constant (K_i)					
	Unit	Default	Range	Suitable mode	Modify	Effective
	0.1ms	400	0~10000	3, 4, 6, 7, 10	Any	Immediately

Speed loop gain

Speed loop gain:

To set the speed loop gain larger and the speed integral time constant smaller can realize high response speed controlling. But servo will restrict by machine performance. We suggest to increase or decrease the parameter by the unit of 5 or 10.

It will cancel the integral function when integral time constant is 0 or 10000. It will keep the integral when integral time constant is 9999.

P1-02	First Position loop gain (K_p)					
	Unit	Default	Range	Suitable mode	Modify	Effective
	1/s	100	1~9999	6, 10	Any	Immediately

Position loop gain

To do position control with high response and less offset needs to set the position loop gain larger. But servo will restrict by machine performance. We suggest to increase or decrease the parameter by the unit of 5 or 10.

P1-03	First speed feedback response level					
	Unit	Default	Range	Suitable mode	Modify	Effective
	Hz	1000	0~4000	All the modes	Any	Immediately
The larger the response level, the faster the response speed, but it will show vibration for low speed running, at this time please decrease P1-03.						
P1-04	First torque command filter time constant					
	Unit	Default	Range	Suitable mode	Modify	Effective
	0.01ms	0	0~9999	All the modes	Any	Immediately
Function: the larger the filter time, the smoother it is, but the response will delay						

Group two:

P1-05	Second Speed loop gain (Kp)					
	Unit	Default	Range	Suitable mode	Modify	Effective
	1Hz	100	1~9999	3, 4, 6, 7, 10	Any	Immediately
P1-06	Second Speed loop integral time constant (Ki)					
	Unit	Default	Range	Suitable mode	Modify	Effective
	0.1ms	400	0~10000	3, 4, 6, 7, 10	Any	Immediately

Speed loop gain

Speed feedback

To set the speed loop gain larger and the speed integral time constant smaller can realize high response speed controlling. But servo will restrict by machine performance.
It will cancel the integral function when integral time constant is 0 or 10000. It will keep the integral when integral time constant is 9999.

P1-07	Second Position loop gain (Kp)					
	Unit	Default	Range	Suitable mode	Modify	Effective
	1/s	100	1~9999	6, 10	Any	Immediately

P1-08	Second speed feedback response level					
	Unit	Default	Range	Suitable mode	Modify	Effective
	Hz	1000	0~4000	All the modes	Any	Immediately

The larger the response level, the slower the response speed, more stable

P1-09	Second torque command filter time constant					
	Unit	Default	Range	Suitable mode	Modify	Effective
	0.01ms	0	0~9999	All the modes	Any	Immediately
Function: the larger the filter time, the smoother it is, but the response will delay						

6-1-2. Other parameters

Speed feedforward:

P1-10	Speed feedforward gain (Kp)					
	Unit	Default set	Range	Suitable mode	Change	Effective
	1%	0	0~300	6, 10	Any	At once
Increase this parameter can improve the rigidity, but it maybe overshoot.						
P1-11	Speed feedforward filter time					
	Unit	Default set	Range	Suitable mode	Change	Effective
	0.01ms	50	0~10000	6, 10	Any	At once

Torque feedforward:

P1-12	Torque feedforward gain (Kp)					
	Unit	Default set	Range	Suitable mode	Change	Effective
	1%	0	0~300	3, 4, 6, 7, 10	Any	At once
Increase this parameter can improve the rigidity, but it maybe overshoot.						
P1-13	Torque feedforward filter time					
	Unit	Default set	Range	Suitable mode	Change	Effective
	0.01ms	0	0~10000	3, 4, 6, 7, 10	Any	At once

6-2. Parameter switching

There are 6 switching modes for speed mode and position mode. It provides solution for the problem of external load changing but control parameters cannot change immediately.

Gain switching in position mode:

P1-14	Position gain switching mode					
	Unit	Default setting	Range	Suitable mode	Change	Effective
	—	0	0~6	6, 10	Any	At once
	mode	function	unit	Explanation		
	0	Group 1	—	Use group 1 parameters (P1-00~P1-04)		
	1	Group 2	—	Use group 2 parameters (P1-05~P1-09)		
	2	G-SEL signal	—	Choose the group through external terminal (chapter 6-2-1)		
	3	Torque command	% of rated	When torque command less than P1-16, use group 1; when torque command larger than P1-16, use group 2		
	4	Speed command	rpm	When speed command less than P1-16, use group 1; when speed command larger than P1-16, use group 2.		
	5	Position offset	1 command	When position offset less than P1-16, use group 1; when position offset larger than P1-16, use group 2.		
6	Speed feedback	rpm	When speed feedback less than P1-16, use group 1; when speed feedback larger than P1-16, use group 2.			
P1-16	Position gain switching comparison value					
	Unit	Default setting	Range	Suitable mode	Change	Effective
	Rated to P1-14 mode	50	-9999~9999	6, 10	Any	At once
P1-17	Position gain switching comparison value hysteresis loop					
	Unit	Default setting	Range	Suitable mode	Change	Effective
	Related to P1-14 mode	20	-9999~9999	6, 10	Any	At once
Note: hysteresis loop please refer to chapter 5-11-4						

Gain switching in speed mode:

P1-18	Speed gain switching mode					
	Unit	Default setting	Range	Suitable mode	Change	Effective
	—	0	0~6	3, 4, 7	Any	At once
	Mode	Function	Unit	Explanation		
	0	Group 1	—	Use group 1 parameters (P1-00~P1-04)		
	1	Group 2	—	Use group 2 parameters (P1-05~P1-09)		
	2	G-SEL signal	—	Choose the group through external terminal (chapter 6-2-1)		
	3	Torque command	% of rated	When torque command less than P1-20, use group 1; when torque command larger than P1-20, use group 2		
	4	Speed	rpm	When speed command less than P1-20, use group 1;		

		command		when speed command larger than P1-20, use group 2.			
	5	Position offset	1 command	When position offset less than P1-20, use group 1; when position offset larger than P1-20, use group 2.			
	6	Speed feedback	rpm	When speed feedback less than P1-20, use group 1; when speed feedback larger than P1-20, use group 2.			
P1-20	Speed gain switching comparison value						
	Unit		Default setting	Range	Suitable mode	Change	Effective
	Rated to P1-18 mode		50	-9999~9999	3, 4, 7	Any	At once
P1-21	Speed gain switching comparison value hysteresis loop						
	Unit		Default setting	Range	Suitable mode	Change	Effective
	Related to P1-18 mode		20	0~9999	3, 4, 7	Any	At once
Note: hysteresis loop please refer to chapter 5-11-4							

6-2-1. G-SEL signal input

When the gain switching mode is 2, it can switch the parameter through /G-SEL input signal.

Parameter	Signal	Type	Default	Meaning	Suitable mode	Modify	Effective
P5-33	/G-SEL	Input	n.0000	Need to distribute	All the modes	Any	At once
/G-SEL can be distributed to input terminal via parameter P5-33. Refer to chapter 5-12-1.							

Function realization:

Input signal	Signal state	Gain group
/G-SEL	0	Group 1
	1	Group 2
Note: the 0, 1 is signal state but not terminal state.		

6-3. The experience of gain adjustment

First, it is important to know the mechanical structure. Common synchronous machine with driving has less rigidity, decrease the servo rigidity to match it. Large inertia mechanical system has long response time, it needs to decrease the servo rigidity and set more acceleration/deceleration time for speed command. For the mechanical system with small load inertia and strong rigidity such as coupling, it needs to increase the servo rigidity to improve the positioning efficiency.

Servo parameter adjustment method in position mode for typical mechanical system:

(1) Mechanical system: synchronous with coupling, large load inertia.

Servo system: decrease the rigidity, increase speed loop integral time (P1-01), decrease the position loop gain (P1-02). If the response is not enough after adjusting, increase the speed loop gain (P1-00).

Typical setting: P1-00=100, P1-01=1000, P1-02=50.

(2) Mechanical system: synchronous with coupling, small load inertia and load torque.

Servo system: follow the default parameter.

(3) Mechanical system: rigidity coupling, large load inertia.

Servo system: same to (1).

Typical setting: P1-00=100, P1-01=1000, P1-02=80.

(4) Mechanical system: rigidity coupling, small load inertia, strong rigidity.

Servo system: P1-00=100, P1-01=300, P1-02=150. If it cannot meet the requirements, please increase the position loop feedforward, for example set P1-10 to 20.

Note: above typical settings only show the direction to adjust the parameters. The settings cannot be suitable for all the conditions.

7 Specification and dimension

7-1. Servo motor

7-1-1. Servo motor specification

Please refer to this chapter when selecting the servo drive.

Voltage level		220V							
Motor type MS-		40ST-	60ST-				80ST-		
		M00330	M00630	M01330		M02430			
		□□-20P1	□□-20P2	□□-20P4		□□S-20P4	□□S-20P7	□□-20P7	
Motor code		1002	1003	0004	1004	F004	F011	1011	0011
Rated power (KW)		0.1	0.2	0.4	0.4	0.4	0.75		
Rated current (A)		1.8	1.8	2.5	2	2.5	3.5	3.2	3.0
Rated speed (rpm)		3000	3000	3000	3000	3000	3000	3000	3000
Max speed (rpm)		4000	4000	4000	4000	5000	5000	4000	4000
Rated torque (N m)		0.32	0.637	1.27	1.27	1.27	2.4	2.39	2.39
Peak torque (N m)		0.96	1.91	3.8	3.8	3.82	7.2	7.1	7.1
Back EMF constat (V/krpm)		11	26	28	162	36	36	56.6	48
Torque coefficient (N m/A)		0.18	0.37	0.5	0.68	0.51	0.51	0.92	0.8
Rotor inertia (Kg m ²)		0.04× 10 ⁻⁴	0.18× 10 ⁻⁴	0.438× 10 ⁻⁴	0.53× 10 ⁻⁴	0.34× 10 ⁻⁴	1.08× 10 ⁻⁴	1.05× 10 ⁻⁴	1.82× 10 ⁻⁴
Winding resistor (Ω)		3.4	3.5	3.49	3.8	2.9	2.9	2.7	2.88
Winding inductance (mH)		2.7	8.32	8.47	11.51	10.4	10.4	6.25	6.4
Electrical time constant (ms)		0.8	2.38	2.4	3.03	3.6	3.6	2.3	2.22
Weight (Kg)		0.55	1.1	1.78	1.72	1.3	2.6	2.87	2.86
Encoder ppr (PPR)		2500							
Pole pairs		4							
Motor insulation level		Class B (130°C)							
Protection level		IP65							
Ambient	Temperature	-15°C~+40°C							
	Humidity	Relative humidity < 90% (no condensation)							

Voltage level		220V							
Motor type MS-		80ST-	90ST-	110ST-		130ST-			
		M03520	M02430	M04030	M05030	M04030	M10010	M06025	
		□□-20P7		□□-21P2	□□-21P5	□□-21P2	□□-21P0	□□-21P5	
Motor code		0012	0021	0031	0032	1031	1040	0042	1042
Rated power (KW)		0.75	0.75	1.2	1.5	1.2	1.0	1.5	1.5

Rated current (A)	3.0	3.0	5.0	6.0	6.7	6.2	6.0	7.4
Rated speed (rpm)	2000	3000	3000	3000	3000	1000	2500	2500
Max speed (rpm)	2500	4000	3500	3500	4000	2000	3000	3000
Rated torque (N m)	3.5	2.4	4	5	4	10	6	6
Peak torque (N m)	10.5	7.1	12	15	10	30	18	18
Back EMF constat (V/krpm)	71	51	54	62	33	106.7	65	82
Torque coefficient (N m/A)	1.17	0.8	0.8	0.83	0.54	1.612	1.0	0.81
Rotor inertia (Kg m ²)	2.63×10 ⁻⁴	2.45×10 ⁻⁴	0.54×10 ⁻³	0.63×10 ⁻³	0.54×10 ⁻³	1.105×10 ⁻³	1.26×10 ⁻³	0.84×10 ⁻³
Winding resistor (Ω)	3.65	3.2	1.09	1.03	2.6	1.02	1.21	0.7
Winding inductance (mH)	8.8	7.0	3.3	3.43	12	3.57	3.87	5.07
Electrical time constant (ms)	2.41	2.19	3.03	3.33	4.62	3.5	3.2	7.24
Weight (Kg)	3.7	3.4	5.5	6.1	5.9	8.434	8.9	7.2
Encoder ppr (PPR)	2500							
Pole pairs	4							
Motor insulation level	Class B(130°C)							
Protection level	IP65							
Ambient	Temperature	-15°C~+40°C						
	Humidity	Relative humidity < 90% (no condensation)						

Voltage level	220V				
Motor type MS-	130ST-				
	M10015		M07725	M15015	M10025
	□□-21P5		□□-22P0	□□-22P3	□□-22P6
Motor code	0044	1044	0043	0046	0045
Rated power (KW)	1.5	1.5	2.0	2.3	2.6
Rated current (A)	6.0	8.0	7.5	9.5	10.0
Rated speed (rpm)	1500	1500	2500	1500	2500
Max speed (rpm)	2000	2000	3000	2000	3000
Rated torque (N m)	10	10	7.7	15	10
Peak torque (N m)	25	25	22	30	25
Back EMF constat (V/krpm)	103	61	68	114	70
Torque coefficient (N m/A)	1.67	1.25	1.03	1.58	1.0
Rotor inertia (Kg m ²)	1.94×10 ⁻³	1.272×10 ⁻³	1.53×10 ⁻³	2.77×10 ⁻³	1.94×10 ⁻³
Winding resistor (Ω)	1.29	0.3	1.01	1.10	0.73
Winding inductance (mH)	5.07	1.29	2.94	4.45	2.45
Electrical time constant (ms)	3.93	4.3	2.91	4.05	3.36
Weight (Kg)	11.5	9.34	10.0	14.4	9.8
Encoder ppr (PPR)	2500				

Pole pairs		4
Motor insulation level		Class B(130°C)
Protection level		IP65
Ambient	Temperature	-15°C~+40°C
	Humidity	Relative humidity < 90% (no condensation)

Voltage level		380V				
Motor type MS-	110ST-		130ST-			
	M04030	M05030	M06025	M10015		M07725
	□□-41P2	□□-41P5	□□-41P5			□□-42P0
Motor code	0131	0132	0142	0144	2144	1143
Rated power (KW)	1.2	1.5	1.5	1.5	1.5	2.0
Rated current (A)	3.0	3.9	3.7	3.5	5.6	6.4
Rated speed (rpm)	3000	3000	2500	1500	1500	2500
Max speed (rpm)	3500	3500	3000	2000	2000	3000
Rated torque (N m)	4	5	6	10	10	7.7
Peak torque (N m)	12	15	18	25	20	19.25
Back EMF constat (V/krpm)	89	90	110	177	61	61
Torque coefficient (N m/A)	1.33	1.11	1.62	2.86	1.25	1.2
Rotor inertia (Kg m ²)	0.54×10 ⁻³	0.63×10 ⁻³	1.26×10 ⁻³	1.94×10 ⁻³	1.272×10 ⁻³	1.272×10 ⁻³
Winding resistor (Ω)	3.30	2.28	3.50	4.37	0.3	0.3
Winding inductance (mH)	8.78	7.40	10.75	15.00	1.29	1.29
Electrical time constant (ms)	2.66	3.25	3.07	3.46	4.3	4.3
Weight (Kg)	5.5	6.1	8.9	11.5	9.34	9.34
Encoder ppr (PPR)	2500					
Pole pairs	4					
Motor insulation level	Class B(130°C)					
Protection level	IP65					
Ambient	Temperature	-15°C~+40°C				
	Humidity	Relative humidity < 90% (no condensation)				

Voltage level		380V			
Motor type MS-	130ST-		180ST-		
	M15015	M10030	M19015		M21520
	□□-42P3	□□-43P0	□□-43P0		□□-44P5
Motor code	1146	1148	0156	1052	0150
Rated power (KW)	2.3	3.0	3.0	3.0	4.5
Rated current (A)	7.3	6.4	7.5	7.8	9.5
Rated speed (rpm)	1500	3000	1500	1500	2000
Max speed (rpm)	2000	3500	2000	2000	3000
Rated torque (N m)	15	10	19	20	21.5
Peak torque (N m)	45	25	47	50	53
Back EMF constat (V/krpm)	124	88.3	158	138	140
Torque coefficient (N m/A)	2	1.56	2.53	2.56	2.26
Rotor inertia (Kg m ²)	2.44×10 ⁻³	1.13×10 ⁻³	3.8×10 ⁻³	2.8×10 ⁻³	4.7×10 ⁻³

Winding resistor (Ω)	1.8	0.46	1.15	0.67	0.71
Winding inductance (mH)	11.6	1.52	6.4	2.68	4.00
Electrical time constant (ms)	6.44	3.33	5.57	4.00	5.63
Weight (Kg)	11.1	11.4	20.5	17.1	22.2
Encoder ppr (PPR)	2500				
Pole pairs	4				
Motor insulation level	Class B(130°C)				
Protection level	IP65				
Ambient	Temperature	-15°C~+40°C			
	Humidity	Relative humidity < 90% (no condensation)			

Voltage level	380V					
Motor type MS-	180ST-				220ST-	
	M27015		M35015		M48015	M70015
	□□-43P3		□□-45P5		□□-47P5	□□-411P0
Motor code	2151	0151	1152	0152	0153	1157
Rated power (KW)	4.3	4.3	5.5	5.5	7.5	11.0
Rated current (A)	8.0	10.0	8.5	12.0	20.0	25
Rated speed (rpm)	1500	1500	1500	1500	1500	1500
Max speed (rpm)	2000	2000	2000	2000	2000	2000
Rated torque (N m)	27	27	35	35	48	70
Peak torque (N m)	54	67	87.5	70	96	105
Back EMF constat (V/krpm)	210	172	250	181	156	170
Torque coefficient (N m/A)	3.37	2.7	4.1	2.92	2.4	2.8
Rotor inertia (Kg m ²)	7.2×10 ⁻³	6.1×10 ⁻³	9.18×10 ⁻³	8.6×10 ⁻³	9.5×10 ⁻³	23.5×10 ⁻³
Winding resistor (Ω)	0.59	0.796	1.1	0.62	0.273	0.46
Winding inductance (mH)	14.4	4.83	15.1	4.0	2.14	5.54
Electrical time constant (ms)	24.4	6.07	13.7	6.45	7.84	12
Weight (Kg)	23.3	25.5	27.7	30.5	40.0	55.0
Encoder ppr (PPR)	2500					
Pole pairs	4					
Motor insulation level	Class B(130°C)					
Protection level	IP65					
Ambient	Temperature	-15°C~+40°C				
	Humidity	Relative humidity < 90% (no condensation)				

■ 40, 60, 80 and 90 series servomotors winding connector

Motor Winding connector	Winding Name	U	V	W	PE
	Connector	1	3	2	4

■ 40, 60, 80 and 90 series servo motor encoder connector

Signal	5V	0V	B+	Z-	U+	Z+	U-	A+	V+	W+	V-	A-	B-	W-	PE
Connector	2	3	4	5	6	7	8	9	10	11	12	13	14	15	1

■ 110, 130, 180 series servo motor winding connector

Motor Winding connector	Winding Name	U	V	W	PE
	Connector	2	3	4	1

■ 110, 130, 180 series servo motor encoder connector

Signal	5V	0V	A+	B+	Z+	A-	B-	Z-	U+	V+	W+	U-	V-	W-	PE
Connector	2	3	4	5	6	7	8	9	10	11	12	13	14	15	1

7-1-2. Torque-Speed Feature

A: continuous using area

B: repeated using area

MS-60ST-M00630□□-20P2

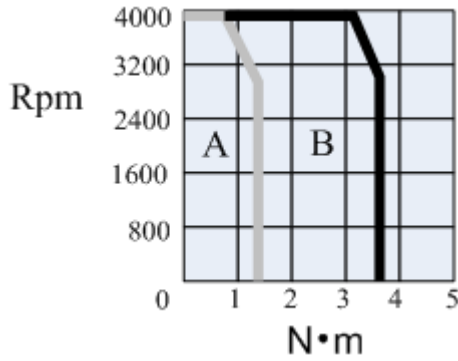

MS-60ST-M01330□□-20P4

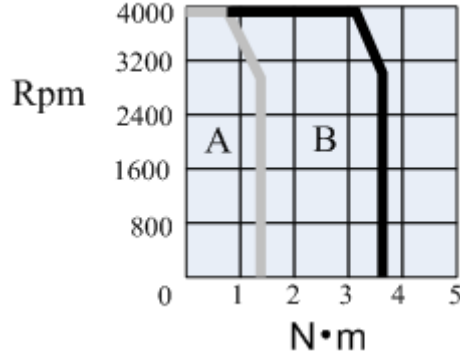

MS-80ST-M02430□□-20P7

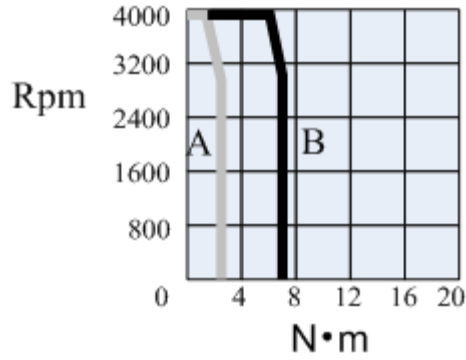

MS-90ST-M02430□□-20P7

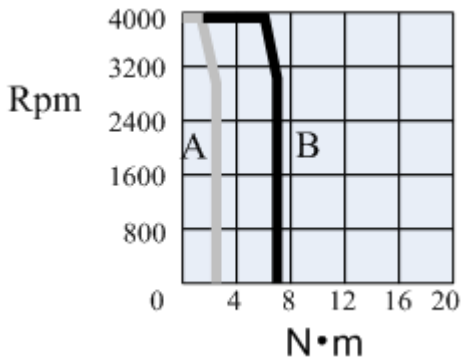

MS-110ST-M04030□□-21P2

MS-110ST-M04030□□-41P2

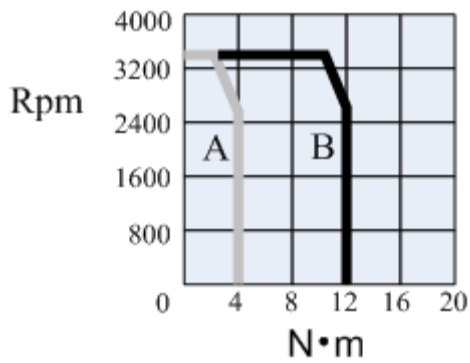

MS-110ST-M05030□□-21P5

MS-110ST-M05030□□-41P5

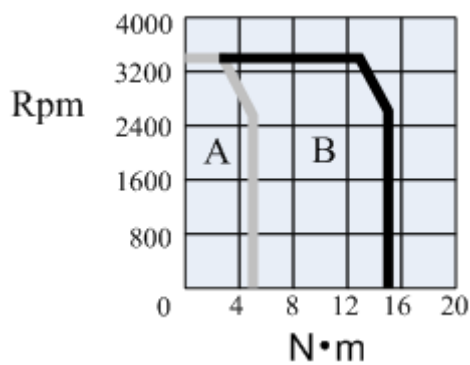

MS-130ST-M06025□□-21P5
MS-130ST-M06025□□-41P5

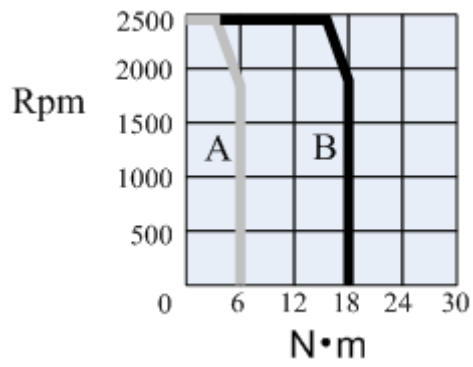

MS-130ST-M10015□□-21P5
MS-130ST-M10015□□-41P5

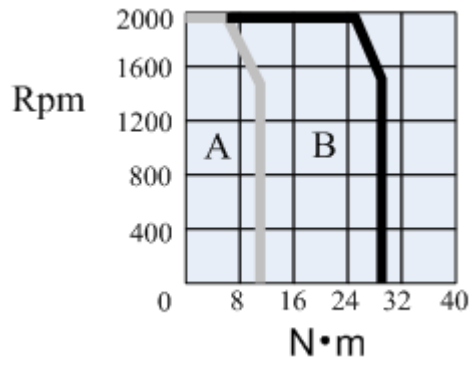

MS-130ST-M15015□□-22P3

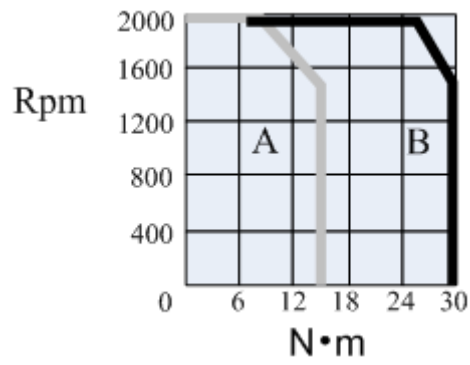

MS-130ST-M10030□□-43P0

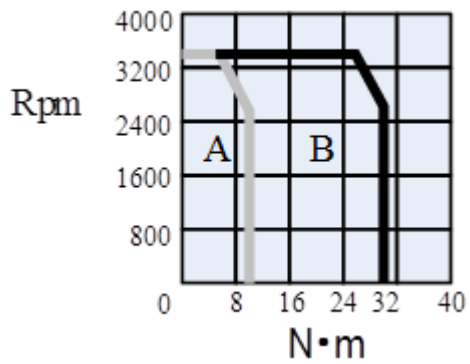

MS-180ST-M19015□□-43P0

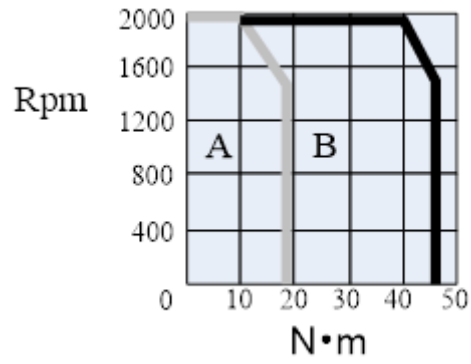

7-1-3. Servo motor dimensions

■ Dimensions of 40 series servo motors (unit: mm)

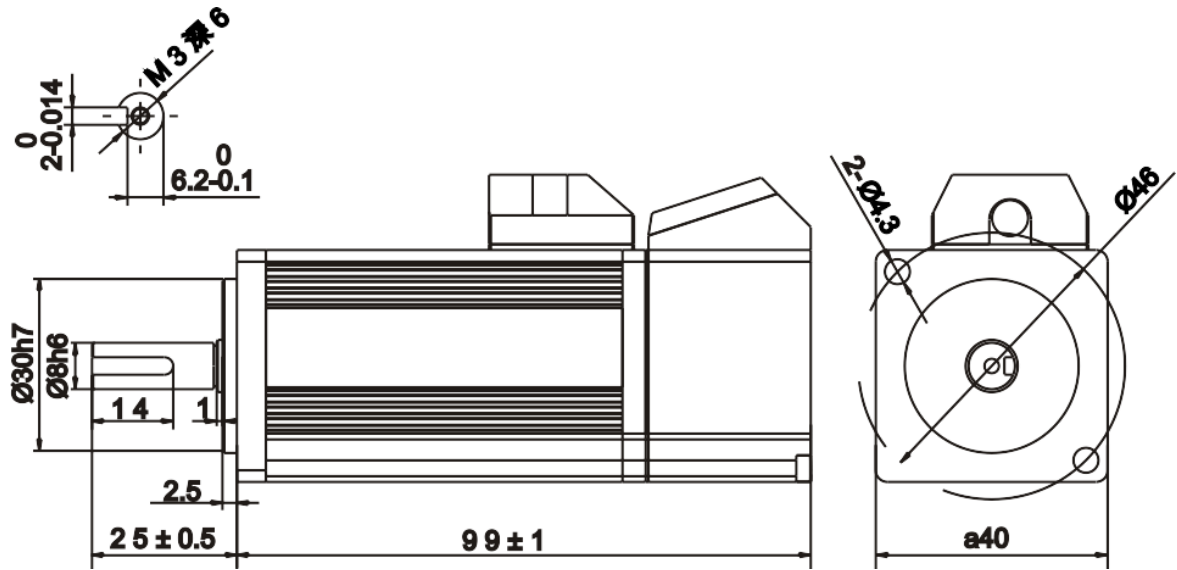

Motor type	LA	
	Normal	With brake
X2-40ST-M00330□□-20P1	99 ± 1	

■ Dimensions of 60 series servo motors (unit: mm)

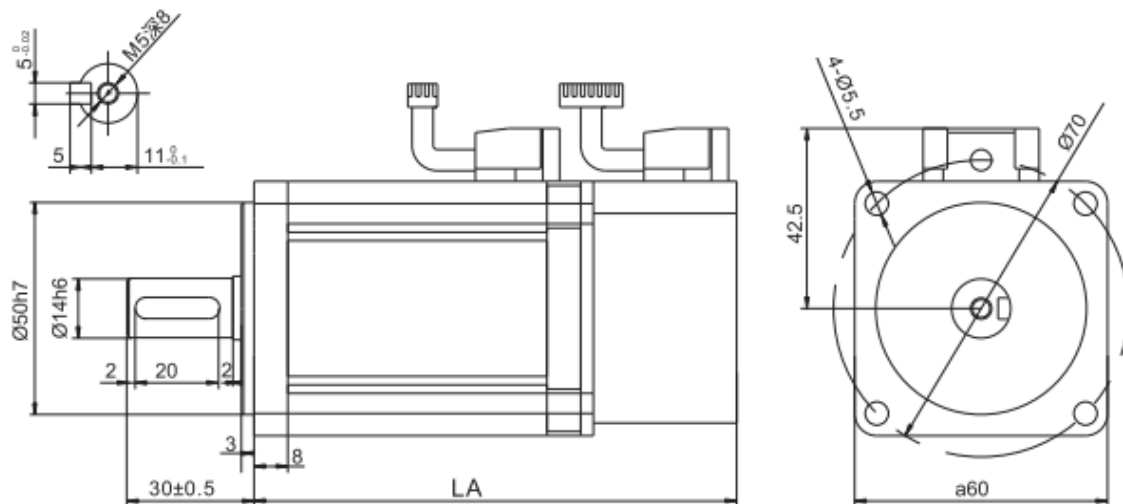

Motor type	LA	
	Normal	With brake
MS-60ST-M00630□□-20P2	115.5	159.5
MS-60ST-M00630□□S-20P2	90	127
MS-60ST-M01330□□-20P4	145	189
MS-60ST-M01330□□S-20P4	112	149
X2-60ST-M01330□□-20P4	133	-

■ Dimensions of 80 series servo motors (unit: mm)

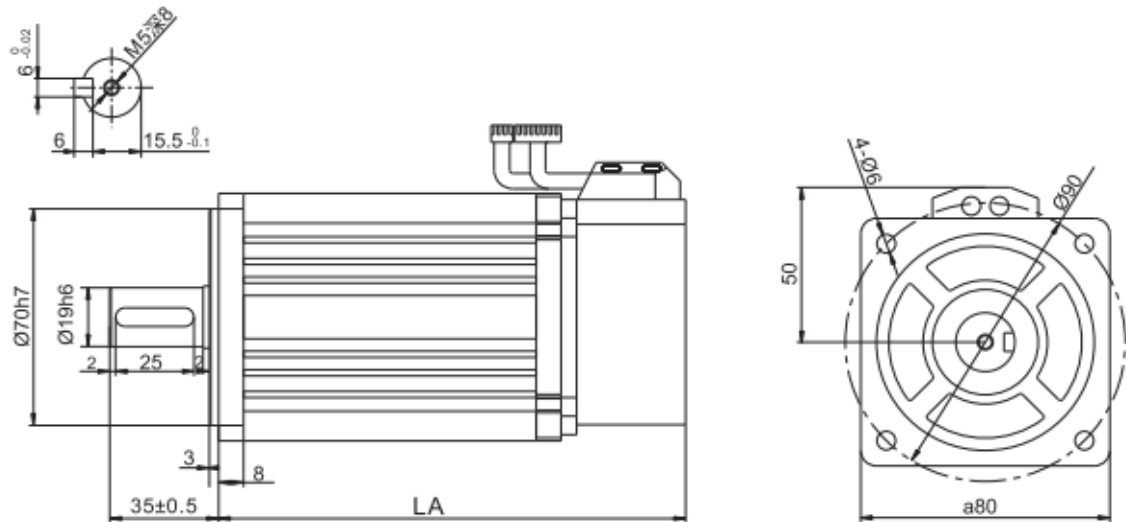

Type	LA	
	Normal	With brake
MS-80ST-M02430□□-20P7	150	199
MS-80ST-M03520□□-20P7	178	219
MS-80ST-M02430□□S-20P7	121	162
X2-80ST-M02430□□-20P7	151	-

■ Dimensions of 90 series servo motors (unit: mm)

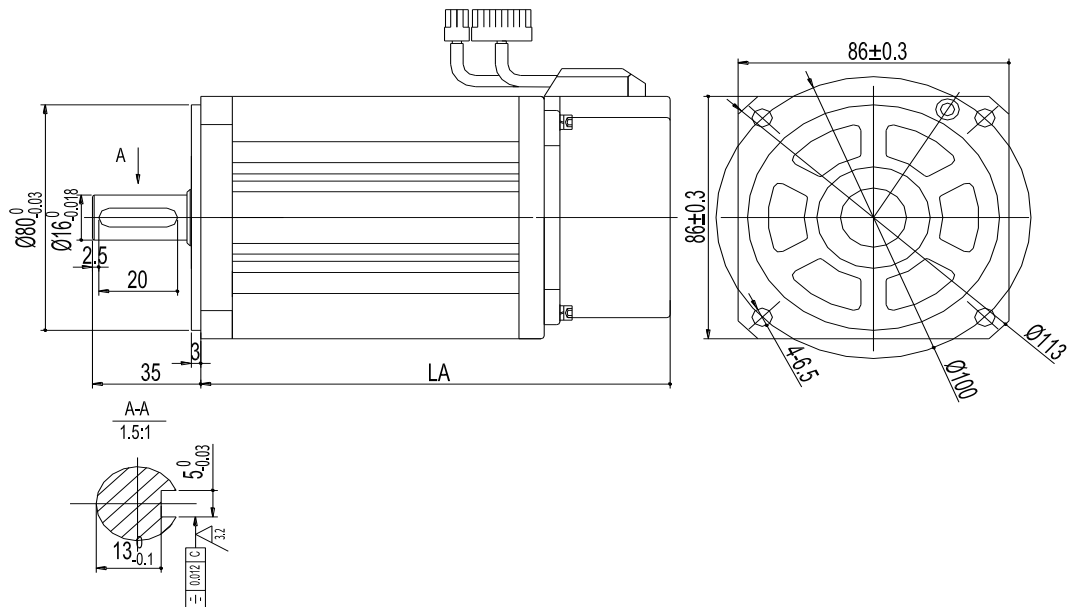

Type	LA	
	Normal	With brake
MS-90ST-M02430□□-20P7	149	194

■ Dimensions of 110 series servo motors (unit: mm)

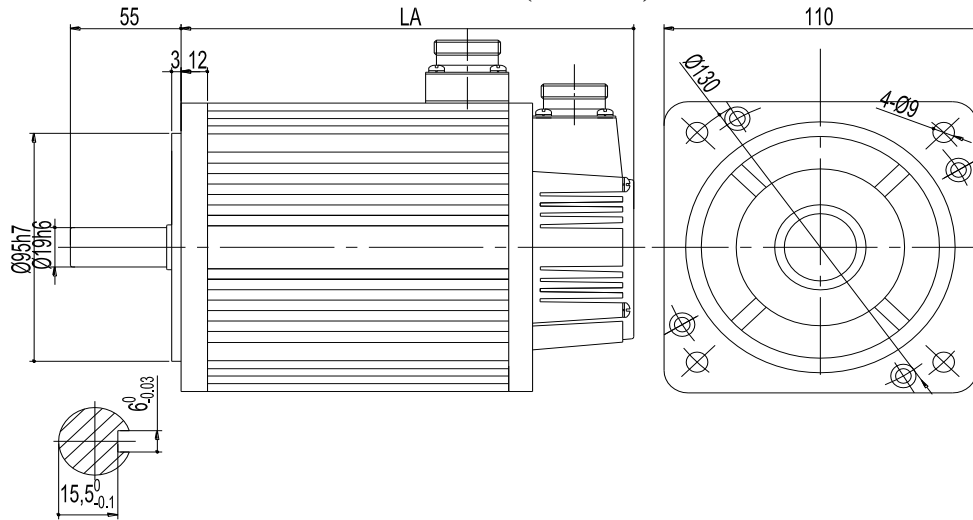

Type	LA	
	Normal	With brake
MS-110ST-M04030□□-21P2	189	263
MS-110ST-M04030□□-41P2		
MS-110ST-M05030□□-21P5	204	278
MS-110ST-M05030□□-41P5		

■ Dimensions of 130 series servo motors (unit: mm)

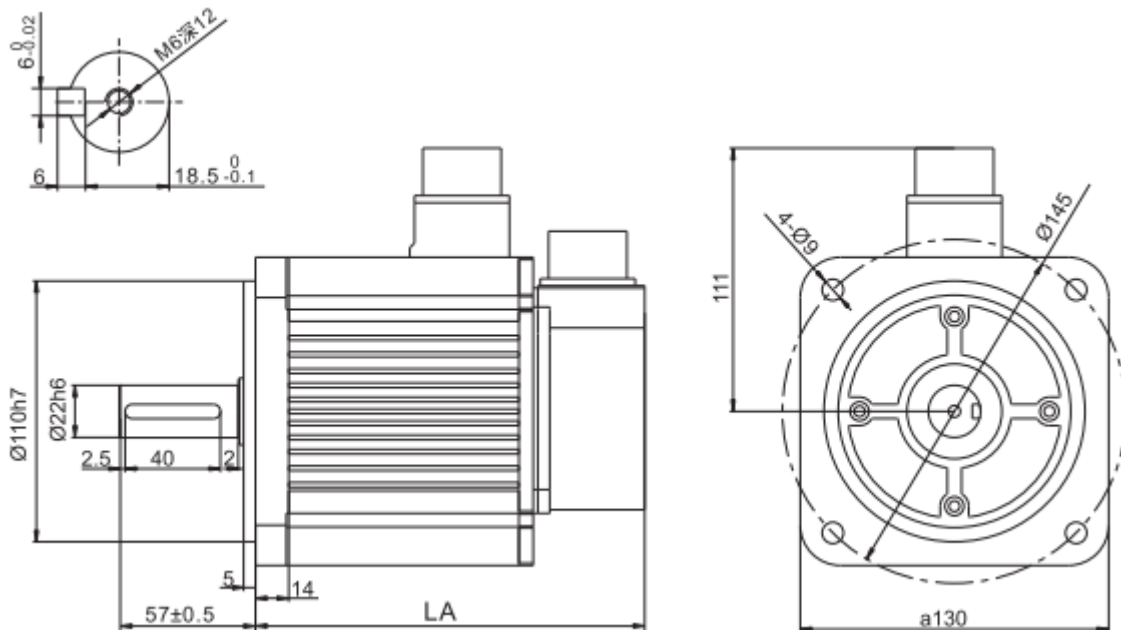

Motor type	Motor code	LA	
		Normal	With brake
MS-130ST-M04030□□-21P2	1031	165	-
MS-130ST-M10010□□-21P0	1040	194	265
MS-130ST-M06025□□-21P5	1042	180	239
	0042	179	236
MS-130ST-M10015□□-21P5	1044	206	265
	0044	213	294
MS-130ST-M07725□□-22P0	0043	192	249
MS-130ST-M15015□□-22P3	0046	241	322
MS-130ST-M15015□□-42P3	1146	226	285

MS-130ST-M06025□□-41P5	0142	179	263
MS-130ST-M10015□□-41P5	0144	213	294
	2144	206	265
MS-130ST-M10030□□-43P0	1148	230	289

■ Dimensions of 180 series servo motors (unit: mm)

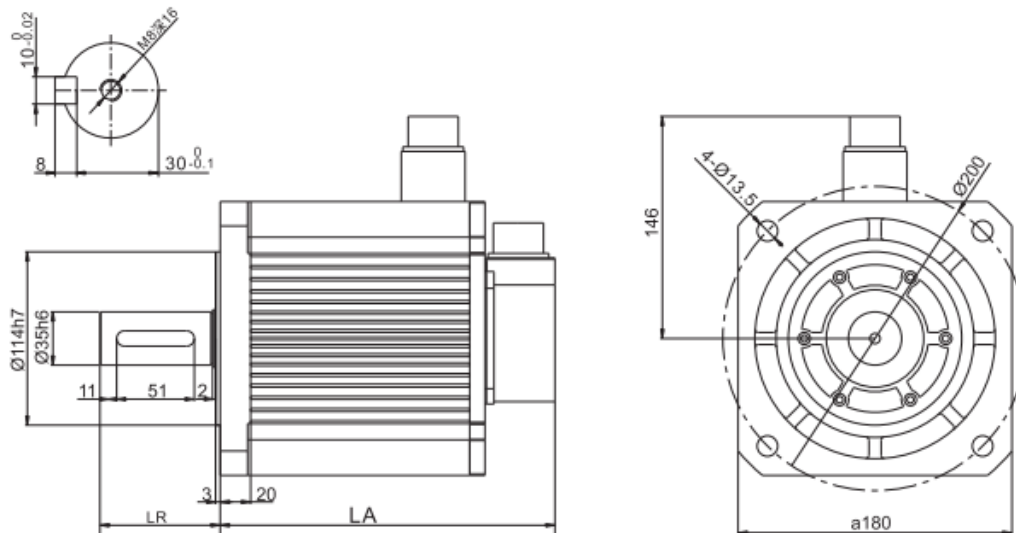

Motor type	Motor code	LR	LA	
			Normal	With brake
MS-180ST-M19015□□-43P0	1052	79	221	303
MS-180ST-M19015□□-43P0-S	0156	65	232	289
	1052	65	221	303
MS-180ST-M21520□□-44P5	0150	59	243	300
MS-180ST-M27015□□-44P3	1151/1161	79	247	329
MS-180ST-M27015□□-44P3-S	0151	65	262	319
	1151	65	247	329
MS-180ST-M35015□□-45P5	1152	79	277	359
MS-180ST-M35015□□-45P5-S	0152	59	292	349
	1152	59	277	359
MS-180ST-M48015□□-45P5	1153/1163	79	346	403

7-2. Servo drives

7-2-1. DS3E, DS3L, DS3-PTA, DS2 comparison table

Item		Fieldbus type	Pulse type	High precision type	Basic type	
		DS3E-□□ P □ -PFA	DS3L-□□ P □ -PFA	DS3-□□ P □ -PTA	DS2	
Basic specification	Power	0.1KW~3.0KW	0.1KW~3.0KW	0.4KW~1.5KW	0.1KW~11.0KW	
	Input power supply	Single phase/3-phase AC200~240V, 50Hz/60Hz 3-phase AC340V~440V, 50Hz/60Hz				
	Encoder feedback	2500ppr incremental encoder	2500ppr incremental encoder	17Bit absolute encoder	2500ppr incremental encoder	
	Control mode	Three phases full-wave rectifier IPM PWM control, sine-wave current drive mode				
	Using environment	Temperature	Running: 0°C~50 °C (no freezing)/ storage: -20°C~75 °C(no freezing)			
		Humidity	Running/storage: below 90% RH(no condensation)			
		Resistant to vibration and impact	4.9m/s ² / 19.6m/s ²			
	Function	Protection	Overvoltage, undervoltage, overheat, overcurrent, overload, overspeed, analog input error, position deviation too large, output short circuit, encoder error, regenerative error, overtravel			
		Dynamic brake	-			
		Communication function	RS232: ModbusRtu RS485: ModbusRtu, Xnet fieldbus (max 20 axes)	RS232: ModbusRtu	RS232: ModbusRtu RS485: ModbusRtu, Xnet fieldbus (max 20 axes)	RS232: ModbusRtu RS485: ModbusRtu
		Brake resistor	Internal brake resistor, can connect external brake resistor			
		Display and operate	5-bit LED light, power light, 4 buttons			
		Load rate of change	0~100% load: below ±0.1% (rated speed)			
		Voltage rate of change	Rated voltage ±10%: 0% (rated speed)			
		Temperature rate of change	20±25°C: below ±0.1% (rated speed)			
	Frequency features	250Hz (JL≤JM)				
I/O signal	Position output	Output mode	\	\	\	-AS/AS6: differential output -BS/BSW/AS2: no encoder feedback output
		Frequency deviation	\	\	\	\
		Collector Z phase output	\	\	support	support
	Analog input	\	\	\	-AS/AS6: 2 channels input (12 bits A/D) -BS/BSW/AS2: not support	
	Digital input	4 channels SI input	4 channels SI input	4 channels SI input	5 channels SI input	Servo enable, alarm clear, forward forbidden, reverse forbidden, torque limit option, internal speed option, gear ratio switch, mode switch, gain switch, pulse input forbidden, zero speed lock, position deviation clear, internal

			position step switch signal, internal control mode and direction switch			
	Digital output		2 channels SO output	2 channels SO output	2 channels SO output	3 channels SO output
		Positioning complete, servo ready, alarm output, torque limit output, same speed checking, rotating checking, speed reaching, brake release output, warning output				
Position control mode	Max input pulse frequency		Differential input: 500kpps Open collector: 200kpps			
	Pulse command mode		3.3V~24V pulse + direction, AB phase pulse		3.3V~24V pulse + direction, AB phase pulse	3.3V~24V pulse + direction, AB phase pulse CW/CCW signal
	Control mode		External pulse/internal position/motion fieldbus	External pulse/internal position	External pulse/internal position/motion fieldbus	External pulse/internal position
	Feedforward compensation		0~100% (resolution is 1%)			
	Positioning complete width setting		0~250 command unit (resolution is 1 command unit)			
	Electronic gear ratio		$1/100 \leq B/A \leq 100$			
Speed control mode	Control mode		Internal three-segment speed, external speed mode			Internal 3-segment speed, external analog, external speed mode
	Command smoothing mode		Low pass filter, smoothing filter			
	Analog input	Voltage range	\			-10V~+10V(resolution 12 bits)
		Input resistance	\			13K Ω
	Torque limit		Internal parameter	Internal parameter	Internal parameter	Internal parameter /external analog
	Speed rate of change		External load rated changing 0~100% load: below $\pm 0.01\%$ (rated speed)			
		Rated voltage $\pm 10\%$: 0.01% (rated speed)				
		Ambient temperature 20 $\pm 25^{\circ}\text{C}$: below $\pm 0.01\%$ (rated speed)				
Torque control mode	Control mode		Internal torque			Internal 3-segment speed, external analog
	Command smoothing mode		Low pass filter, smoothing filter			
	Analog input	Voltage range	\	\	\	-10V~+10V(resolution 12 bits)
		Input resistance	\	\	\	13K Ω
	Speed limit		Internal parameter	Internal parameter	Internal parameter	Internal parameter /external analog
Fieldbus control mode	Axis numbers		20 axes	\	20 axes	\
	Communication protocol		Xnet protocol	\	Xnet protocol	\

7-2-2. Servo drive dimensions

■ DS3L-20P1-PFB/ DS3L-20P2-PFB

(unit: mm)

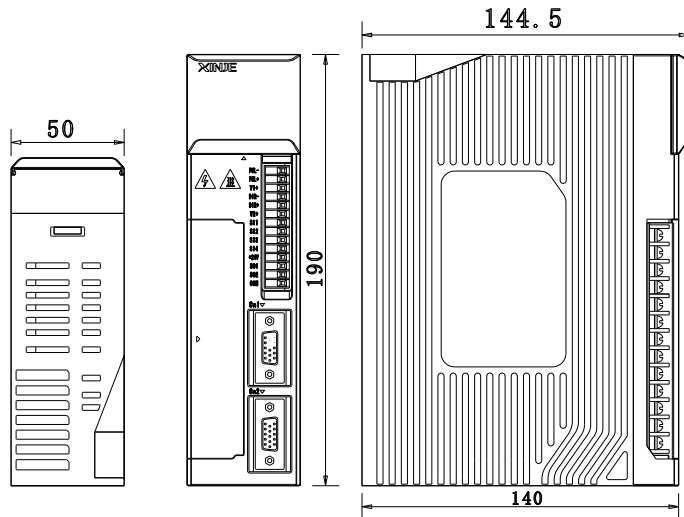

- DS3-20P1-PQA/ DS3-20P2-PQA/ DS3-20P4-PQA/ DS3-20P7-PQA
- DS3E-20P1-PFA/ DS3E-20P2-PFA/ DS3E-20P4-PFA/ DS3E-20P7-PFA
- DS3L-20P1-PFA/ DS3L-20P2-PFA/ DS3E-20P4-PFA/ DS3E-20P7-PFA
- DS3-20P2-PNA/ DS3-20P4-PNA/ DS3-20P7-PTA

Unit: mm

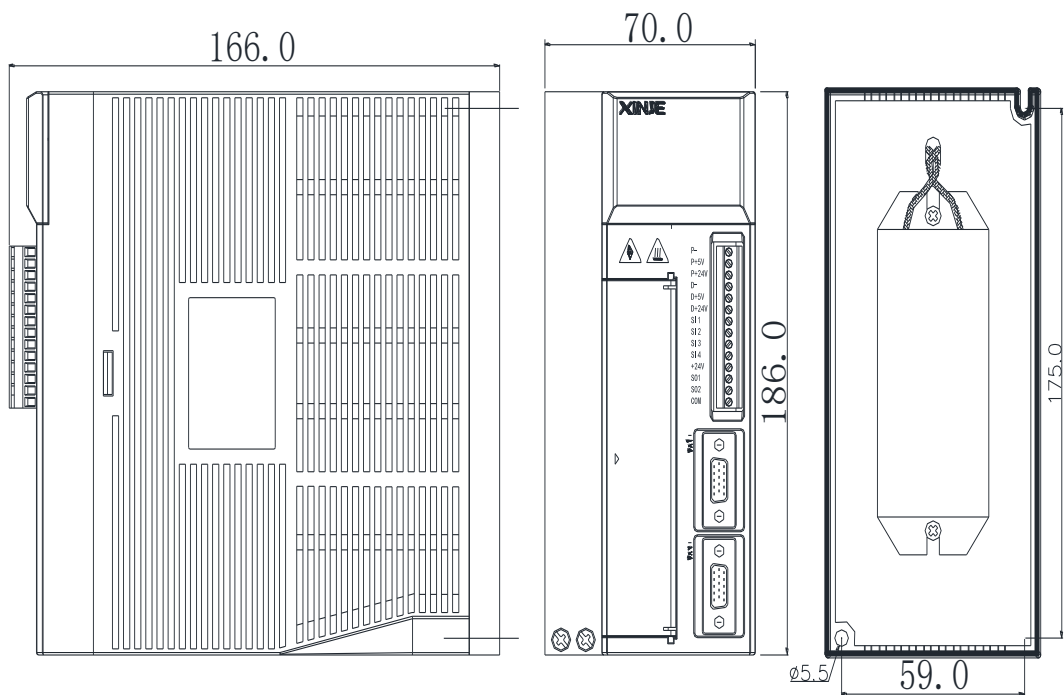

- DS3-21P5-PQA/ DS3-22P3-PQA/ DS3-41P5-PQA
- DS3E-21P5-PFA/ DS3E-22P3-PFA/ DS3E-22P6-PFA/ DS3E-41P5-PFA
- DS3L-21P5-PFA/ DS3L-22P3-PFA/ DS3L-22P6-PFA/ DS3L-41P5-PFA
- DS3-21P5-PTA/ DS3-22P3-PTA

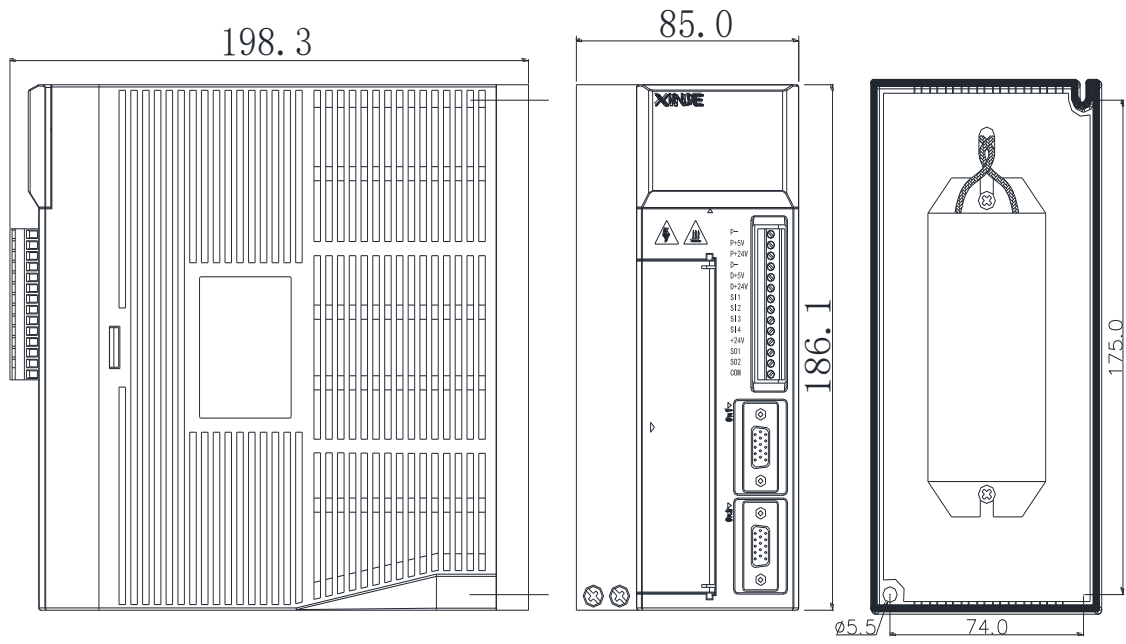

■ DS3-43P0-PQA / DS3E-43P0-PFA

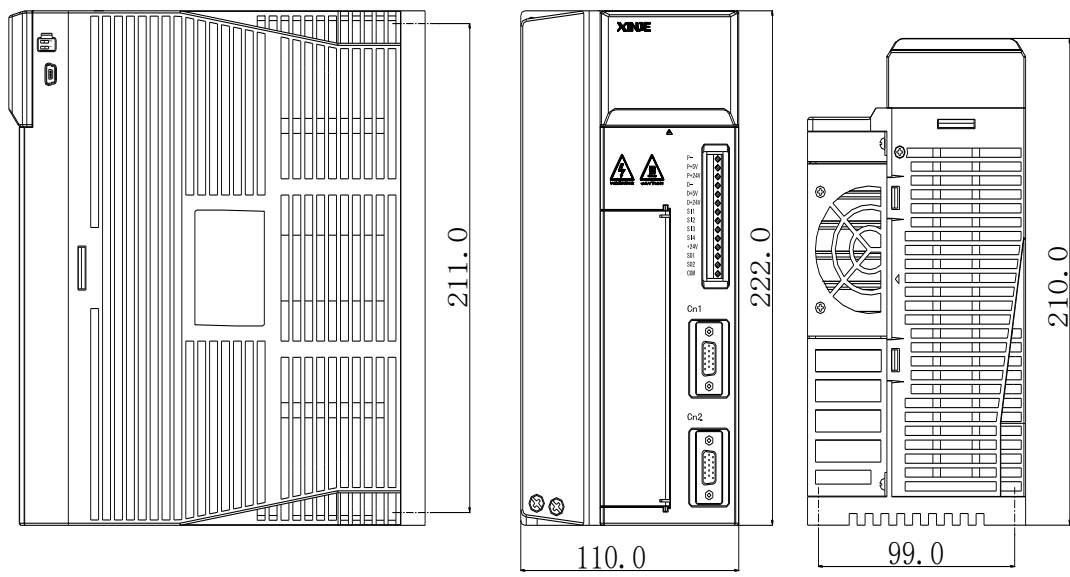

- DS3-45P5-PQA / DS3-47P5-PQA
- DS3L-45P5-PQA / DS3L-47P5-PQA

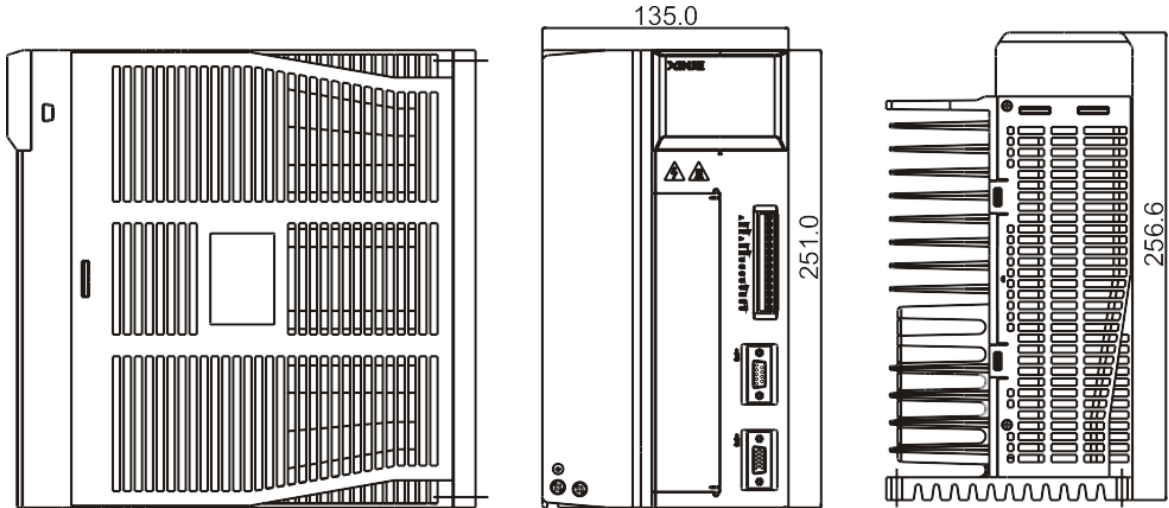

- DS3-411P-PQA / DS3-415P-PQA

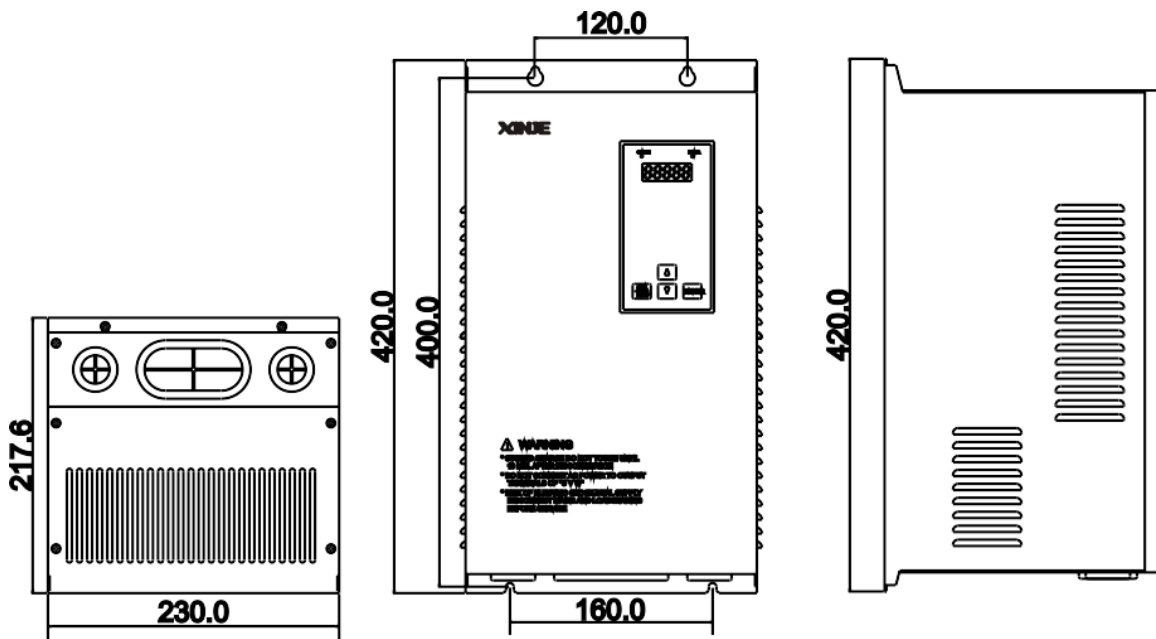

8 Alarm Information

DS3 series alarm code format is E-XX□, XX is main category, □ is sub categories.

XX	□	Alarm	Explanation	Reasons	Solution
01	0	E-010	Hardware version not match	The hardware version is error	Contact us
	2	E-012	System loading error	The program damaged	Contact us
	3	E-013	FPGA loading error	1. program damaged 2. hardware damaged	Contact us
	4	E-014	FPGA visiting error	1. program damaged 2. hardware damaged 3. external interference is too serious	Contact us
	5	E-015	Program running error	Program damaged	Contact us
	6	E-016	CPU running error	Hardware damaged	Contact us
	7	E-017	CPU running overtime	Program damaged	Contact us
	8	E-018	FPGA running overtime	Program damaged	Contact us
	9	E-019	System password error	Program damaged	Contact us
02	0	E-020	Parameter loading error	Parameter self-checking cannot pass	Re-power the servo to restore default setting or contact us
	1	E-021	Parameter out of range	The setting value out of range	Check the parameters and set again
	2	E-022	Parameter conflict	TREF or VREF function setting conflict	Check the TREF or VREF setting
	3	E-023	Sampling channel setting error	User-defined output trigger channel or data monitor channel setting error	Check the setting parameter
	4	E-024	Parameter lost	Power supply voltage too low	1.for single phase 220V, connect L1, L3 2. power on at once after cut power supply it will show E-024 3. set the parameter again
	5	E-025	Erase flash error	Parameter store error when power off	Contact us
	6	E-026	Initialize flash error	Flash chip power supply not stable	Contact us
03	0	E-030	Bus overvoltage (220V: $U_{0-05} \geq 390$ alarm, 380V: $U_{0-05} \geq 780$ V alarm)	power grid voltage too high	Check the power supply, 220V servo drive voltage range is 200V~240V, 380V servo drive voltage range is 360~420V, please use regulator and correct power supply
				Load inertia too large (regenerative ability not enough)	1. connect external regenerative resistor, please see below table for resistor value (220V: bus voltage $U_{0-05}=380$ start discharging, $U_{0-05}=350$ V discharge end.

					380V: U0-05=700 start discharging, U0-05=660 discharge end) 2. increase acceleration/deceleration time 3. decrease load inertia 4. decrease start/stop frequency 5. change larger power drive and motor
				regenerative resistor broken or value too big	Change suitable resistor, refer to chapter 3-4
				Load has locked rotor	Run the motor without load to check the problem
04	0	E-040	Bus undervoltage(220V: $U0-05 \leq 140$. 380V: $U0-05 \leq 300$)	Power grid voltage too low	1. Check the power grid, 220V servo drive voltage range 200~240V, please use regulator. 2. change large capacity transformer
				Instant cut power supply	Repower on after voltage is stable
	1	E-041	Drive power off	Drive power cut off	Check the power supply
	3	E-043	Bus voltage charging failure	Hardware damage	Please note if there is relay ON/OFF sound when drive power on
06	0	E-060	Module temperature too high	1. long time running with large load 2. environment temperature too high 3. short circuit between UVW	1. consider change the motor capacity(monitor U0-02, motor present torque) decrease the load 2. good ventilation, check if the fan is running when module temperature $U0-06 \geq 45^{\circ}\text{C}$ 3. check the UVW wiring
				1	E-061
		2	E-062	Drive too cold	Environment temperature is too low
07	0	E-070	Current too large	Not match the motor code	Drive P0-33 must match the motor code on the motor label
				U, V, W wiring error	Check the UVW wiring
				Encoder problem	1. Check encoder cable or change it 2. Set servo to bb state, monitor U0-10, rotate motor shaft by hand, U0-10 increase at one direction and decrease at another direction (0~9999)
				Short circuit with drive UVW or motor problem	1. measure the phase resistor of motor phase UVW, if not balanced, change the motor 2. If short circuit between UVW and PE, change the motor 3. Measure UVW output with multimeter (diode gear), black pen test P+, red pen test UVW, red pen test P-, black pen test UVW. 6. Group voltage any one is 0, change the drive
				Load has locked rotor	Run the motor without load to

					check the problem
				Interference	Shut down the device with interference
				Alarm at the moment of high-speed stop/start	Increase the acceleration time
08	0	E-080	Over speed(actual speed \geq P3-21/P3-22)	Motor speed too fast	1. check if there is external force make the motor over speed 2. input command frequency too high 3. electronic gear ratio too large
				Not match the motor code	Drive P0-33 must match the motor code on the motor label
				U, V, W wiring error with ground	Check the wiring
				Encoder problem	1. Check encoder cable or change it 2. Set servo to bb state, monitor U0-10, rotate motor shaft by hand, U0-10 increase at one direction and decrease at another direction (0~9999)
				Check P3-21/P3-22 max speed limit	When actual speed larger than P3-21/P3-22, it will alarm
		E-092	Analog Tref zero calibration over limit	Analog zero calibration operation error	Please not add analog value when calibrating
		E-093	Analog Vref zero calibration over limit	Analog zero calibration operation error	Please not add analog value when calibrating
10	0	E-100	Position offset too large	The difference between setting position and actual position is over the limit	1. check whether the motor stall, decrease the position setting speed 2. increase the offset pulse limit P0-23
11	0	E-110	Motor UVW short circuit	Not match the motor code	Drive P0-33 must match the motor code on the motor label
				U, V, W wiring error	Check UVW phase wiring
				Short circuit with drive UVW or motor problem	1. measure the phase resistor of motor phase UVW, if not balanced, change the motor 2. If short circuit between UVW and PE, change the motor 3. Measure UVW output with multimeter (diode gear), black pen test P+, red pen test UVW, red pen test P-, black pen test UVW. 6. Group voltage any one is 0, change the drive
				Load has locked rotor	Run the motor without load to check the problem
				Alarm at the moment of high-speed stop/start	Increase the acceleration time
				Encoder problem	1. Check encoder cable or change it 2. Set servo to bb state, monitor U0-10, rotate motor shaft by hand, U0-10 increase at one direction and decrease at another direction (0~9999)

12	0	E-120	Current sensor error	Current sensor damaged or external interference too large	Check the ground wiring or contact us
	1	E-121	U phase current sampling zero calibration value error	Current sensor damaged or external interference too large	Check the ground wiring or contact us
	2	E-122	V phase current sampling zero calibration value error	Current sensor damaged or external interference too large	Check the ground wiring or contact us
13	0	E-130	Motor quadrature encoder AB or UVW broken circuit	AB or UVW broken circuit	Cut off the drive power, Check the wiring, then repower the drive
14	2	E-142	Motor encoder Z phase disconnected	Z phase disconnected	Cut off the drive power, Check the wiring, then repower the drive
15	0	E-150	Motor encoder UVW phase disconnected	UVW phase disconnected	Check the wiring of UVW
16	0	E-160	Motor output power overload	Motor output power over the rated power	1. Change larger power motor 2. Check the motor shaft wiring
	1	E-161	The heating power overload	Motor overheating	1. Change larger power motor 2. Check the motor shaft wiring
	4	E-164	The bus capacitor overload	Power supply not stable, motor load too large, cause the bus capacitor charge frequently	1. use 3 phase 220V power supply for 220V drive 2. change larger power motor
	5	E-165	locked rotor alarm (drive version U2-23=12.24&750 W and down model support)	Locked rotor time up to P0-70(unit is second) and motor speed lower than P0-71(unit is 1rpm), motor present output torque larger than P3-28, P3-29	1. monitor U0-02 motor torque, check if P3-28, P3-29 torque limit value is reasonable 2. check the mechanical structure
17	0	E-170	Motor undervoltage when running	Bus voltage too low when running	1. check the power grid voltage fluctuation 2. wait the bus voltage stable, then repower
20	0	E-200	Regenerative resistor overload	Regenerative resistor discharging power over the rated	Change larger power regenerative resistor
	1	E-201	Regenerative resistor discharge too long time	Regenerative resistor connection error or value too large	Change small value resistor and check the wiring
22	0	E-220	Absolute encoder communication error	1. Encoder not connect or contactor not good	Cut off drive power, check encoder wiring, use multi-meter test the connection
				2. recived encoder data error, and error time over encoder error time register P0-56 value	Not put the encoder wire together with the strong power supply cable, install filter at servo drive power supply input side, install magnet ring around encoder wire, far away from large noise equipment
	2	E-222	Absolute encoder battery voltage	The battery voltage is lower than 2.75V	Please change new battery when the servo power is on, the battery

			low		is no.5 3.6V
	3	E-223	Absolute encoder data visit alarm	Encoder problem, or power supply is not stable	Unplug the encoder cable without battery will alarm
	4	E-224	Absolute encoder overspeed	Large change of encoder data	Unplug the encoder cable without battery will alarm
26	0	E-260	Over range alarm	Check the over range signal and the over range mode is alarm	If it no need to alarm after over range, user can change the over range signal mode
	1	E-261	Over range signal connection error	1. motor run forward and encounter the reverse over range signal 2. motor run reverse and encounter the forward over range signal	Check the over range connection and over range terminal distribution
	2	E-262	Control stop over time	1. inertia too big 2. stop overtime too short 3. brake torque too small	1. decrease the inertia or use motor with brake 2. increase stop overtime P0-30 3. increase brake torque P3-32
28	0	E-280	Vibration too serious	Motor vibration too serious	Decrease servo position loop or speed loop gain, check the motor shaft connection
30	0	E-300	Motion bus lose synchronization	Motion bus communication error	Check the motion bus connection
31	0	E-310	Motor code error	Motor code error	Set the correct motor code
	1	E-311	Motor code lost	Motor code not set	Set motor code in P0-33

The following table is regenerative resistor specification of each drive:

Servo drive	Min resistor	External regenerative resistor (recommended value)	External regenerative resistor (recommended power)
DS3-20P2-PQA DS3E-20P2-PFA DS3L-20P2-PFA DS3-20P2-PTA	50Ω	50Ω—100Ω	200W and up
DS3-20P4-PQA DS3E-20P4-PFA DS3L-20P4-PFA DS3-20P4-PTA	40Ω	40Ω—100Ω	500W and up
DS3-20P7-PQA DS3E-20P7-PFA DS3L-20P7-PFA DS3-20P7-PTA	40Ω	40Ω—100Ω	500W and up
DS3-21P5-PQA DS3E-21P5-PFA DS3L-21P5-PFA DS3-21P5-PTA	25Ω	25Ω—50Ω	1000W and up
DS3-22P3-PQA DS3E-22P3-PFA DS3L-22P3-PFA DS3-22P3-PTA	55Ω	25Ω—50Ω	1000W and up
DS3-41P5-PQA DS3E-41P5-PFA	55Ω	55Ω—100Ω	1000W and up

DS3L-41P5-PFA DS3-41P5-PTA			
DS3-43P0-PQA DS3E-43P0-PFA DS3L-43P0-PFA DS3-43P0-PTA	25Ω	55Ω—75Ω	1000W and up

Note:

- (1) the regenerative resistor value is better close to the min resistor value. The resistor power depends on the actual condition and heating power.
- (2) The frequent discharging of regenerative resistor make the temperature too high, please use high temperature resistant and flame retardant cable, and the surface of regenerative resistor cannot touch the cable.

Appendix 1 Parameter list

○ means the parameter can be modified when the servo is OFF, and effective when servo is ON.

● means the parameter can be modified any time, and effective when re-power on the servo.

√ means the parameter can be modified any time, and effective immediately.

Adding “n.” before the parameter means the value is hex.

Parameter: PX—XX= n.××××

PX—XX.H ← | → PX—XX.L

P0: function selection

P0-	Function	Unit	Default	Range	Effective	Suitable mode	Chapter
01	Submode 1 1: torque (command) (for DS3-PQA) 3: speed (command) 4: speed (analog) (for DS3-PQA) 5: position (internal) (for DS3E/DS3L) Note: hardware versoin v3.2.1 and above support this mode 6: position (pulse) 7: speed (pulse) 10: fieldbus position mode (for DS3E)	-	6	1~10	○	All the modes	5-1
02	Submode 2 1: torque (command) 2: torque (analog) (for DS3-PQA) 3: speed (command) 4: speed (analog) (for DS3-PQA) 5: position (internal) (for DS3E/DS3L) Note: hardware versoin v3.2.1 and above support this mode 6: position (pulse) 7: speed (pulse) 10: fieldbus position mode (for DS3E)	-	0	1~10	○	All the modes	5-1
03	Enable mode: 0: not enable 1: IO/SON input signal 2: software enable(panel/Modbus) panel F1-05 write in 1; Modbus write 1 to register 0x2105. Write 0 cancel enable. 3: bus enable (support motion bus model)	-	1	0~3	○	All the modes	5-2-1
05	Rotation direction selection	-	0	0, 1	○	All the modes	5-2-2
09	Input pulse command positive direction	-	0	0-1	○	6, 7	5-3-2
10 xxx□	0: CW/CCW 1: AB 2: P+D	-	2	0~2	○	6, 7	5-3-2
10 xx□x	0: falling edge is effective 1: rising edge is effective	-	0	0~1	○	6, 7	5-3-2
11	Pulses per circle low bit×1	-	0	0~9999	√	6	5-3-3
12	Pulses per circle high bit×10000	-	1	0~	√	6	5-3-3

				9999			
13	Numerator of Electronic gear ratio	-	1	1~ 65535	√	6	5-3-3
14	Denomination of electronic gear ratio	-	1	1~ 65535	√	6	5-3-3
15	Pulse frequency corresponding to speed mode rated speed	*100 Hz	1000	0~ 10000	○	7	5-6-3
16	Speed command pulse filter time	0.01ms	100	0~ 10000	○	7	5-6-4
18	Encoder feedback pulse per circle×1	1	2500	0~9999	○	All the modes	5-11-6
19	Encoder feedback pulse per circle×10000	10000	0	0~ 9999	○	All the modes	5-11-6
20	Encoder pulse frequency division (numerator)	-	1	0~ 65535	○	All the modes	5-11-6
21	Encoder pulse frequency division (denomination)	-	1	0~ 65535	○	All the modes	5-11-6
23	Pulse offset limit	*256 command unit	50000	0~ 65535	√	6	5-3-9
24	Discharge resistor type 0: internal 1: external	-	0	0~1	○	All the modes	3-4
25	Discharge resistor power	W	-	0~ 65535	√	All the modes	3-4
26	Discharge resistor value	Ω	-	0~ 500	√	All the modes	3-4
27	Servo OFF stop mode 0: inertia running stop, keep the inertia running state after stop 2: deceleration running stop, keep inertia running state after stop	-	0	0, 2	○	All the modes	5-2-3
28	Servo over range stop mode 0: deceleration stop, over range direction torque is 0 after stop, receive command 1: inertia stop, over range direction torque is 0 after stop, receive command 2: deceleration stop, over range direction not receive command after stop 3: alarm (E-260)	-	2	0~3	○	All the modes	5-2-3
29	Servo alarm stop mode 0: inertia stop, keep inertia running state after stop 2: deceleration stop, keep inertia running state after stop	-	0	0, 2	○	All the modes	5-2-3
30	Stop overtime time	0.1ms	20000	0~ 65535	○	All the modes	5-2-3
33	Motor code	-		0~ 65535	●	All the modes	4-7
70	Motor locked rotor time	s	0	0~9999	○	All the modes	
71	Motor locked rotor speed	rpm	0	0~9999	○	All the modes	

P1: control parameters

P1-	Name	Unit	Default	Range	Effective	Suitable mode	Chapter
00	The gain of first speed loop	Hz	100	1~9999	√	3,4,6,7,10	6-1-1
01	First speed loop integral time	0.1ms	400	0~10000	√	3,4,6,7,10	6-1-1
02	The gain of first position loop	1/s	100	1~9999	√	6, 10	6-1-1
03	First speed feedback response level	Hz	1000	0~4000	√	All the modes	6-1-1
04	First torque command filter time	0.01ms	0	0~9999	√	All the modes	6-1-1
05	Second speed loop gain	Hz	100	1~9999	√	3,4,6,7,10	6-1-1
06	Second speed loop integral time	0.1ms	400	0~10000	√	3,4,6,7,10	6-1-1
07	Second position loop gain	1/s	100	1~9999	√	6, 10	6-1-1
08	Second speed feedback response level	Hz	1000	0~4000	√	All the modes	6-1-1
09	Second torque command filter time	0.01ms	0	0~9999	√	All the modes	6-1-2
10	Speed Feedforward gain	1%	0	0~300	√	6, 10	6-1-2
11	Speed feedforward filter time	0.01ms	50	0~10000	√	6, 10	6-1-2
12	Torque feedforward	1%	0	0~300	√	3,4,6,7,10	6-1-2
13	Torque feedforward filter time	0.01ms	0	0~10000	√	3,4,6,7,10	6-1-2
14	Position gain switching mode 0: fixed the first group 1: fixed the second group 2: G-SEL signal 3: torque command 4: speed command 5: position offset 6: speed feedback	-	0	0~6	√	6, 10	6-2
16	Position gain switching comparison value	Related to the P1-14 mode	50	-9999~9999	√	6, 10	6-2
17	Position gain switching comparison value hysteresis loop	Related to the P1-14 mode	20	0~9999	√	6, 10	6-2
18	Speed gain switching mode 0: fixed the first group 1: fixed the second group 2: G-SEL signal 3: torque command 4: speed command 5: position offset 6: speed feedback	-	0	0~6	√	3, 4, 7	6-2
20	Speed gain switching comparison value	Related to the P1-18 mode	50	-9999~9999	√	3, 4, 7	6-2
21	Speed gain switching comparison value hysteresis loop	Related to the	0	0~9999	√	3, 4, 7	6-2

		P1-18 mode					
22	Speed command filter 0: first order low-pass filter 1: smoothing filter	-	0	0	√	3, 4, 7	5-4-9
23	Speed command filter time	0.1ms	0	0~65535	√	3, 4, 7	5-4-9
24	Position command filter 0: first order low-pass filter 1: smoothing filter	-	0	0~1	√	6, 10	5-3-4
25	Position command filter time	0.1ms	0	0~65535	√	6, 10	5-3-4

P2: parameters (reserved)

P3: speed control

P3-XX	Name	Unit	Default value	Range	Effective	Suitable mode	Chapter
00	V-REF function distribution 0: V-REF is speed command input 1: V-REF is external speed limit input, actual speed limit depend on external analog speed limit 2: speed feedforward	—	0	0~2	○	1, 2, 4, 6	5-4-2/ 5-7-5
01	Rated speed corresponding to analog voltage	0.01V	1000	150~3000	○	1, 2, 4, 6	5-4-2
02	Analog voltage speed filter	0.01ms	0	0~10000	√	1, 2, 4, 6	5-4-2
03	Speed command input dead area voltage	0.01v	0	0~100	√	1, 2, 4, 6	5-4-2
05	Preset speed 1	rpm	0	-9999~+9999	√	3	5-5-2
06	Preset speed 2	rpm	0	-9999~+9999	√	3	5-5-2
07	Preset speed 3	rpm	0	-9999~+9999	√	3	5-5-2
09	Acceleration time	ms	0	0~65535	○	3, 4	5-4-8
10	Deceleration time	ms	0	0~65535	○	3, 4	5-4-8
11	Reserved						
12	Zero speed clamp mode 0: ZCLAMP input signal is ON, forced speed command is 0. When the speed below P3-13, switch to position mode and the servo locked in this position 1: ZCLAMP input signal is ON, forced set speed command to 0 2: ZCLAMP input signal is ON, speed below P3-13 switch to position mode and the servo locked in this position	—	0	0~2	○	3, 4, 7	5-4-5
13	Zero speed clamp speed	rpm	10	0~10000	○	3, 4	5-4-5

14	Forward max speed command limit	rpm	Rated	30~10000	○	All the modes	5-4-2
15	Reverse max speed command limit	rpm	Rated	30~10000	○	All the modes	5-4-2
16	Internal forward speed limit in torque control mode	rpm	Related to the motor	30~10000	√	1, 2	5-7-5
17	Internal reverse speed limit in torque control mode	rpm	Related to the motor	30~10000	√	1, 2	5-7-5
18	Jog speed	rpm	100	0~1000	○	All the modes	4-4-2
19	Forward warning speed	rpm	Related to the motor	0~10000	○	All the modes	5-11-2
20	Reverse warning speed	rpm	Related to the motor	0~10000	○	All the modes	5-11-2
21	Forward alarm speed	rpm	Related to the motor	0~10000	○	All the modes	5-4-11
22	Reverse alarm speed	rpm	Related to the motor	0~10000	○	All the modes	5-4-11
23	T-REF function distribution 0: torque command input 1: the necessary condition of external torque limit input, compare to P3-28/P3-29, min value is effective 2: torque feedforward	—	0	0, 1, 2	○	All the modes	5-4-7/ 5-7-2
24	Rated torque corresponding to the analog value	0.01V	1000	150~3000	○	All the modes	5-7-2
25	Analog voltage torque filter	0.01ms	0	0~10000	√	All the modes	5-7-2
26	Torque command input dead area voltage	0.01V	0	0~100	√	All the modes	5-7-2
28	Internal forward torque	%	300	0~300	√	All the modes	5-4-7
29	Internal reverse torque	%	300	0~300	√	All the modes	5-5-7
30	External forward torque	%	300	0~300	√	2,3,4,6,7	5-4-7
31	External reverse torque	%	300	0~300	√	2,3,4,6,7	5-4-7
32	Brake torque	1%	100	0~300	√	All the modes	5-2-3
33	Preset torque 1	%	0	-300~300	√	1, 2	5-8-2
37	Gravity compensation	%	0			All the modes	
38	Gravity compensation coefficient	%	100			All the modes	

P4: internal position parameters (reserved)

P4-XX	Name	Unit	Default value	Range	Effective	Suitable mode	Chapter
0. xxx□	Pass Z phase signal times after leaving the limit switch(stop when n+1 Z	-	2	0~F	○	5, 6	5-4-7

	phase signal arrived)						
0. xx□x	Find origin function 0: OFF 1: ON	-	0	0~1	○	5, 6	5-4-7
01	Hit proximity switch speed	0.1rpm	600	0~50000	○	5, 6	5-4-7
02	Leaving proximity switch speed	0.1rpm	100	0~50000	○	5, 6	5-4-7
03	Internal position mode	-	n.0000		○	5, 6	5-4-2
04	Effective segment number	-	1	1~35	○	5, 6	5-4-3
10	First segment pulse (low byte)	1 pulse	0	-9999~9999	○	5, 6	5-4-3
11	First segment pulse (high byte)	10000 pulse	0	-32767~327 67	○	5, 6	5-4-3
12	First segment speed	0.1rpm	0	0~10000	○	5, 6	5-4-3
13	First segment acceleration time	1ms	0	0~65535	○	5, 6	5-4-3
14	First segment deceleration time	1ms	0	0~65535	○	5, 6	5-4-3
15	Reserved						
16	Adjustment time	1ms	0	0~65535	○	5, 6	5-4-3
P4-17~P4-23 are internal position segment 2 parameters, the following total 35 segments.							
Note: (1) setting pulse number = pulse numbers (high byte)×10000+pulse number(low byte) (2) total 35 segments. Segment 1~12 parameters can be set through operate panel, segment 13~35 can write in parameters through communication (RS232 or RS485).							

P5: signal parameter setting

P5-	Name	Unit	Default	Range	Effective	Suitable mode	Chapter
00	Positioning finished width /COIN	Command pulse	7	0~ 65535	○	6	5-3-6
01	Positioning finished checking mode 0: offset absolute value below P5-00, output COIN signal 1: offset below P5-00 after command finished, output COIN signal 2: command finished, motor speed below P5-03 and offset absolute value below P5-00, output COIN signal 3: command finished, offset absolute value below P5-00, output COIN signal. If COIN keeps the time P5-02, output COIN-HOLD signal.	-	0	0~3	○	6	5-3-6
02	Positioning finished hold time	ms	0	0~ 65535	○	6	5-3-6
03	Rotation checking speed	rpm	50	1~10000	○	All the modes	5-11-3

04	Same speed checking speed	rpm	50	1~10000	○	3, 4, 7	5-4-6
05	Reach checking speed	rpm	1000	0~10000	○	3, 4, 7	5-4-10
06	Positioning near output width	Command unit	50	0~65535	○	6	5-3-7
07	Servo OFF delay time	ms	0	0~65535	○	All the modes	5-2-5
08	Brake command output speed	rpm	30	0~10000	○	All the modes	5-2-5
09	Brake command waiting time	ms	500	0~65535	○	All the modes	5-2-5
10	User-defined output 1 trigger condition	-	0	0~FFFF	○	All the modes	5-11-7
11	User-defined output 1 trigger condition comparison value	Related to the trigger condition	0	-9999~9999	○	All the modes	5-11-7
12	0: P5-10 \geq P5-11, output SOx 1: P5-10<P5-11, output SOx 2: P5-10 absolute value \geq P5-11, output SOx 3: P5-10 absolute value <P5-11, output SOx	-	0	0~3	○	All the modes	5-11-7
13	User-defined output 1 hysteresis loop	Related to the trigger condition	0	0~65535	○	All the modes	5-11-7
14	User-defined output 2 trigger condition	-	0	0~FFFF	○	All the modes	5-11-7
15	User-defined output 2 trigger condition comparison value	Related to the trigger condition	0	-9999~9999	○	All the modes	5-11-7
16	0: P5-14 \geq P5-15, output SOx 1: P5-14 \leq P5-15, SOx output 2: P5-14 absolute value \geq P5-15, output SOx 3: P5-14 absolute value <P5-15, output SOx	-	0	0~3	○	All the modes	5-11-7
17	User-defined output 2 hysteresis loop	Related to the trigger condition	0	0~65535	○	All the modes	5-11-7
18	IO filter time	ms	0	0~10000	○	All the modes	5-11-8
19	Z phase signal pulse width	ms	2	2~20	√	All the modes	5-11-5
20	/S-ON servo signal 0000: signal is always invalid 0001: input positive signal from SI1 0002: input positive signal from SI2 0003: input positive signal from SI3 0004: input positive signal from SI4	—	n.0001	n.0000~n.0015	√	All the modes	5-2-1

	0010: signal is always valid 0011: input negative signal from SI1 0012: input negative signal from SI2 0013: input negative signal from SI3 0014: input negative signal from SI4						
21	/P-CON proportion action command Ditto	—	n.0000	n.0000~n.0015	√	All the modes	5-4-4
22	/P-OT forward drive ban ditto	—	n.0003	n.0000~n.0015	√	All the modes	5-2-4
23	/N-OT reverse drive ban ditto	—	n.0004	n.0000~n.0015	√	All the modes	5-2-4
24	/ALM-RST alarm clean ditto	—	n.0002	n.0000~n.0015	√	All the modes	5-11-1
25	/P-CL forward side external torque limit ditto	—	n.0000	n.0000~n.0015	√	All the modes	5-4-7
26	/N-CL reverse side external torque limit ditto	—	n.0000	n.0000~n.0015	√	All the modes	5-4-7
27	/SPD-D internal speed direction choice ditto	—	n.0000	n.0000~n.0015	√	1,2,3,4	5-5-3
28	/SPD-A internal setting speed choice ditto	—	n.0000	n.0000~n.0015	√	3,6	5-5-3
29	/SPD-B internal setting speed choice ditto	—	n.0000	n.0000~n.0015	√	3,6	5-5-3
30	/C-SEL control mode choice ditto	—	n.0000	n.0000~n.0015	√	All the modes	5-10
31	/ZCLAMP zero clamp ditto	—	n.0000	n.0000~n.0015	√	3,4,7	5-4-5
32	/INHIBIT command pulse ban ditto		n.0000	n.0000~n.0015	√	6	5-3-8
33	/G-SEL gain switching ditto	—	n.0000	n.0000~n.0015	√	All the modes	6-2-1
34	/CLR pulse offset clean ditto	—	n.0000	n.0000~n.0015	√	6	5-3-5
36	/I-SEL inertia ratio switching		n.0000	n.0000~n.0015	√	All the modes	
37	/COIN_HD positioning finished hold 0000: not output to the terminal 0001: output positive signal from SO1 0002: output positive signal from SO2 0003: output positive		n.0000	n.0000~n.0013	√	6	5-3-6

	signal from SO3 0011: output negative signal from SO1 0012: output negative signal from SO2 0013: output negative signal from SO3						
38	/COIN positioning finished ditto	—	n.0001	n.0000~ n.0013	√	6	5-3-6
39	/V-CMP same speed checking ditto	—	n.0000	n.0000~ n.0013	√	3,4,7	5-5-6
40	/TGON rotation checking ditto	—	n.0000	n.0000~ n.0013	√	All the modes	5-11-3
41	/S-RDY ready ditto	—	n.0000	n.0000~ n.0013	√	All the modes	5-11-4
42	/CLT torque limit ditto	—	n.0000	n.0000~ n.0013	√	3,4,6,7	5-4-7
43	/VLT speed limit checking ditto	—	n.0000	n.0000~ n.0013	√	1,2,6	5-7-5
44	/BK brake lock Ditto(BK signal output from SO1, P5-44=n.0001. BK signal output from SO2, P5-44=n.0002.)	—	n.0000	n.0000~ n.0013	√	All the modes	5-2-5
45	/WARN warning ditto	—	n.0000	n.0000~ n.0013	√	All the modes	5-11-2
46	/NEAR near ditto	—	n.0000	n.0000~ n.0013	√	5, 6	5-3-7
47	/ALM alarm ditto	—	n.0002	n.0000~ n.0013	√	All the modes	5-11-1
48	/Z phase encoder signal	—	n.0000	n.0000~ n.0013	√	All the modes	5-11-1
51	/V-RDY speed arrived	—	n.0000	n.0000~ n.0013	√	3, 4, 7	5-5-10
52	/user-defined output 1 terminal setting	—	n.0000	n.0000~ n.0013	○	All the modes	5-11-7
53	/user-defined output 2 terminal setting	—	n.0000	n.0000~ n.0013	○	All the modes	5-11-7
57	/PREFA internal position segment 1 position option		※ 1	※ 3	√	5	5-4-2
58	/PREFB internal position segment 2 position option		※ 1	※ 3	√	5	5-4-2
59	/PREFC internal position segment 3 position option		※ 1	※ 3	√	5	5-4-2

※1 servo drives input terminal default value: refer to chapter 5-12-2.

※2 servo drive output terminal default value: refer to chapter 5-12-4.

※3 servo drive input terminal distribution: refer to chapter 5-12-1.

※4 servo drive output terminal distribution: refer to chapter 5-12-3.

P6: signal parameters (reserved)

P6-XX	Name	Unit	Default value	Range	Effective	Suitable mode	Chapter
00~04	-	-	-	-	-	-	-

P7: communication parameters

P7-XX	Name	Unit	Default value	Range	Effective	Chapter		
00	RS485 station no.	—	1	1~255	○	3-1-5		
01	RS485 parameters	n.xx□□	Baud rate	06	00~10 00: 300 01: 600 02: 1200 03: 2400 04: 4800 05: 9600 06: 19200 07: 38400 08: 57600 09: 115200	0A: 192000 0B: 256000 0C: 288000 0D: 384000 0E: 512000 0F: 576000 10: 768000 11: 1M 12: 2M 13: 3M 14: 4M 15: 5M 16: 6M	○	3-1-5
		n.x□xx	Stop bit	2	0: 2 bits 2: 1 bit	○	3-1-5	
		n.□xxx	Parity bit	2	0~2 0: no parity 1: odd 2: even	○	3-1-5	
		Note: data bit cannot set, it is 8 bits.						
02	RS485 communication protocol	—	1	1: Modbus Rtu protocol 2: Xnet fieldbus protocol	○	3-1-5		
10	RS232 station no.	—	1	1~255	○	3-1-5		
11	RS232 parameters	—	2206	Parameter setting same to P7-01	○	3-1-5		

Appendix 2 UX-XX monitoring parameters

U0-XX:

Monitor code	Contents	Unit
U0-00	Servo motor speed	Rpm
U0-01	Input speed command	Rpm
U0-02	Torque command	% rated
U0-03	Mechanical angle	1 °
U0-04	Electric angle	1 °
U0-05	Bus voltage	V
U0-06	IPM temperature	0.1°C
U0-07	Torque feedback	% rated
U0-08	Pulse deviation value	(0000~9999)*1
U0-09		(0000~65535)*10000
		Command pulse

U0-10	Encoder feedback	(0000~9999)*1	Encoder pulse
U0-11		(0000~65535)*10000	
U0-12	Input command pulse numbers	(0000~9999)*1	Command pulse
U0-13		(0000~65535)*10000	
U0-14	Position feedback	(0000~9999)*1	Command pulse
U0-15		(0000~65535)*10000	
U0-16	Encoder accumulated position	(0000~9999)*1	Encoder pulse
U0-17		(0000~65535)*10000	
U0-18	Torque current		0.01A
U0-19	Analog input V-REF value		0.01V
U0-20	Analog input T-REF value		0.01V
U0-21	Input signal state 1		
U0-22	Input signal state 2		
U0-23	Output signal state 1		
U0-24	Output signal state 2		
U0-25	Input pulse frequency	(0000~9999)*1	Hz
U0-26		(0000~9999)*10000	
U0-41	Instant output power		1W
U0-42	Average output power		1W
U0-43	Instant heat power		1W
U0-44	Average heat power		1W
U0-49	Position feedforward		1 command unit
U0-50	Speed feedforward		rpm
U0-51	Torque feedforward		% rated
U0-52	Instant bus capacitance power		1W
U0-53	Average bus capacitance power		1W
U0-55	Instant regenerative brake discharge power		1W
U0-56	Average regenerative brake discharge power		1W
U0-57	Absolute encoder present position feedback	(0000~9999)*1	Encoder pulse
U0-58		(0000~65535)*10000	

U1-XX:

Monitor code	Contents	Unit
U1-00	Present alarm code	
U1-01	Present warn code	
U1-02	U phase current when alarming	0.01A
U1-03	V phase current when alarming	0.01A
U1-04	Bus voltage when alarming	V
U1-05	IGBT temperature when alarming	0.1°C
U1-06	Torque current when alarming	0.01A
U1-07	Excitation current when alarming	A
U1-08	Position deviation when alarming	Command pulse
U1-09	Speed value when alarming	rpm
U1-10	Second(low 16 bits) when alarming, count from the first time of power on	s
U1-11	Second(high 16 bits) when alarming, count from the first time of power on	s

U1-12	Running error numbers, count from power on this time	
U1-13	Running warning numbers, count from power on this time	
U1-14	History alarm numbers	
U1-15	History warn numbers	
U1-16	The second time alarm code recently	
U1-17	The third time alarm code recently	
U1-18	The fourth time alarm code recently	
U1-19	The fifth time alarm code recently	
U1-20	The sixth time alarm code recently	
U1-21	The second time warn code recently	
U1-22	The third time warn code recently	
U1-23	The fourth time warn code recently	
U1-24	The fifth time warn code recently	
U1-25	The sixth time warn code recently	

U2-XX:

Monitor code	Contents	Unit
U2-00	Power on times	
U2-01	Series	
U2-02	Model (low 16 bits)	
U2-03	Model (high 16 bits)	
U2-04	Out of factory date: year	
U2-05	Out of factory date: month	
U2-06	Out of factory date: day	
U2-07	Firmware version	
U2-08	Hardware version	
U2-09	Total running time (from power on at the first time)	Hour
U2-10	Total running time (from power on at the first time)	Minute
U2-11	Total running time (from power on at the first time)	Second
U2-12	This time running time (from power on this time)	Hour
U2-13	This time running time (from power on this time)	Minute
U2-14	This time running time (from power on this time)	Second
U2-15	Average output power (from the first time enable, average power in enable process)	1W
U2-16	Average heat power (from the first time enable, average power in enable process)	1W
U2-17	Average bus capacitance filter power (from the first time power on, average power after power on)	1W
U2-18	Motor accumulated (0000~9999)*1	Cycle
U2-19	cycles (0000~9999)*10000	Cycle
U2-20	Device serial no.: lower 16 bits	
U2-21	Device serial no.: high 16 bits	
U2-22	Firmware generation date: year	
U2-23	Firmware generation date: month/day	
U2-24	Firmware generation time: hour/minute	

Appendix 3 FX-XX auxiliary function

Function code	Explanation	Effective	Reference chapter
F0-00	Clear the alarm	○	4-4
F0-01	Restore the factory setting	○	4-4
F0-02	Clear the position deviation	○	4-4
F1-00	Jog	○	4-4
F1-01	Test run	○	4-4
F1-02	Current sampling zero correction	○	4-4
F1-03	Vref zero correction	○	4-4
F1-04	Tref zero correction	○	4-4
F1-05	Software enable	○	4-4

Appendix 4 Modbus address

Modbus address

Parameter	Modbus address		Parameter	Modbus address	
	Hex	Decimal		Hex	Decimal
P0-00	0x0000	0	P0-17	0x0011	17
P0-01	0x0001	1	P0-18	0x0012	18
P0-02	0x0002	2	P0-19	0x0013	19
P0-03	0x0003	3	P0-20	0x0014	20
P0-04	0x0004	4	P0-21	0x0015	21
P0-05	0x0005	5	P0-22	0x0016	22
P0-06	0x0006	6	P0-23	0x0017	23
P0-07	0x0007	7	P0-24	0x0018	24
P0-08	0x0008	8	P0-25	0x0019	25
P0-09	0x0009	9	P0-26	0x001A	26
P0-10	0x000A	10	P0-27	0x001B	27
P0-11	0x000B	11	P0-28	0x001C	28
P0-12	0x000C	12	P0-29	0x001D	29
P0-13	0x000D	13	P0-30	0x001E	30
P0-14	0x000E	14	P0-31	0x001F	31
P0-15	0x000F	15	P0-32	0x0020	32
P0-16	0x0010	16	P0-33	0x0021	33

Parameter	Modbus address		Modbus address	Modbus address	
	Hex	Decimal		Hex	Decimal
P1-00	0x0100	256	P1-15	0x010F	271
P1-01	0x0101	257	P1-16	0x0110	272
P1-02	0x0102	258	P1-17	0x0111	273
P1-03	0x0103	259	P1-18	0x0112	274
P1-04	0x0104	260	P1-19	0x0113	275
P1-05	0x0105	261	P1-20	0x0114	276
P1-06	0x0106	262	P1-21	0x0115	277
P1-07	0x0107	263	P1-22	0x0116	278
P1-08	0x0108	264	P1-23	0x0117	279
P1-09	0x0109	265	P1-24	0x0118	280
P1-10	0x010A	266	P1-25	0x0119	281

P1-11	0x010B	267	P1-26	0x011A	282
P1-12	0x010C	268	P1-27	0x011B	283
P1-13	0x010D	269	P1-28	0x011C	284
P1-14	0x010E	270			

Parameter	Modbus address		Modbus address	Modbus address	
	Hex	Decimal		Hex	Decimal
P2-00	0x0200	512	P2-15	0x20F	527
P2-01	0x0201	513	P2-16	0x210	528

Parameter	Modbus address		Modbus address	Modbus address	
	Hex	Decimal		Hex	Decimal
P3-00	0x0300	768	P3-19	0x0313	787
P3-01	0x0301	769	P3-20	0x0314	788
P3-02	0x0302	770	P3-21	0x0315	789
P3-03	0x0303	771	P3-22	0x0316	790
P3-04	0x0304	772	P3-23	0x0317	791
P3-05	0x0305	773	P3-24	0x0318	792
P3-06	0x0306	774	P3-25	0x0319	793
P3-07	0x0307	775	P3-26	0x031A	794
P3-08	0x0308	776	P3-27	0x031B	795
P3-09	0x0309	777	P3-28	0x031C	796
P3-10	0x030A	778	P3-29	0x031D	797
P3-11	0x030B	779	P3-30	0x031E	798
P3-12	0x030C	780	P3-31	0x031F	799
P3-13	0x030D	781	P3-32	0x0320	800
P3-14	0x030E	782	P3-33	0x0321	801
P3-15	0x030F	783	P3-34	0x0322	802
P3-16	0x0310	784	P3-35	0x0323	803
P3-17	0x0311	785	P3-36	0x0324	804
P3-18	0x0312	786			

Parameter	Modbus address		Modbus address	Modbus address	
	Hex	Decimal		Hex	Decimal
P4-00	0x0400	1024	P4-15	0x040F	1039
P4-01	0x0401	1025	P4-16	0x0410	1040

Parameter	Modbus address		Parameter	Modbus address	
	Hex	Decimal		Hex	Decimal
P5-00	0x0500	1280	P5-27	0x051B	1307
P5-01	0x0501	1281	P5-28	0x051C	1308
P5-02	0x0502	1282	P5-29	0x051D	1309
P5-03	0x0503	1283	P5-30	0x051E	1310
P5-04	0x0504	1284	P5-31	0x051F	1311
P5-05	0x0505	1285	P5-32	0x0520	1312
P5-06	0x0506	1286	P5-33	0x0521	1313
P5-07	0x0507	1287	P5-34	0x0522	1314
P5-08	0x0508	1288	P5-35	0x0523	1315
P5-09	0x0509	1289	P5-36	0x0524	1316
P5-10	0x050A	1290	P5-37	0x0525	1317
P5-11	0x050B	1291	P5-38	0x0526	1318
P5-12	0x050C	1292	P5-39	0x0527	1319
P5-13	0x050D	1293	P5-40	0x0528	1320
P5-14	0x050E	1294	P5-41	0x0529	1321
P5-15	0x050F	1295	P5-42	0x052A	1322

P5-16	0x0510	1296	P5-43	0x052B	1323
P5-17	0x0511	1297	P5-44	0x052C	1324
P5-18	0x0512	1298	P5-45	0x052D	1325
P5-19	0x0513	1299	P5-46	0x052E	1326
P5-20	0x0514	1300	P5-47	0x052F	1327
P5-21	0x0515	1301	P5-48	0x0530	1328
P5-22	0x0516	1302	P5-49	0x0531	1329
P5-23	0x0517	1303	P5-50	0x0532	1330
P5-24	0x0518	1304	P5-51	0x0533	1331
P5-25	0x0519	1305	P5-52	0x0534	1332
P5-26	0x051A	1306	P5-53	0x0535	1333

Parameter	Modbus address		Parameter	Modbus address	
	Hex	Decimal		Hex	Decimal
P6-00	0x0600	1536	P6-10	0x060A	1546
P6-01	0x0601	1537	P6-11	0x060B	1547

Parameter	Modbus address		Parameter	Modbus address	
	Hex	Decimal		Hex	Decimal
P7-00	0x0700	1792	P7-10	0x070A	1802
P7-01	0x0701	1793			

Monitor parameter Modbus address

Parameter	Modbus address		Parameter	Modbus address	
	Hex	Decimal		Hex	Decimal
U0-00	0x1000	4096	U0-28	0x101C	4124
U0-01	0x1001	4097	U0-29	0x101D	4125
U0-02	0x1002	4098	U0-30	0x101E	4126
U0-03	0x1003	4099	U0-31	0x101F	4127
U0-04	0x1004	4100	U0-32	0x1020	4128
U0-05	0x1005	4101	U0-33	0x1021	4129
U0-06	0x1006	4102	U0-34	0x1022	4130
U0-07	0x1007	4103	U0-35	0x1023	4131
U0-08	0x1008	4104	U0-36	0x1024	4132
U0-09	0x1009	4105	U0-37	0x1025	4133
U0-10	0x100A	4106	U0-38	0x1026	4134
U0-11	0x100B	4107	U0-39	0x1027	4135
U0-12	0x100C	4108	U0-40	0x1028	4136
U0-13	0x100D	4109	U0-41	0x1029	4137
U0-14	0x100E	4110	U0-42	0x102A	4138
U0-15	0x100F	4111	U0-43	0x102B	4139
U0-16	0x1010	4112	U0-44	0x102C	4140
U0-17	0x1011	4113	U0-45	0x102D	4141
U0-18	0x1012	4114	U0-46	0x102E	4142
U0-19	0x1013	4115	U0-47	0x102F	4143
U0-20	0x1014	4116	U0-48	0x1030	4144
U0-21	0x1015	4117	U0-49	0x1031	4145
U0-22	0x1016	4118	U0-50	0x1032	4146
U0-23	0x1017	4119	U0-51	0x1033	4147
U0-24	0x1018	4120	U0-52	0x1034	4148
U0-25	0x1019	4121	U0-53	0x1035	4149
U0-26	0x101A	4122	U0-57	0x1039	4153
U0-27	0x101B	4123	U0-58	0x1040	4154

Parameter	Modbus address		Parameter	Modbus address	
	Hex	Decimal		Hex	Decimal
U1-00	0x1100	4352	U2-00	0x1200	4608
U1-01	0x1101	4353	U2-01	0x1201	4609
U1-02	0x1102	4354	U2-02	0x1202	4610
U1-03	0x1103	4355	U2-03	0x1203	4611
U1-04	0x1104	4356	U2-04	0x1204	4612
U1-05	0x1105	4357	U2-05	0x1205	4613
U1-06	0x1106	4358	U2-06	0x1206	4614
U1-07	0x1107	4359	U2-07	0x1207	4615
U1-08	0x1108	4360	U2-08	0x1208	4616
U1-09	0x1109	4361	U2-09	0x1209	4617
U1-10	0x110A	4362	U2-10	0x120A	4618
U1-11	0x110B	4363	U2-11	0x120B	4619
U1-12	0x110C	4364	U2-12	0x120C	4620
U1-13	0x110D	4365	U2-13	0x120D	4621
U1-14	0x110E	4366	U2-14	0x120E	4622
U1-15	0x110F	4367	U2-15	0x120F	4623
U1-16	0x1110	4368	U2-16	0x1210	4624
U1-17	0x1111	4369	U2-17	0x1211	4625
U1-18	0x1112	4370	U2-18	0x1212	4626
U1-19	0x1113	4371	U2-19	0x1213	4627
U1-20	0x1114	4372	U2-20	0x1214	4628
U1-21	0x1115	4373			
U1-22	0x1116	4374			
U1-23	0x1117	4375			
U1-24	0x1118	4376			
U1-25	0x1119	4377			

Parameter	Modbus address		Parameter	Modbus address	
	Hex	Decimal		Hex	Decimal
F0-00	0x2000	8192	F1-00	0x2100	8448
F0-01	0x2001	8193	F1-01	0x2101	8449
F0-02	0x2002	8194	F1-02	0x2102	8450
F2-09	0x2209	8713	F1-03	0x2103	8451
			F1-04	0x2104	8452
			F1-05	0x2105	8453

Appendix 5 General debug steps

1. the motor without load, test run

(1) connect the cable, please note that U, V, W, PE must connect one to one, cannot crossed.

(2) open loop test run: check the power supply cable and encoder feedback, make sure the connection is normal. Do as the below steps to run the motor forward or reverse, if the motor shaft vibrate or alarm, please cut off the power at once, check the wiring.

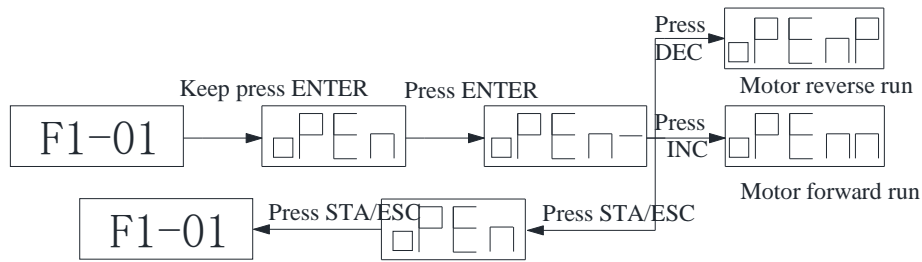

(3) jog run: enter parameter F1-00. Press ENTER to enable the motor. Press INC to jog forward run the motor, press DEC to jog reverse run the motor. Press STATUS/ESC to end the enable and exit the jog state.

4 states in jog run state:

State	Panel display	State	Panel display
Idle		Forward run	
Enable		Reverse run	

2. Connect the motor with the load, test again

(1) monitor the motor head running direction, if it is contrary to the actual direction, please cut off the servo drive, set P0-05 to 1, then power on the servo drive again.

(2) monitor the stability and response when running, adjust the servo controlling parameter.

3. Debug with the PLC program.

Appendix 6 Application

Mode 6: pulse command position mode

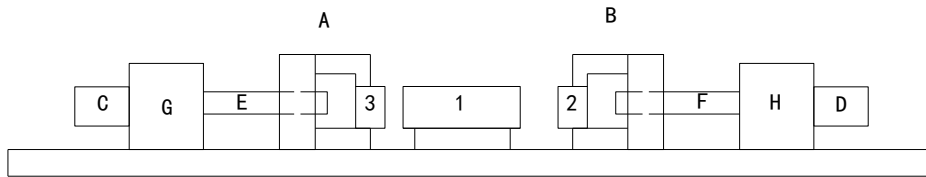

Equipment introduction:

This is a welder. Workpiece 1, 2, 3 are the object to be operated. 2 and 3 is fixed on B and A individually. A and B can whole move and be pushed by ball screw E and F. The screw pitch is 5mm. C and D is servo motor. G and H is reducer. The deceleration ratio is 40.

It needs to adjust the machine with standard dimension workpiece and find the origin of A and B.

Workpiece 1 lies on the worktable and moves left and right. Its dimension is positive tolerance, cannot shorter than standard workpiece. The process to put the workpiece is random. It requires that the left and right soldering is symmetrical.

A and B move toward 1 with 3 and 2 at the same speed. Whatever the position of 1, 2 or 3 will touch 1 at first and push 1 to another side until 2 and 3 all touch 1. The result is the motor torque will increase. At this time, 1 will be at the symmetrical position.

A and B will return to the origin position after soldering is finished.

Analysis

1. Make sure the work mode: 6
2. It needs to judge whether 2 and 3 touch 1 when finding the symmetrical point. The sign is servo

output torque will increase. It needs to use torque limit (P4-02, P4-03) and torque limit output signal /CLT.

- As the dimension of workpiece is larger than standard, offset pulse will remain in servo when the symmetrical point is found. /CLR signal can clear the pulse. The servo motor running distance is different from PLC pulse number. If it needs to know the actual distance, servo encoder feedback /A+, /A-, /B+, /B- and AB phase count are needed.
- The motion direction of A and B.

Signal and terminal

/COIN positioning finished signal: SO1
 /CLT torque up to upper limit output: SO2
 /CLR pulse offset clear input: SI1
 Encoder feedback signal /A+, /A-, /B+, /B-

Calculate the electronic gear ratio

Step	Explanation	Ball screw
	<p style="text-align: center;">1 rotation = $\frac{P}{\text{Command unit}}$</p>	
1	Confirm the mechanical specification	Ball screw pitch: 5mm Reduction ratio: 40/1
2	Confirm the encoder pulse number	2500P/R
3	Decide the command unit	1 command unit: 0.001mm
4	Calculate the motion value of load shaft rotate 1 circle	5mm/0.001mm = 5000
5	Calculate the electronic gear ratio	$\frac{B}{A} = \frac{2500 \times 4}{5000} \times \frac{40}{1} = \frac{80}{1}$
6	Set the user parameters	P0-13=80 P0-14=1

Parameter setting

Running mode: P0-01=6
 Pulse command state: P0-10=2
 Electronic gear ratio: P0-11=0 P0-12=0 P0-13=80 P0-14=1
 Forward torque limit: P3-28=150
 Reverse torque limit: P3-29=150
 Positioning finished width: P5-00=7
 /S-ON: P5-20=0010
 /CLR: P5-34=0001
 /COIN: P5-38=0001
 /CLT: P5-42=0002

Debug

1. Initial debug

- Connect the cables correctly. Connect U, V, W, PE one-to-one, don't cross them.
- open-loop test-running: power on, set F1-01=1, check if the motor can work normally. If yes, enter F1-00. If not, check the cables.
- Jog test-running: enter F1-00. Press ENTER to enable the motor. Press INC for forward jog, press DEC for reverse jog. Press STATUS/ESC to quit the jog running.

4 states when jogging:

State	Panel display	State	Panel display
Idle		Forward run	

Enable		Reverse run	
--------	--	-------------	--

(d) Current check offset auto-adjustment
 Enter F1-02, it shows rEF.
 Press ENTER, it shows rEF and flickers.
 After 5s the auto-adjustment finished, it shows donE.
 Press STATUS/ESC to exit.

2. Debug the motor with machine

- (a) Check the motor rotation direction, if it is reverse from the actual needs, set servo force OFF. Then set P0-05 to 1, re-power on the servo.
- (b) Check the servo stability and response, adjust the servo gain.

3. Debug with PLC program.

Appendix 7 Compatible table of servo and motor

Incremental 2500ppr encoder servo system

Servo drive	Motor model	Motor code	Voltage level
DS3-20P2-PQA	MS-40ST-M00330 □□-20P1	1002	Single/3-phase 220V
DS3-20P2-PQA DS3E/DS3L-20P2-PFA	MS-60ST-M00630 □□-20P2	1003	
DS3-20P4-PQA DS3E/DS3L-20P4-PFA	MS-60ST-M01330 □□-20P4	1004	
DS3E/DS3L-20P4-PFA	MS-60ST-M01330 □□ S-20P4(short body)	F004	
DS3E/DS3L-20P7-PFA	MS-80ST-M02430 □□ S-20P7	F011	
DS3-20P7-PQA DS3E/DS3L-20P7-PFA	MS-80ST-M02430 □□-20P7	1011	
	MS-80ST-M03520 □□-20P7	0012	
	MS-90ST-M02430 □□-20P7	0021	
DS3-21P5-PQA DS3E/DS3L-21P5-PFA	MS-110ST-M04030 □□-21P2	0031	3-phase 220V
	MS-110ST-M05030 □□-21P5	0032	
	MS-130ST-M04030 □□-21P2	1031	
	MS-130ST-M06025 □□-21P5	1042(0042)	
	MS-130ST-M10010 □□-21P0	1040	
MS-130ST-M10015 □□-21P5	1044(0044)		
DS3-22P3-PQA DS3E/DS3L-22P3-PFA	MS-130ST-M07725 □□-22P0	0043	
	MS-130ST-M15015 □□-22P3	0046	
DS3E/DS3L-22P6-PFA	MS-130ST-M10025 □□-22P6	0045	
DS3-41P5-PQA DS3E/DS3L-41P5-PFA	MS-110ST-M04030-41P2	0131	
	MS-110ST-M05030-41P5	0132	
	MS-130ST-M06025-41P5	0142	
	MS-130ST-M10015-41P5	2144(0144)	
DS3-43P0-PQA DS3E/DS3L-43P0-PFA	MS-130ST-M07725-42P0	1143	
	MS-130ST-M10030-43P0	1148	
	MS-130ST-M15015-42P3	1146	
	MS-180ST-M19015-43P0	1166(1052/0156)	
DS3-45P5-PQA	MS-180ST-M21520-44P5	0150	

DS3L-45P5-PQA	MS-180ST-M27015-44P3	1161(2151/ 0151)	
	MS-180ST-M35015-45P5	1162(1152/ 0152)	
DS3-47P5-PQA DS3L-47P5-PQA	MS-180ST-M48015-47P5	1163(0153)	
DS3-411P0-PQA	MS-220ST-M70015-411P0	1157	

17-bit absolute encoder servo system

Servo drive	Motor model	Cable type	Encoder type
DS3-20P2-PNA	MS-60ST-T00630B-20P2 MS-60ST-T00630BZ-20P2	Encoder cable: CP-DP-B-02 Power supply cable: CM-P07-02 (note: 02 means the length is 2 meter, the cable length can be customized)	20-bit absolute encoder
DS3-20P4-PNA	MS-60ST-T01330B-20P4 MS-60ST-T01330BZ-20P4		
DS3-20P7-PTA	MS-80ST-T02430B-20P7 MS-80ST-T02430BZ-20P7	Encoder cable: CP-DL-B-02 Power supply cable: CM-L15-02 (note: 02 means the length is 2 meter, the cable length can be customized)	17-bit absolute encoder
DS3-21P5-PTA	MS-110ST-T05030B-21P5		
	MS-110ST-T05030BZ-21P5		
	MS-130ST-T10015B-21P5		
DS3-22P3-PTA	MS-130ST-T10015BZ-21P5		
	MS-130ST-T06025B-21P5		
	MS-130ST-T06025BZ-21P5		
	MS-130ST-T15015B-22P3		
	MS-130ST-T15015BZ-22P3		
	MS-130ST-T07730B-22P4		
	MS-130ST-T07730BZ-22P4		
	MS-130ST-T07730BZ-22P4		

XINJE



WUXI XINJE ELECTRIC CO., LTD.

4th Floor Building 7,Originality Industry
park, Liyuan Development Zone, Wuxi
City, Jiangsu Province
214072

Tel: (510) 85134136

Fax: (510) 85111290

www.xinje.com